

EVEREST 8x6 Domek z tworzywa/Plastic shed

Instrukcja montażu/Assembly instructions

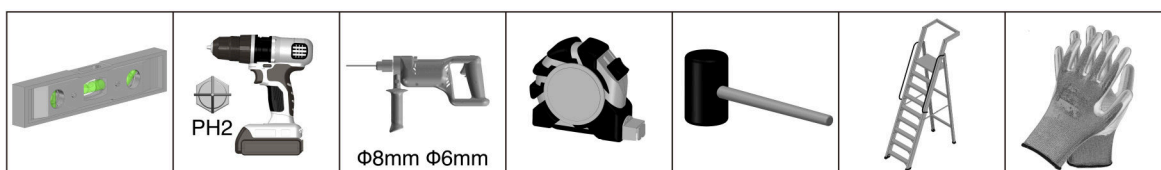

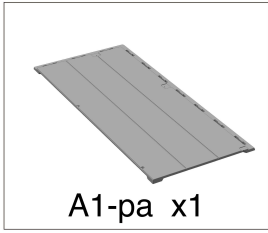
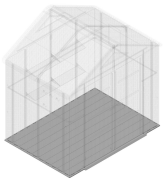

A1-pa x1

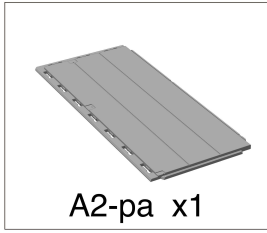

A2-pa x1

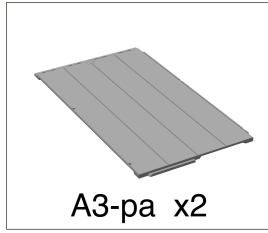

A3-pa x2

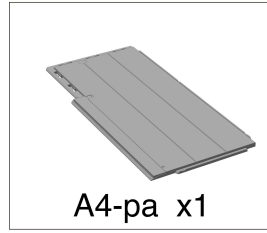

A4-pa x1

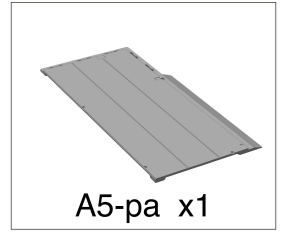

A5-pa x1

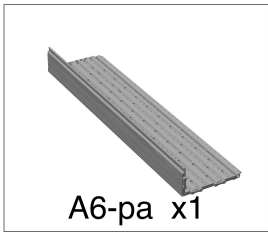
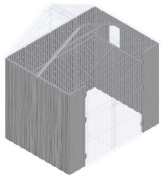

A6-pa x1

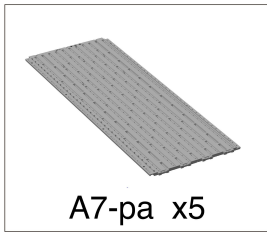

A7-pa x5

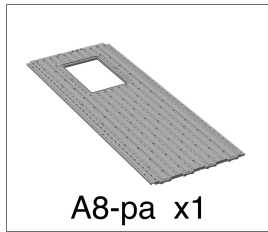

A8-pa x1

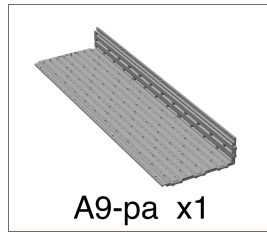

A9-pa x1

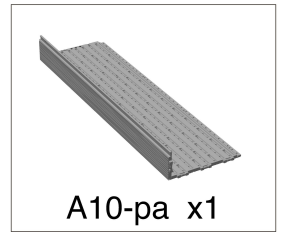

A10-pa x1

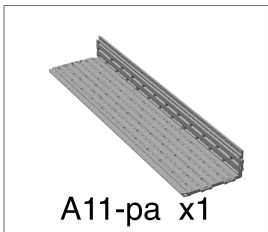

A11-pa x1

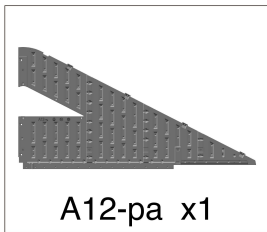

A12-pa x1

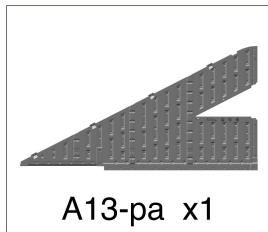

A13-pa x1

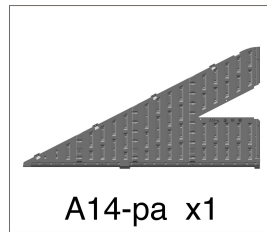

A14-pa x1

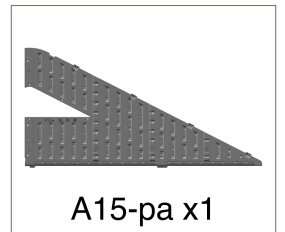

A15-pa x1

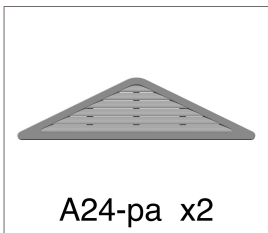

A24-pa x2

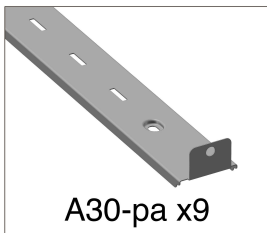

A30-pa x9

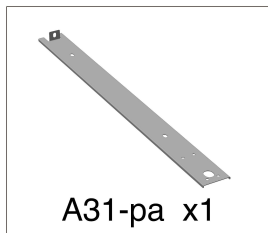

A31-pa x1

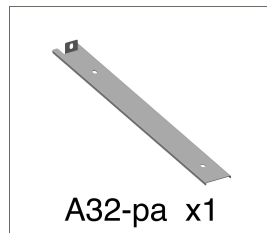

A32-pa x1

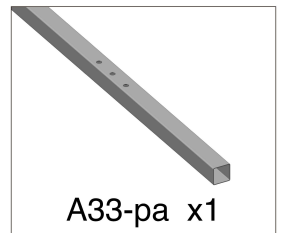

A33-pa x1

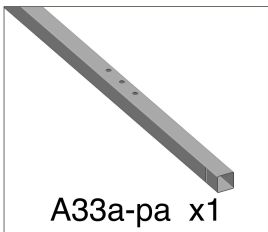

A33a-pa x1

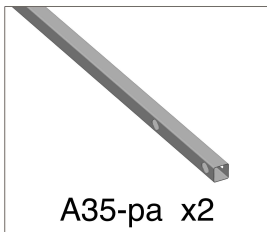

A35-pa x2

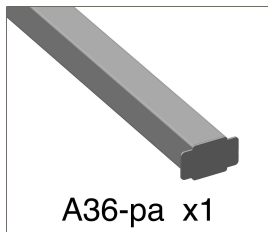

A36-pa x1

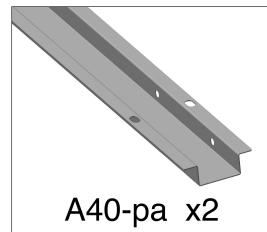

A40-pa x2

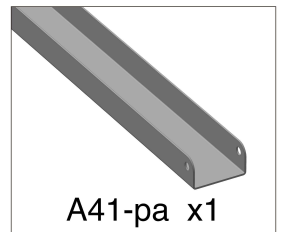

A41-pa x1

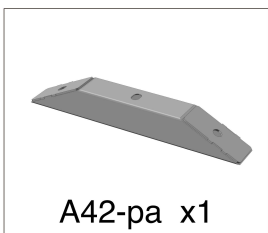

A42-pa x1

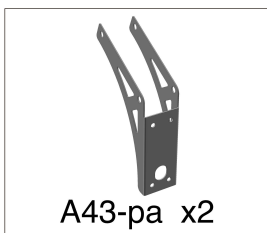

A43-pa x2

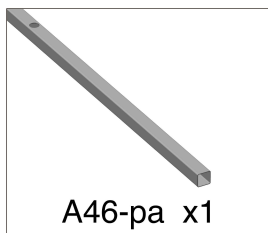

A46-pa x1

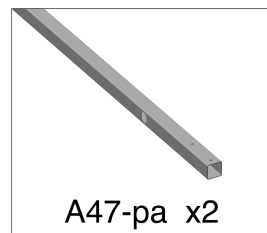

A47-pa x2

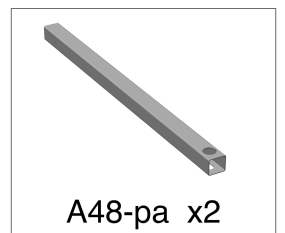

A48-pa x2

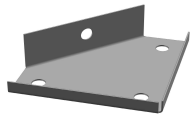

Ab-4 x4

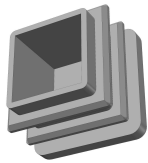

21-pa x2



16-pa x10

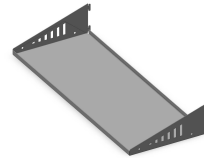

19-pa x2



11-pa x5

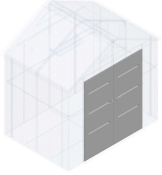

A22-pa x1

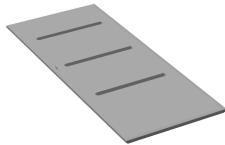

A23-pa x1

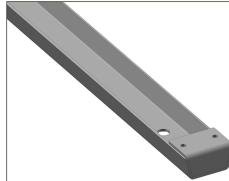

A34-pa x2

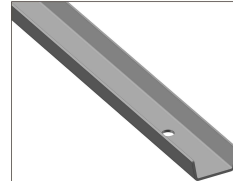

A34a-pa x2

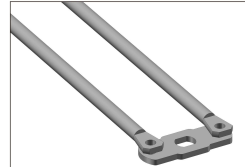

7-pa x1

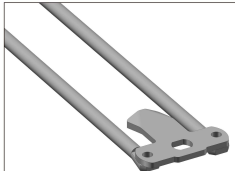

8-pa x1

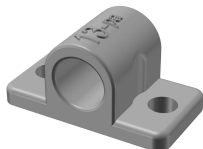

13-pa x2

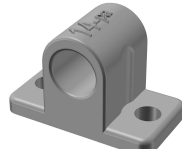

14-pa x2

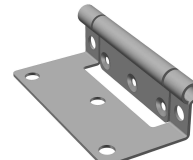

15-pa x6

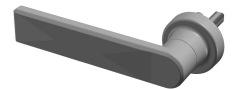

1-pa x1

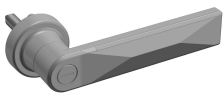

2-pa x1



1.1-pa x4

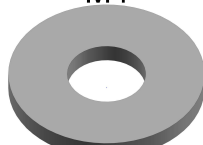

1.2-pa x4

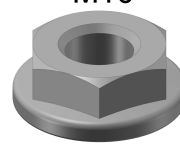

1.3-pa x2

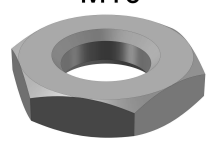

1.4-pa x2

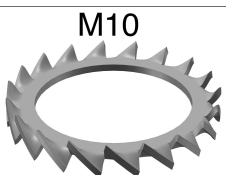

1.5-pa x2

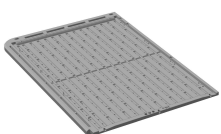
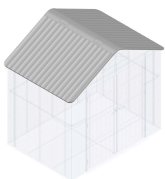

A16-pa x2



A17-pa x2

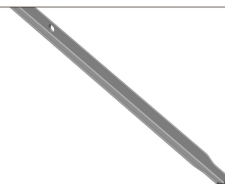

A44-pa x4



A19-pa x1

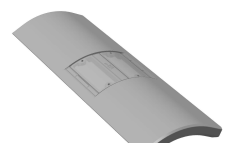

A20-pa x1

M4x10mm

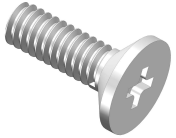

A50-pa x18

ST4x12mm



A51-pa x40

ST4.2x13mm



A52-pa x4

M6x10mm

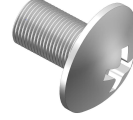

A53-pa x48

M6x18mm



A54-pa x33

M6x25mm



A55-pa x9

M6x40mm

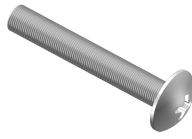

A56-pa x1

ST6x12mm



A57-pa x20

ST6x16mm

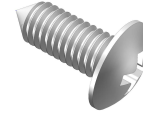

A58-pa x69

ST6x20mm

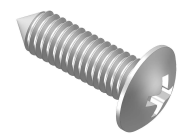

A59-pa x44

ST8x60mm

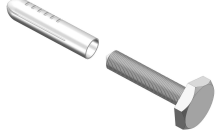

A60-pa x11

M6

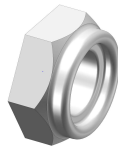

A61-pa x12

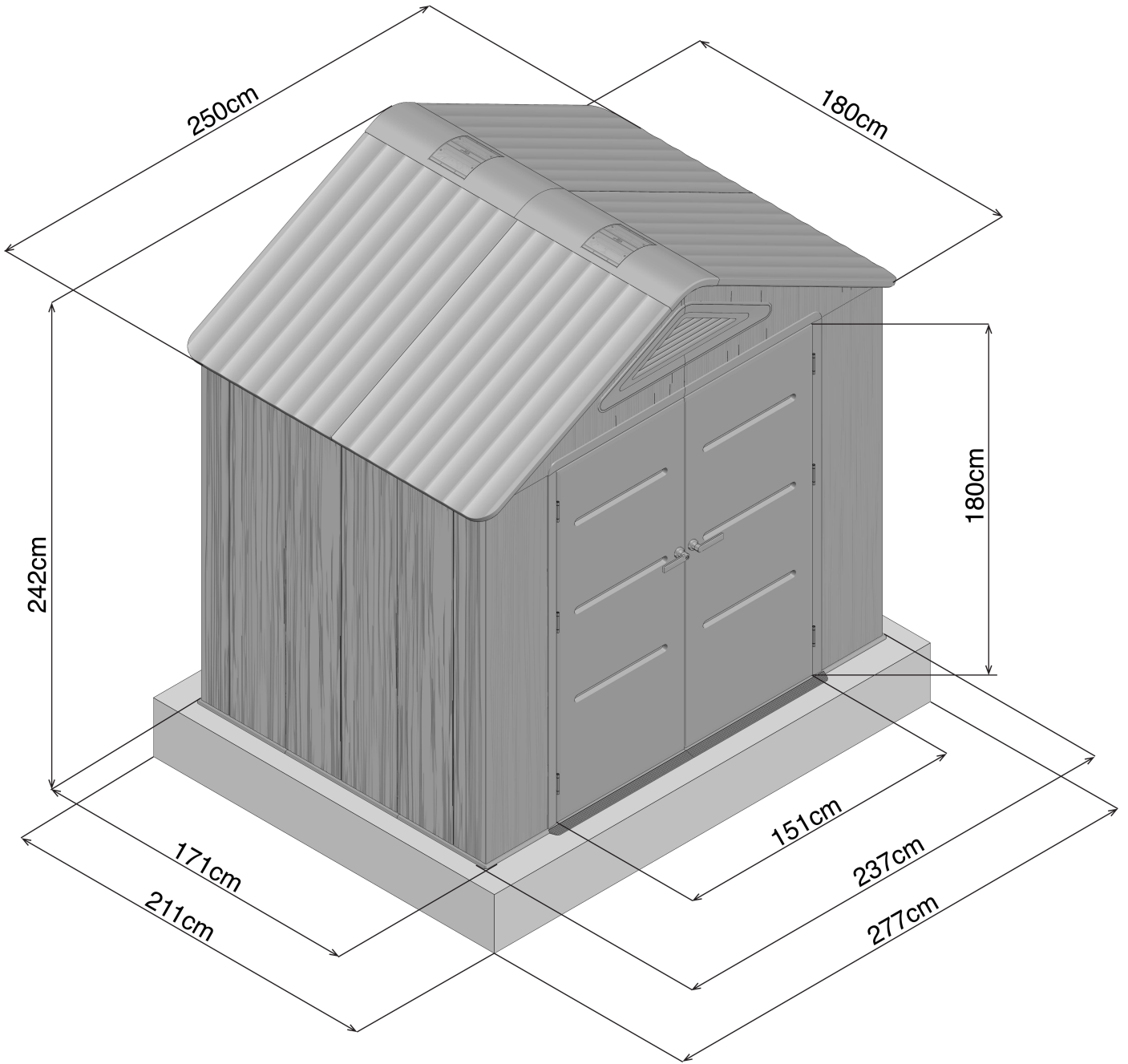

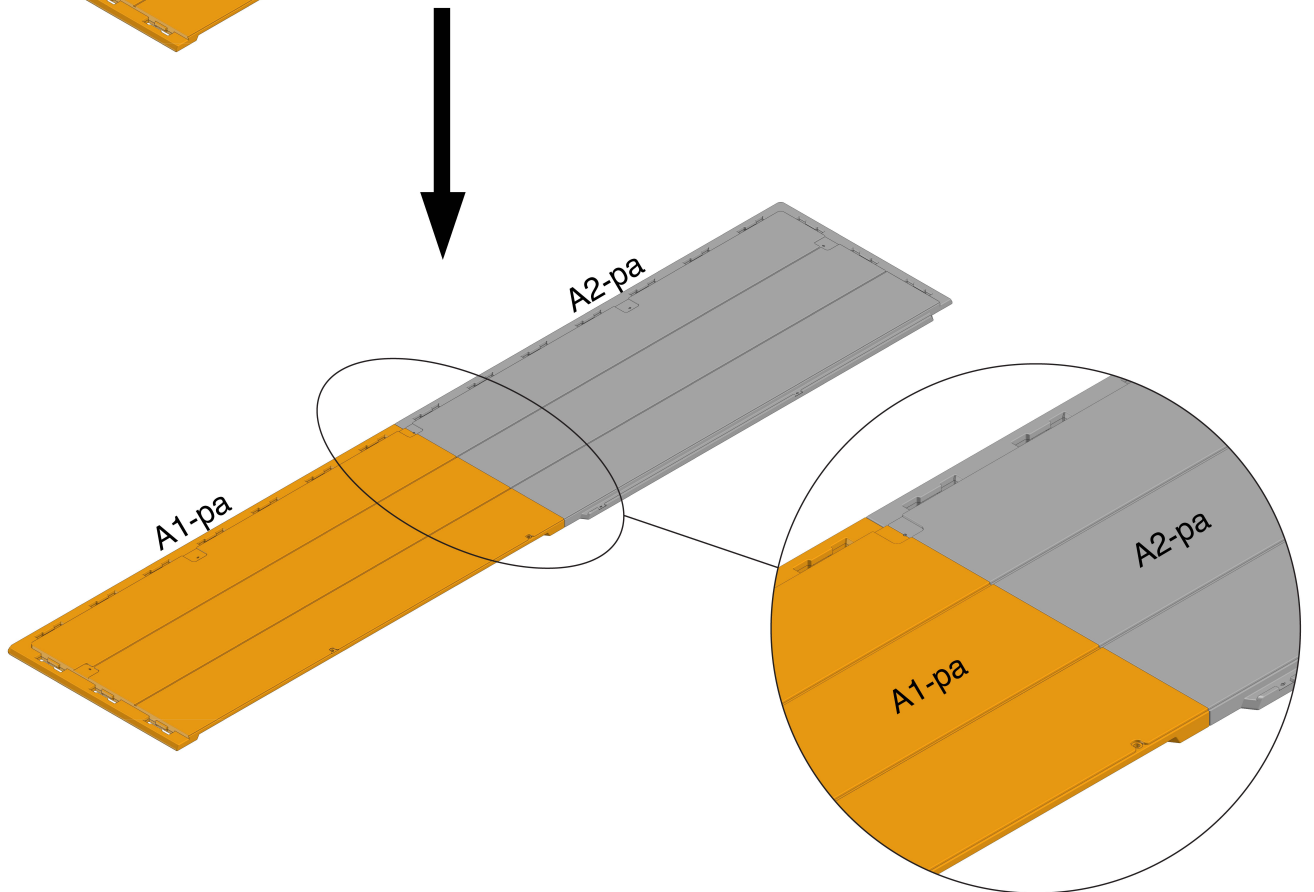
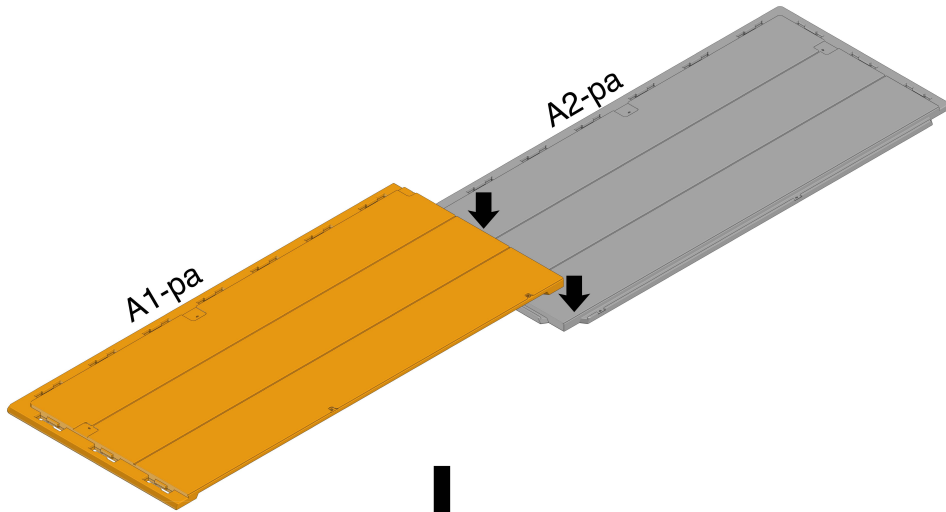
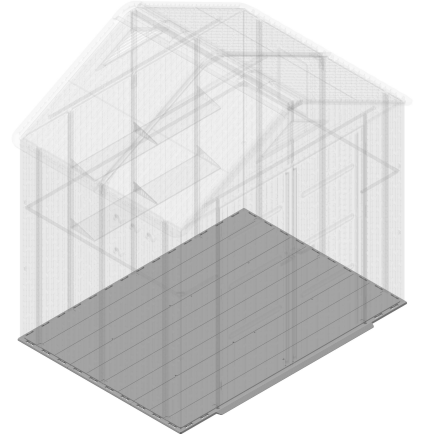
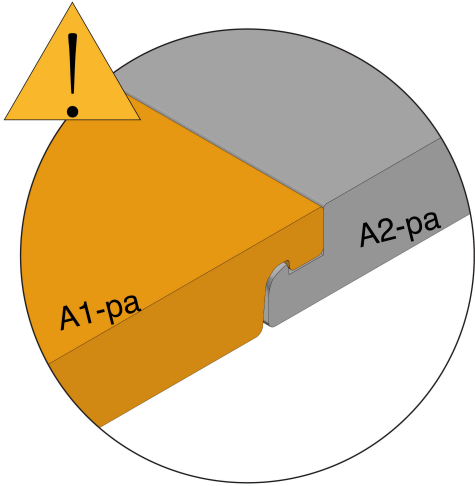
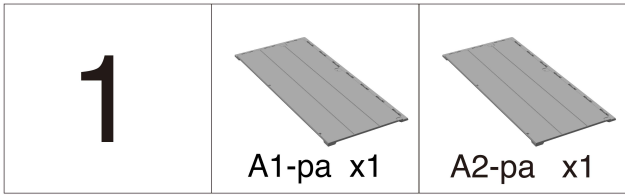

2

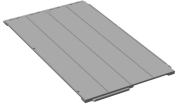

A3-pa x2

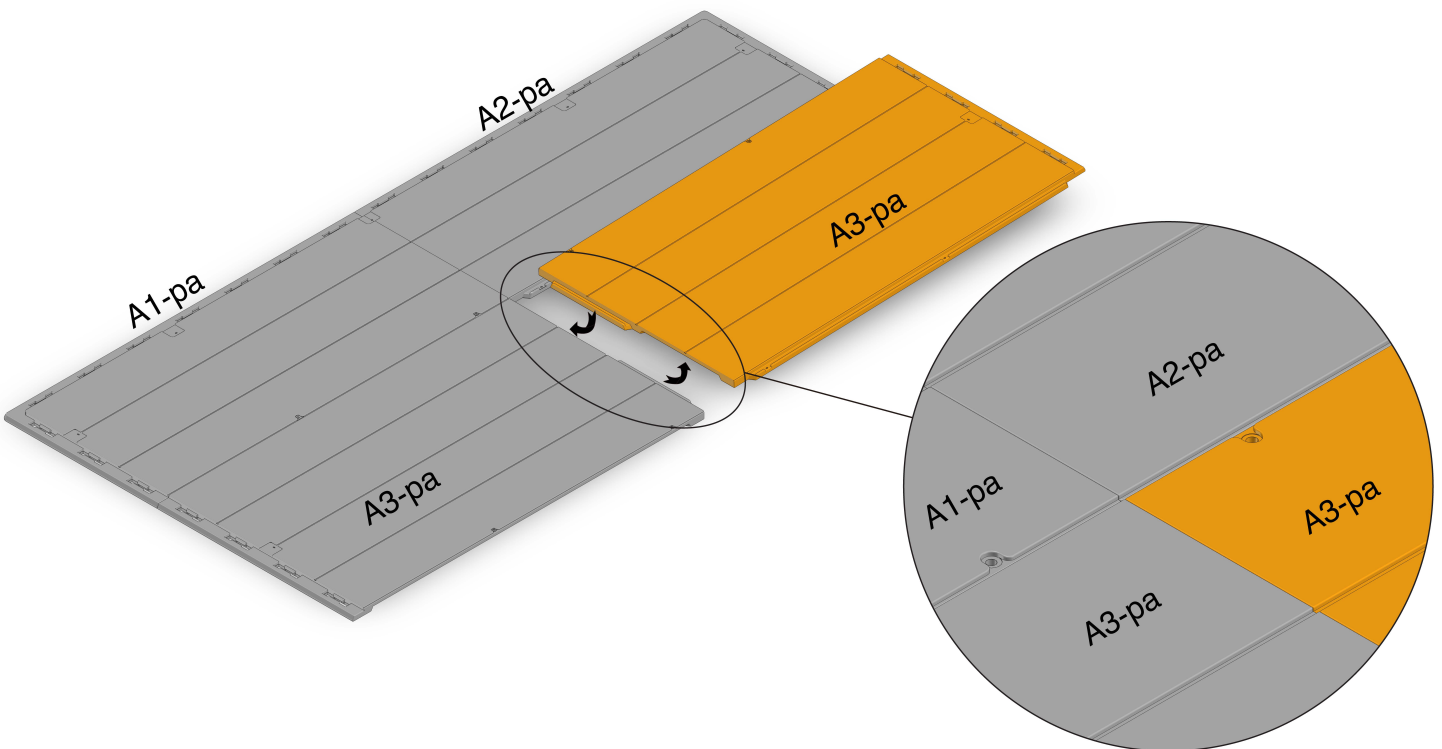
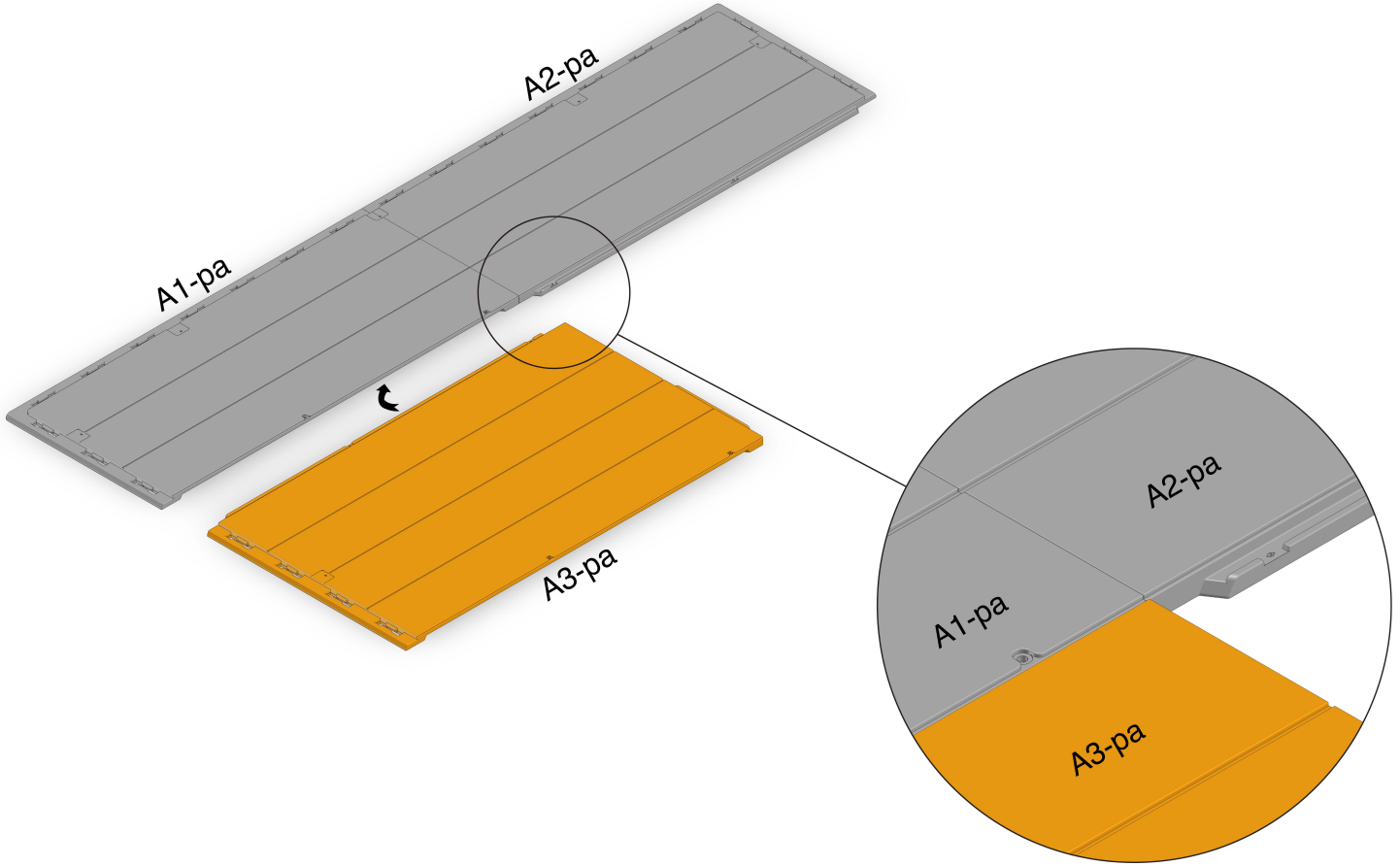

3

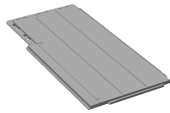

A4-pa x1

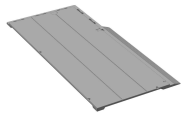

A5-pa x1



A58-pa x9

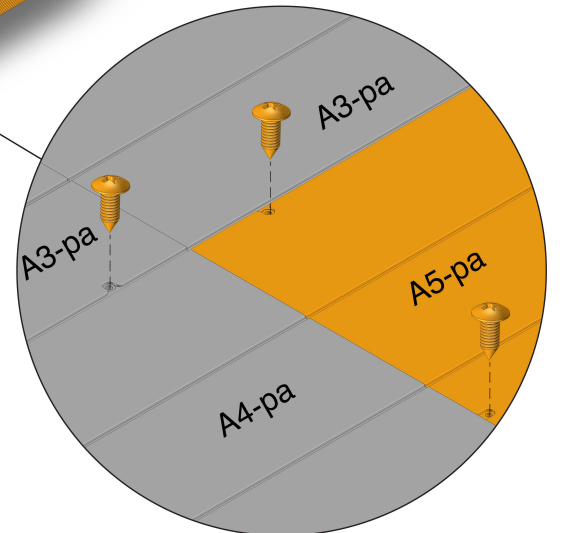
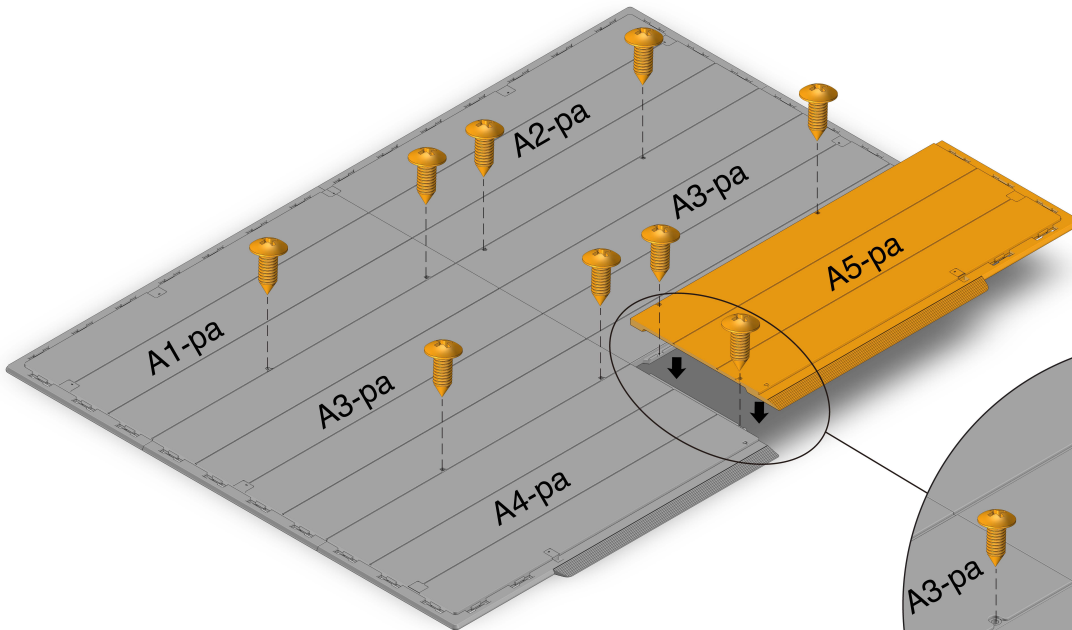
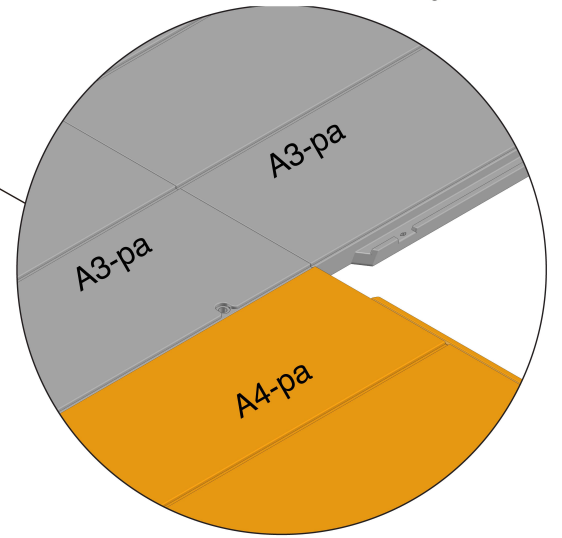
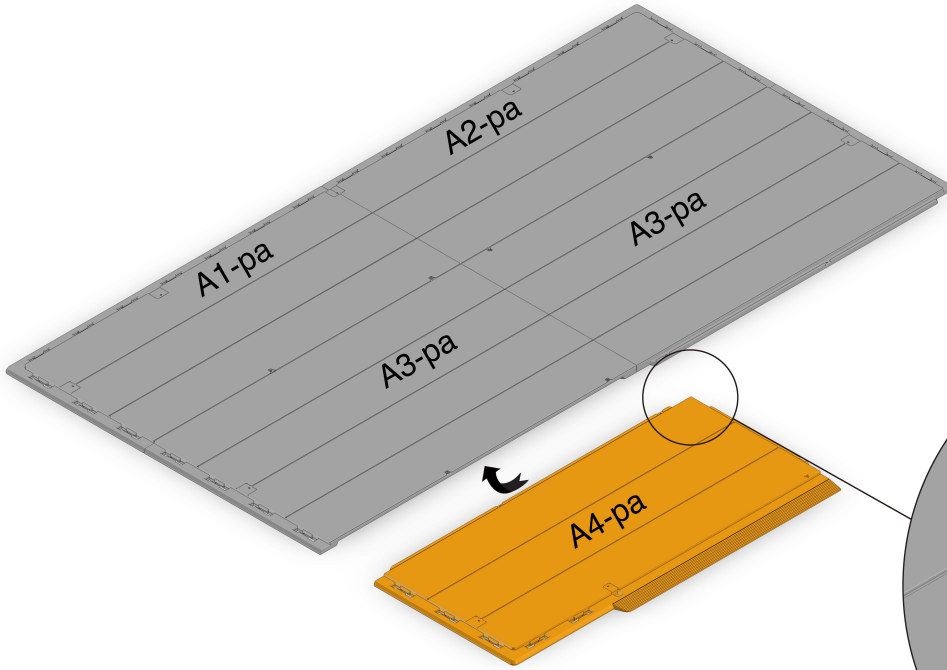
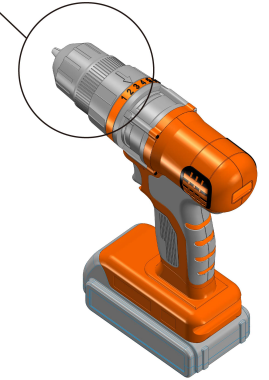
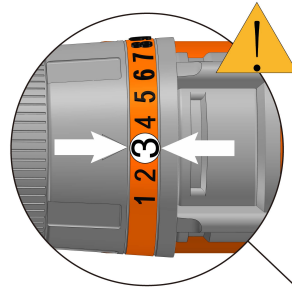

4



A6-pa x1

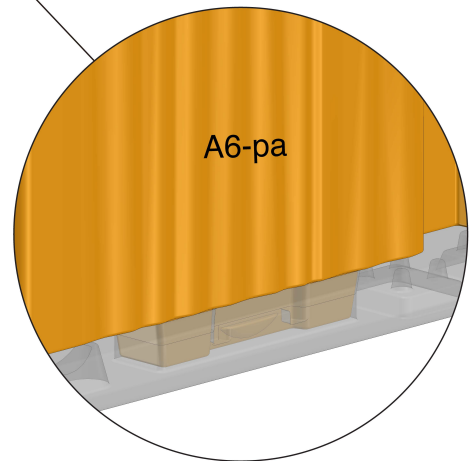
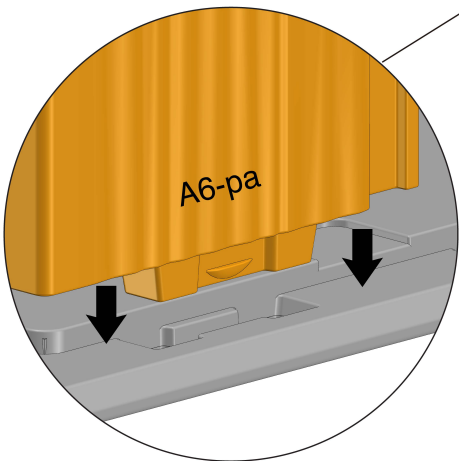
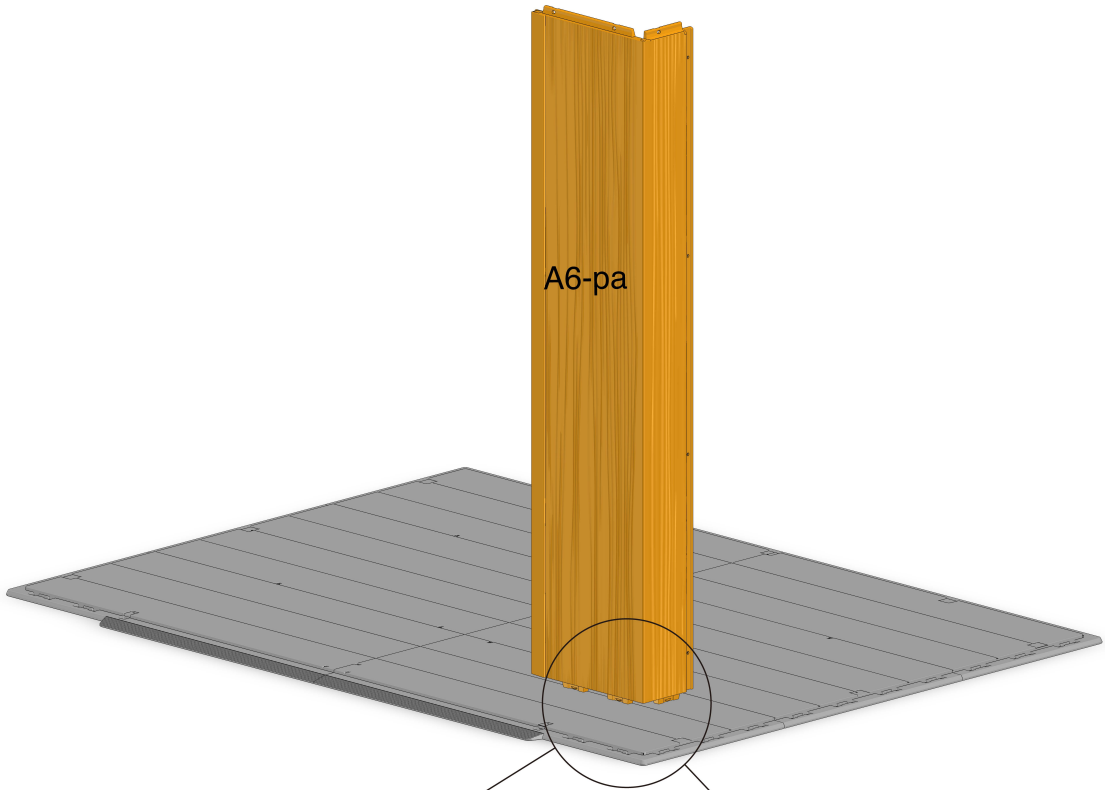
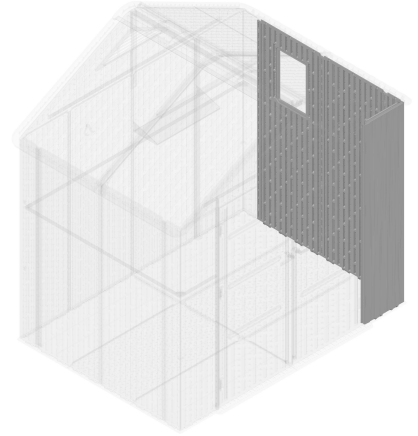
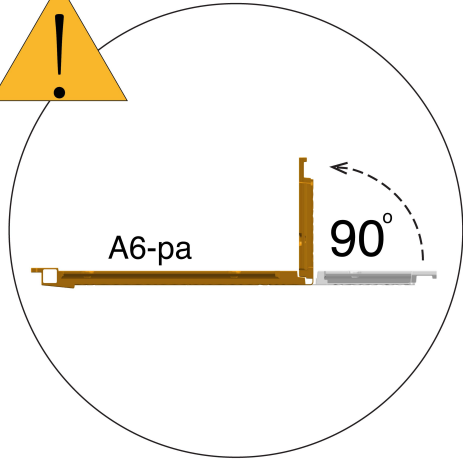

5

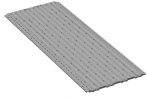

A7-pa x1

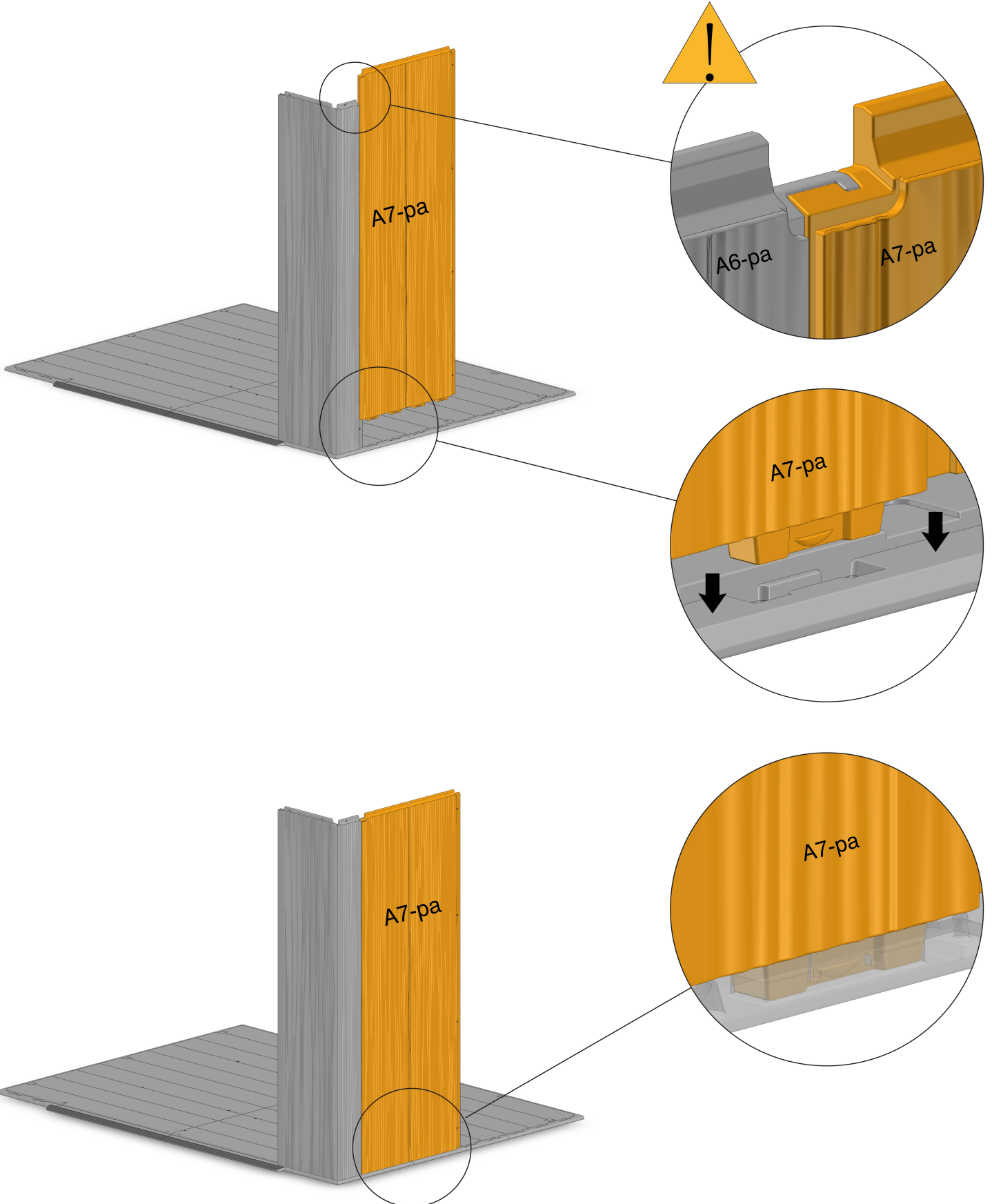

6



A8-pa x1

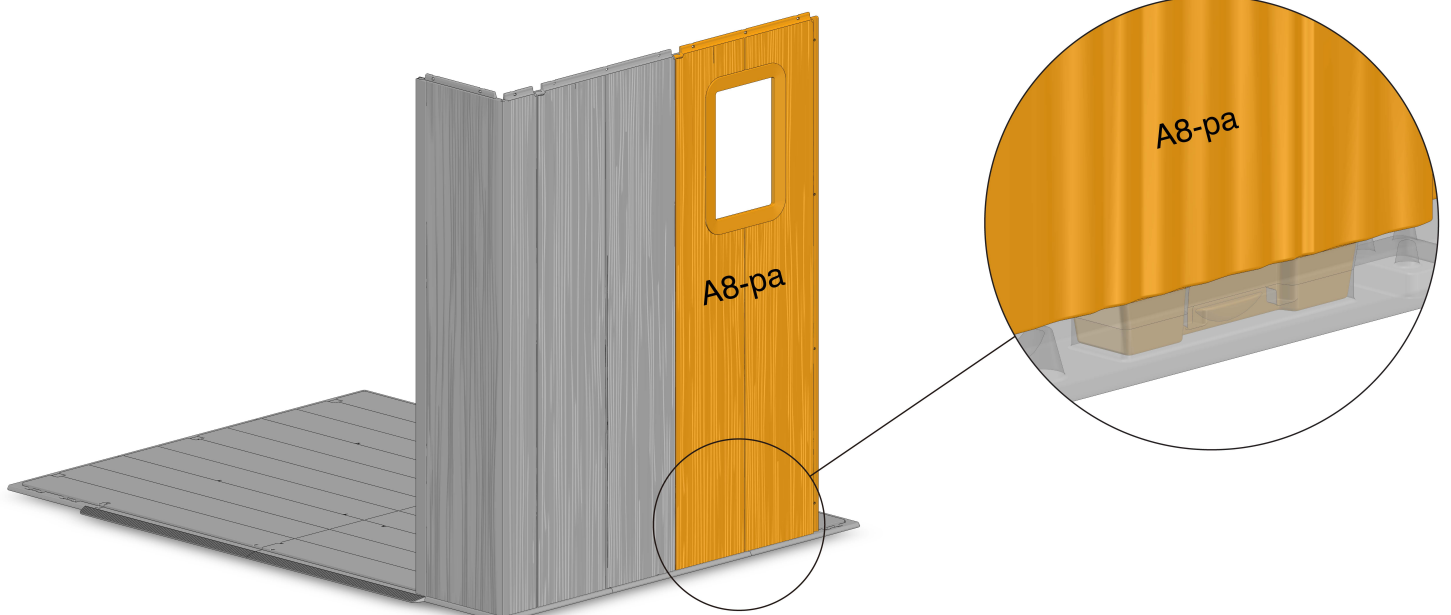
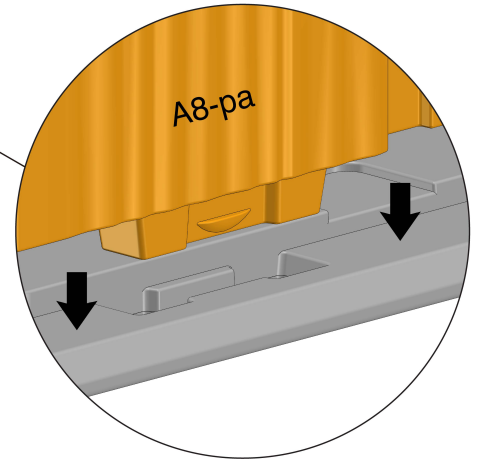
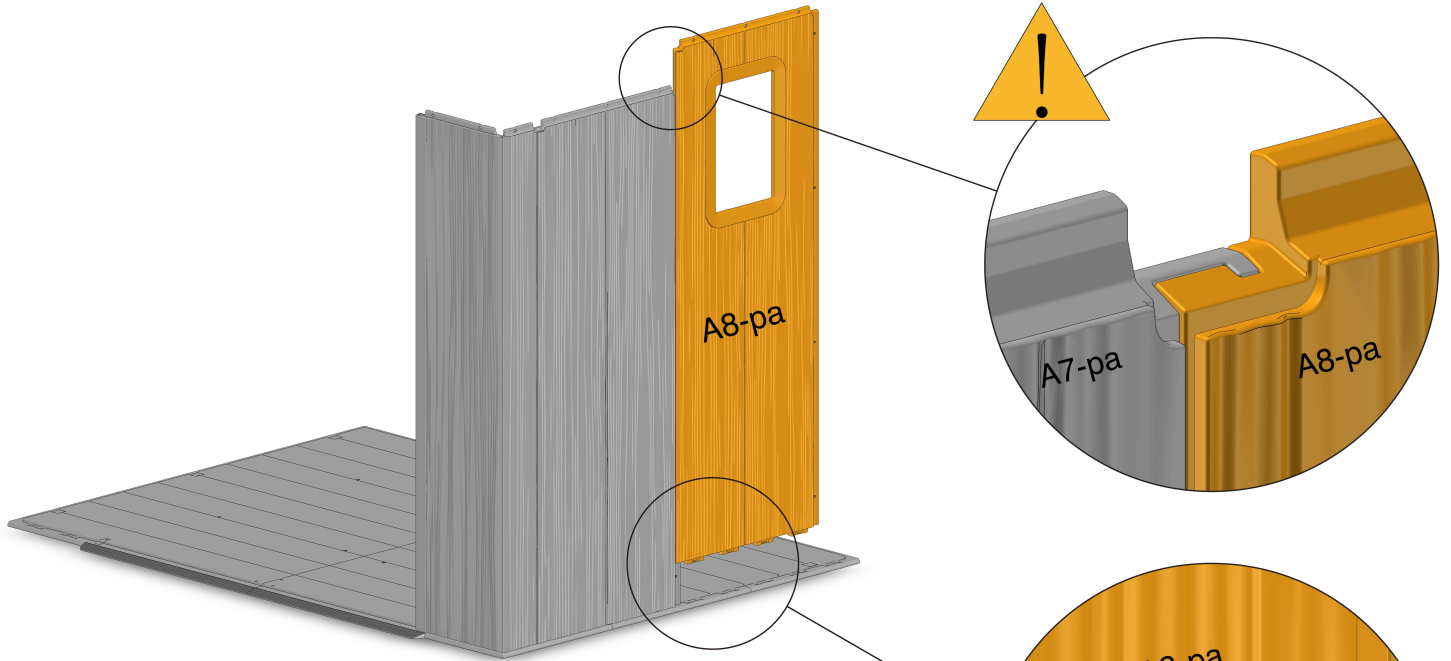

7

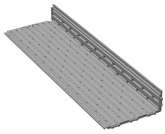

A9-pa x1

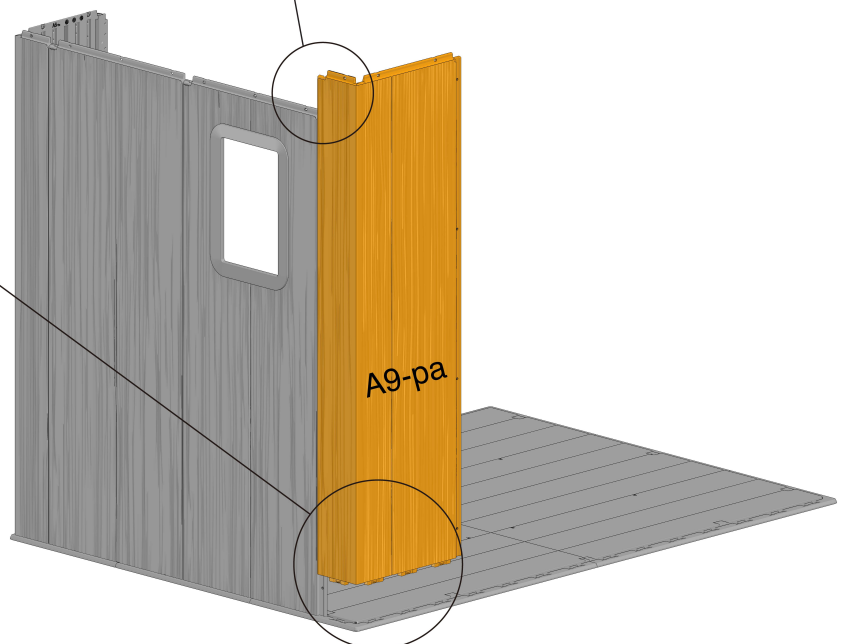
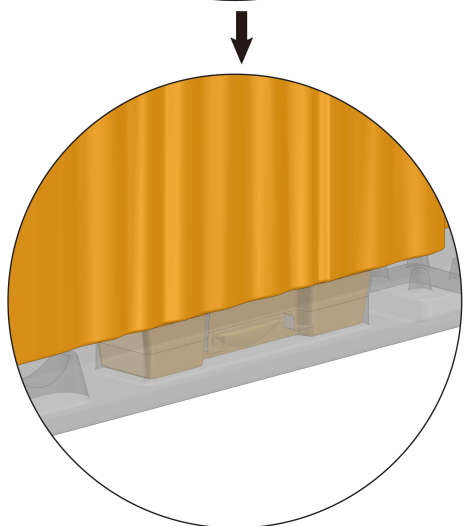
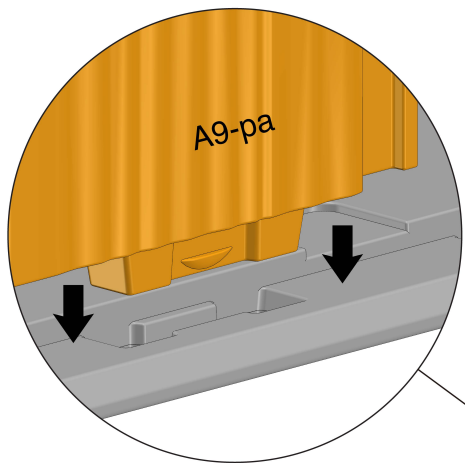
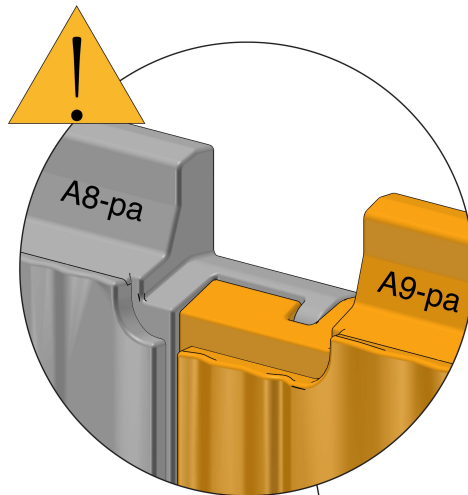
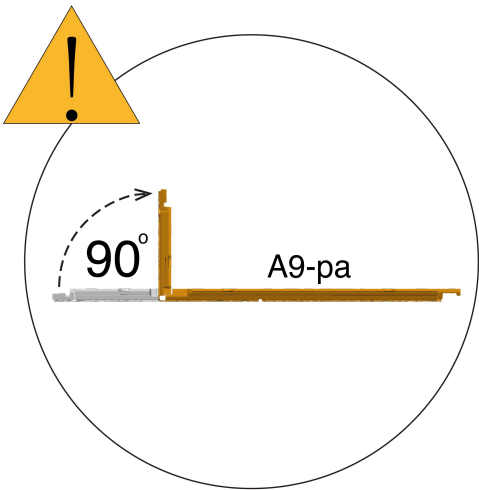
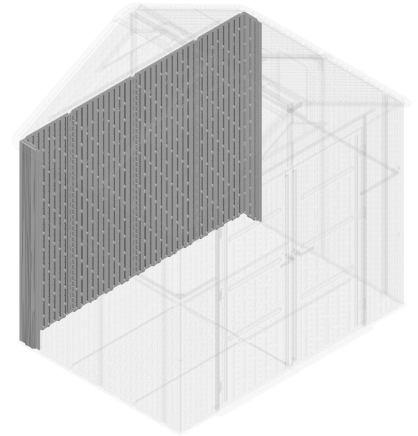

8

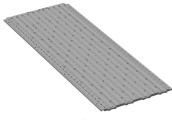

A7-pa x2

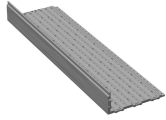

A10-pa x1

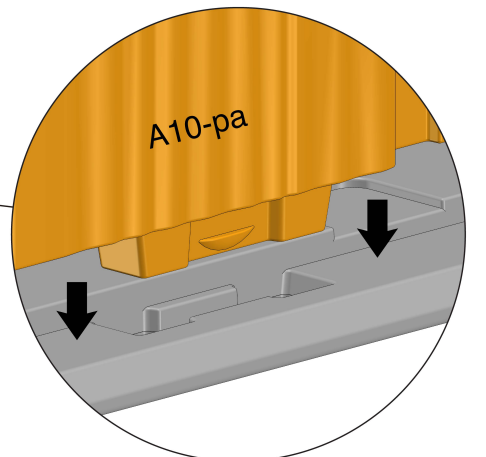
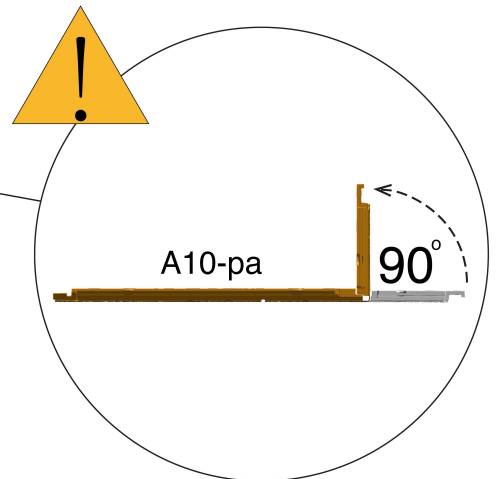
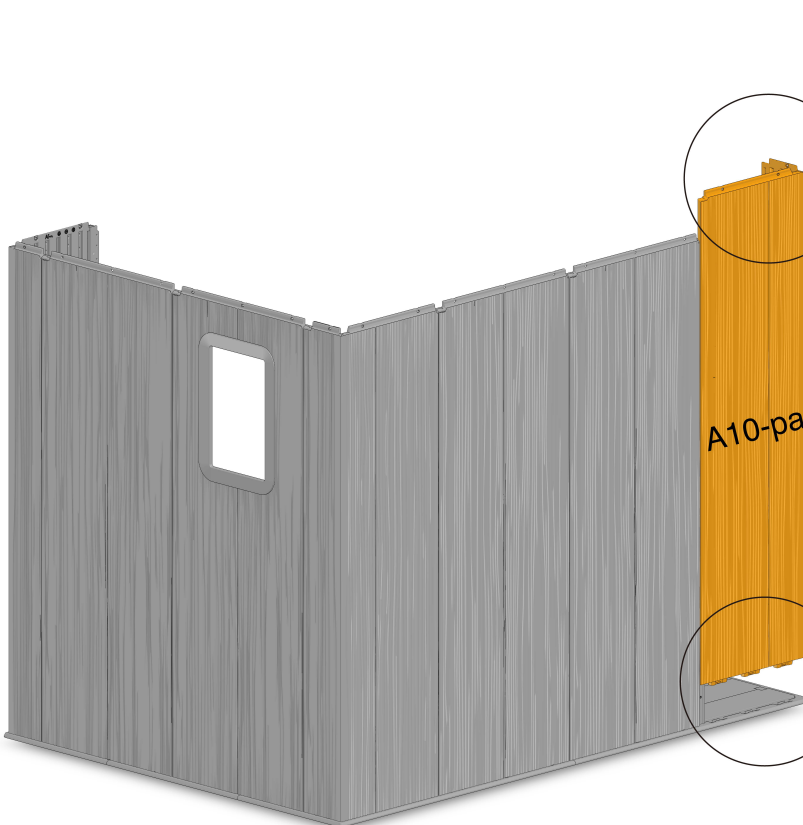
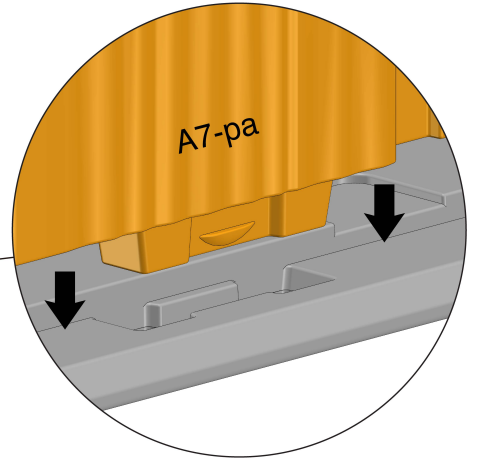
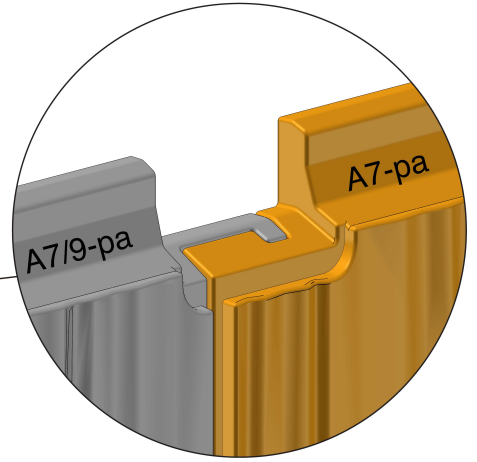
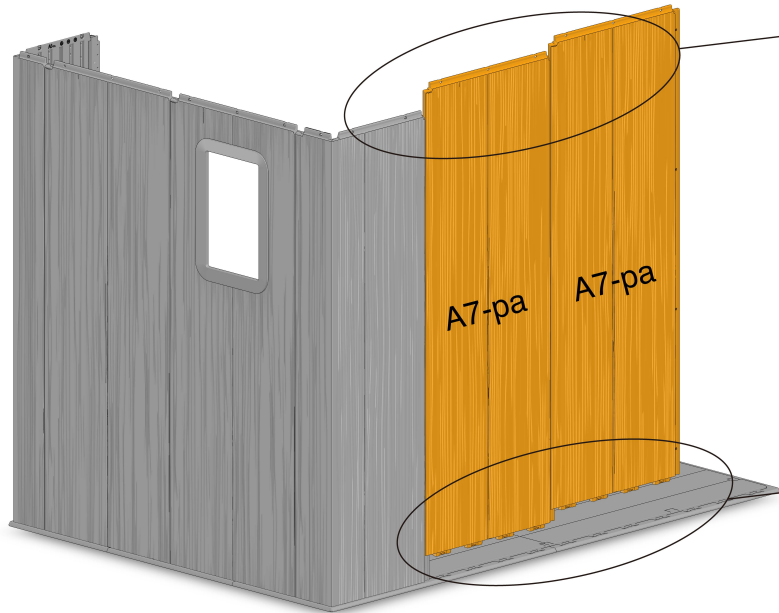

9

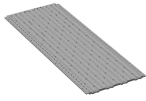

A7-pa x2

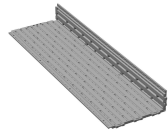

A11-pa x1

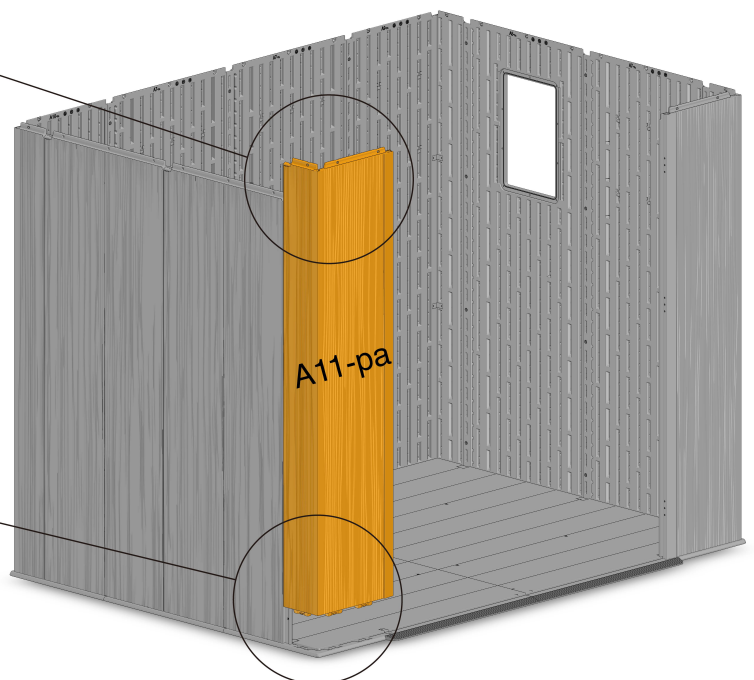
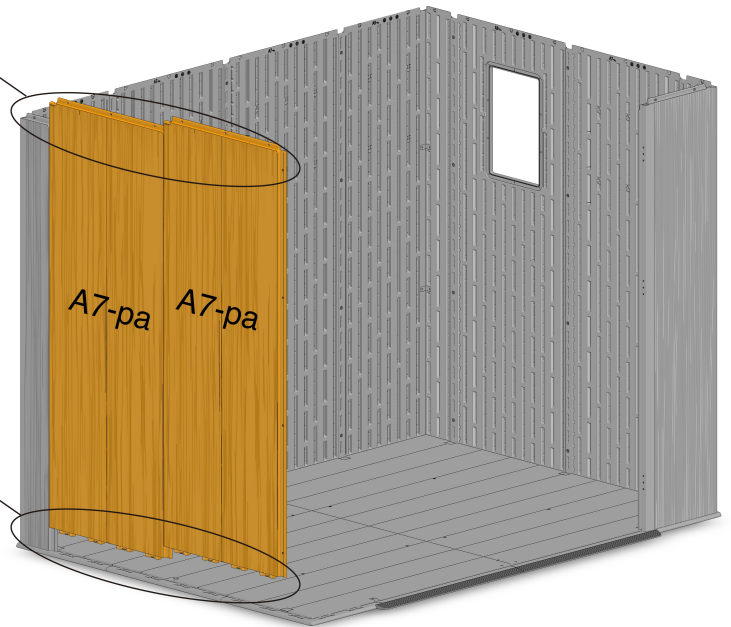
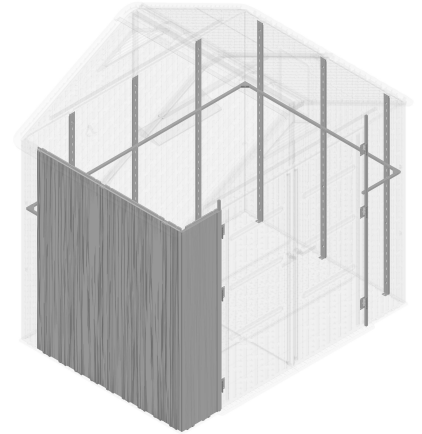
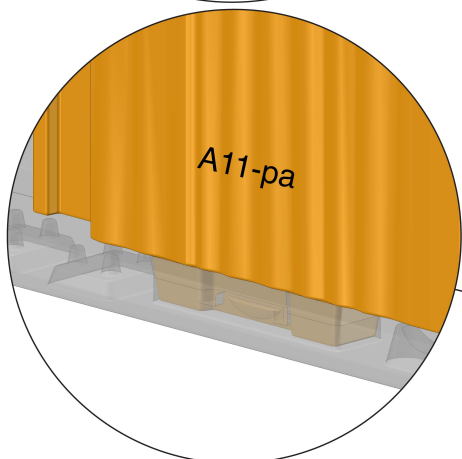
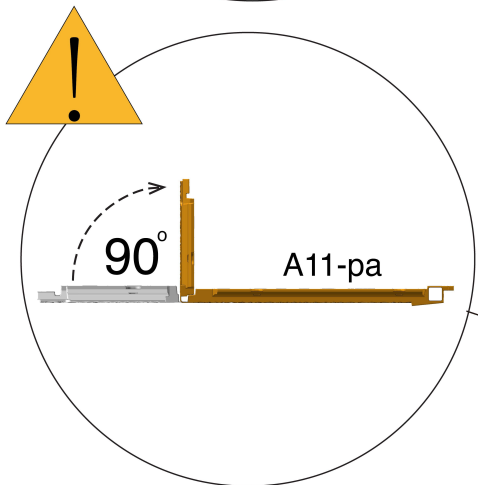
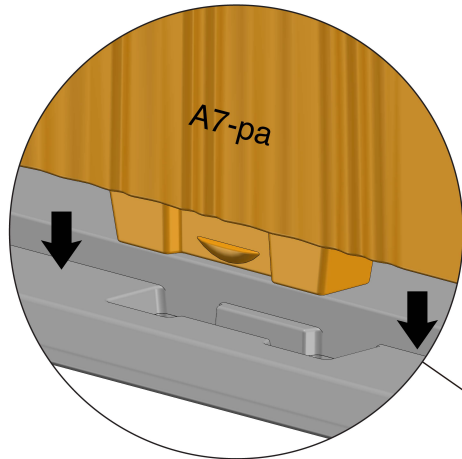
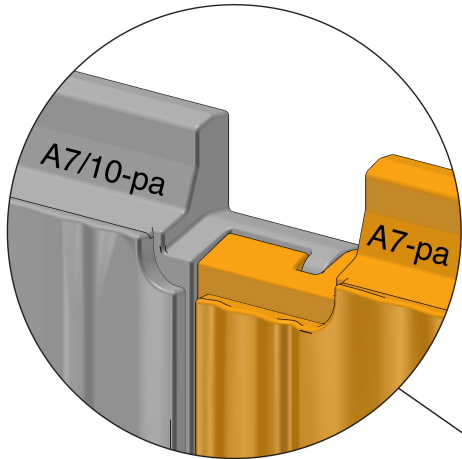

10

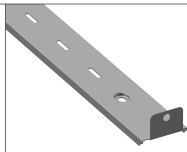

A30-pa x6



A54-pa x18

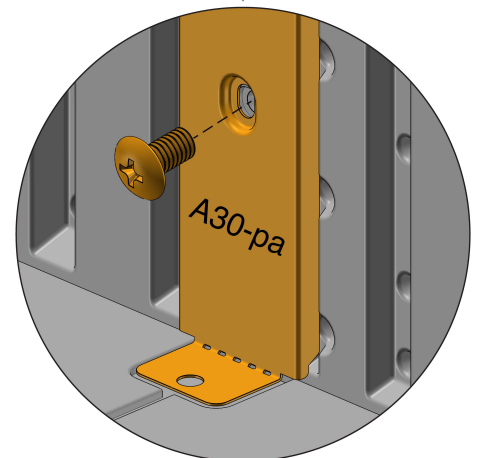
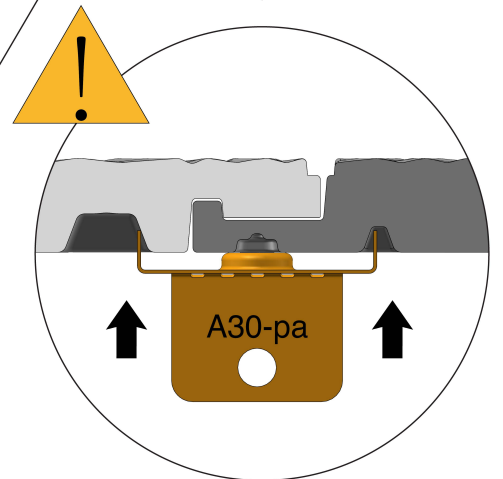
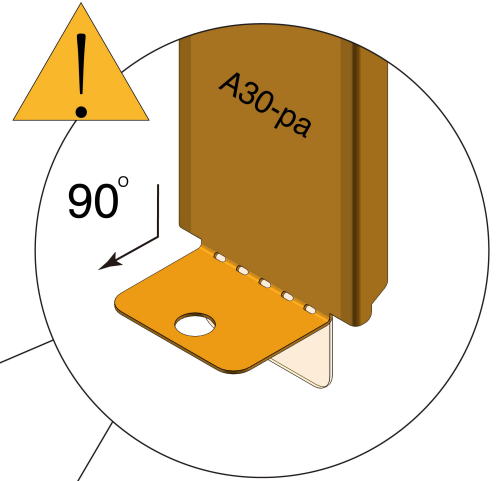
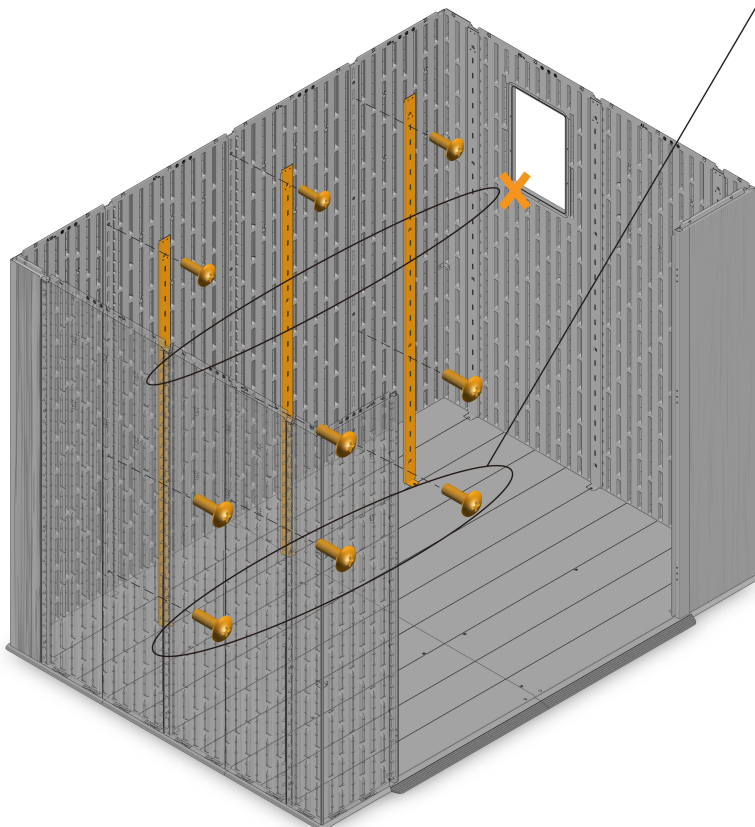
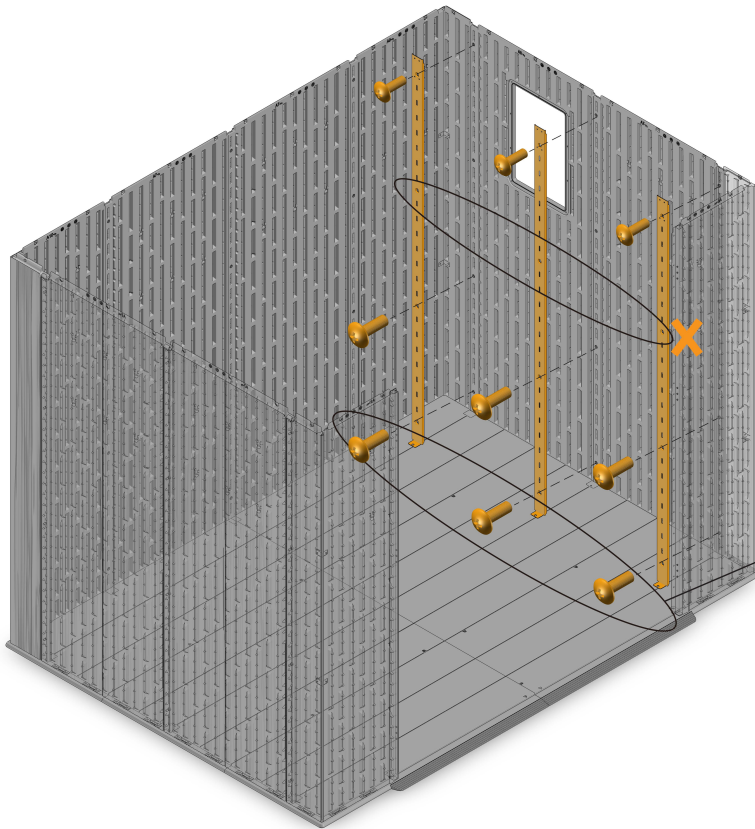

11

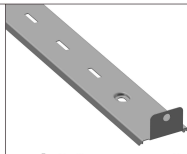

A30-pa x3



A54-pa x9

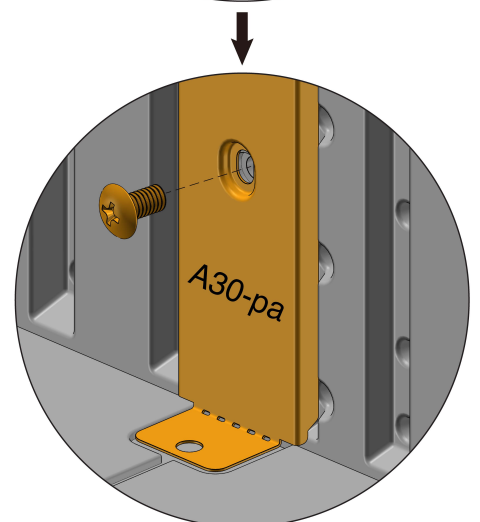
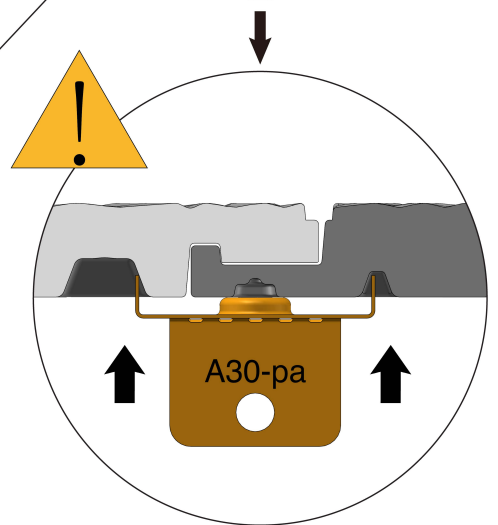
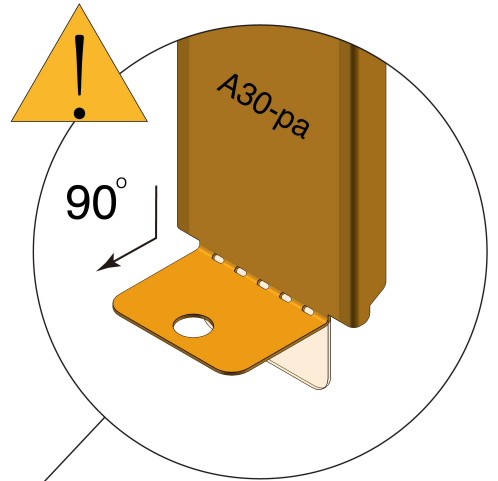
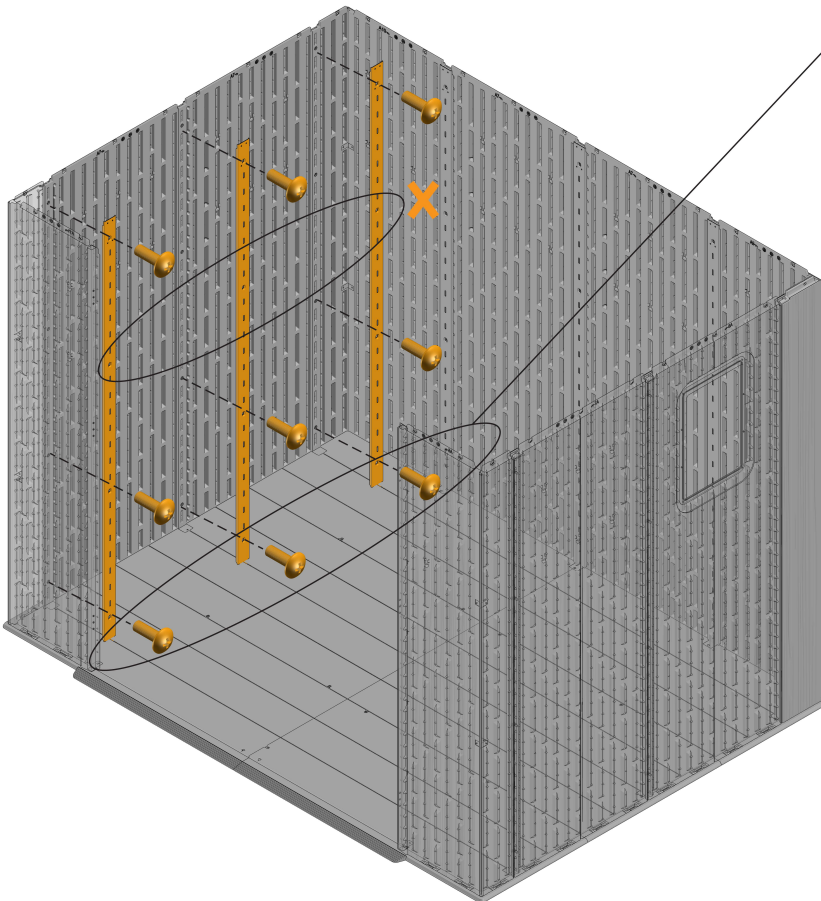

12

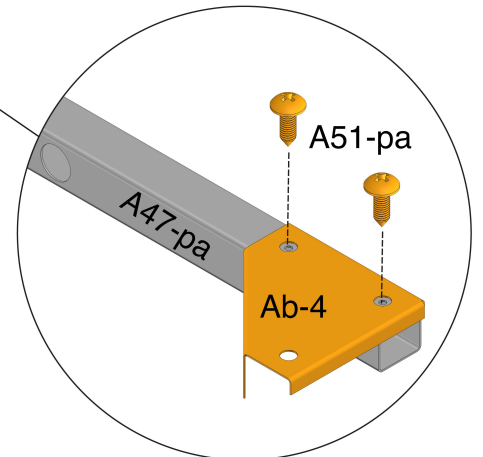
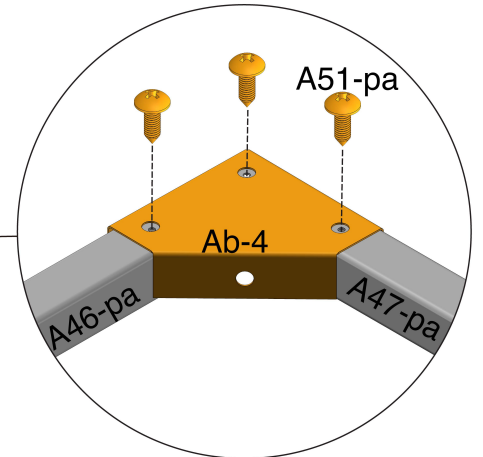
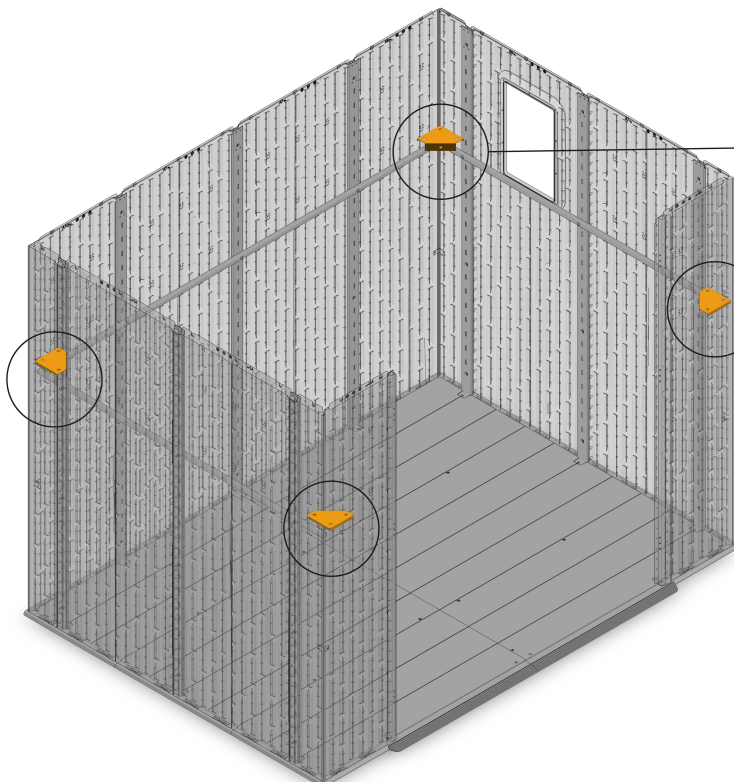
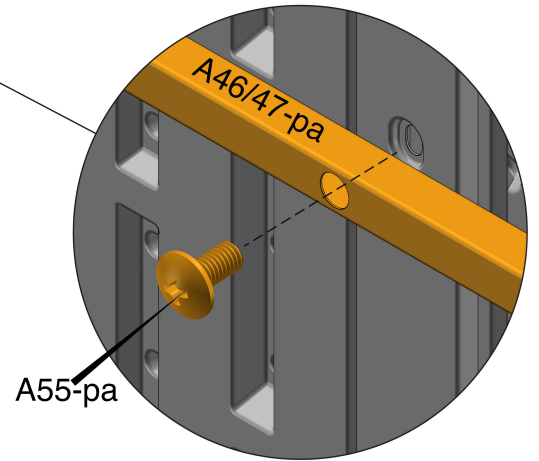
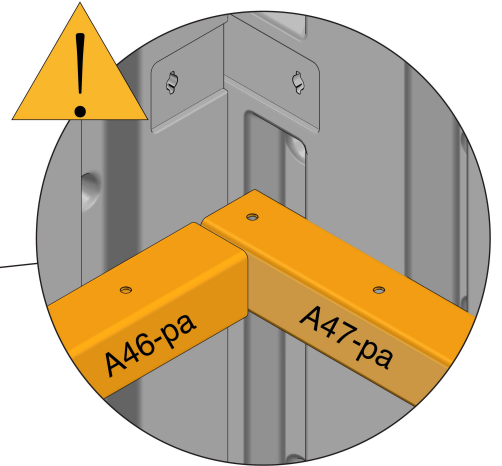
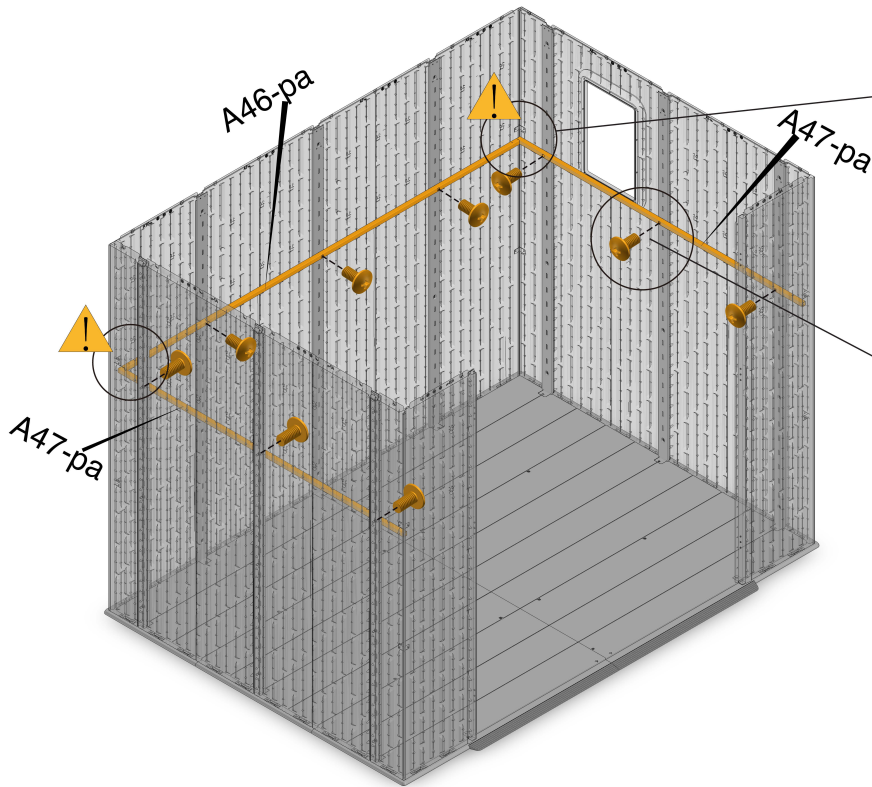
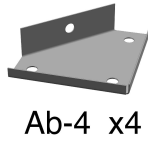
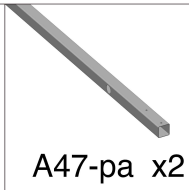
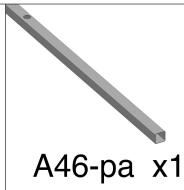

13

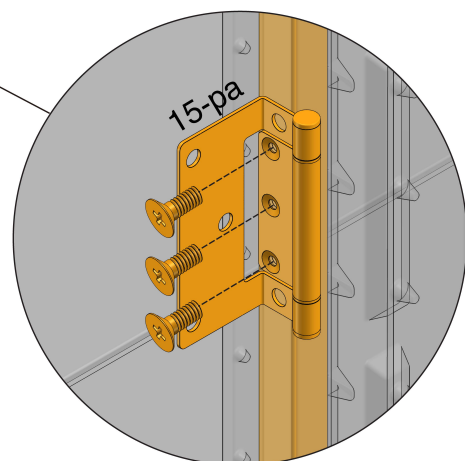
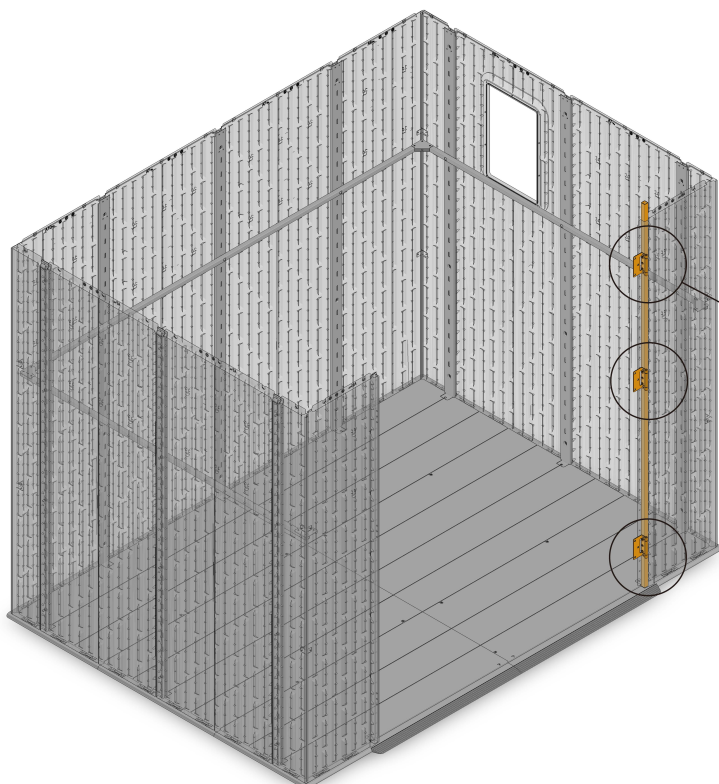
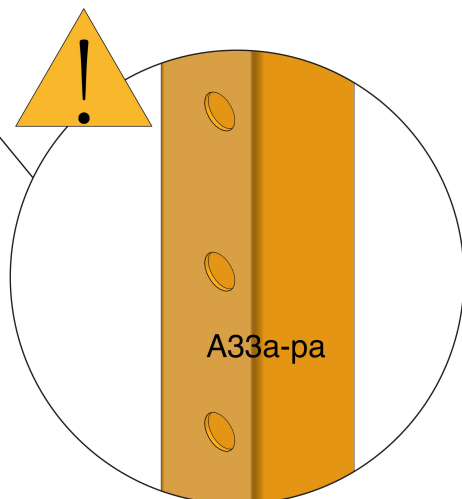
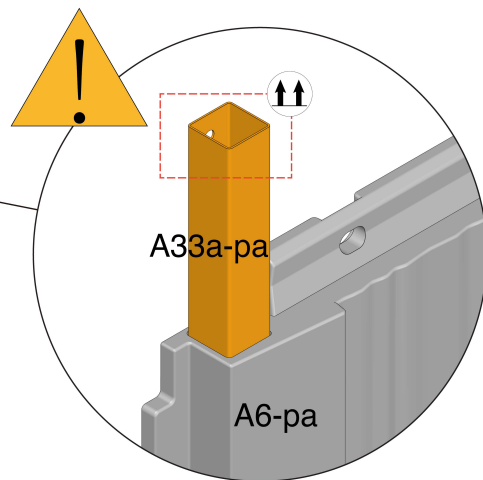
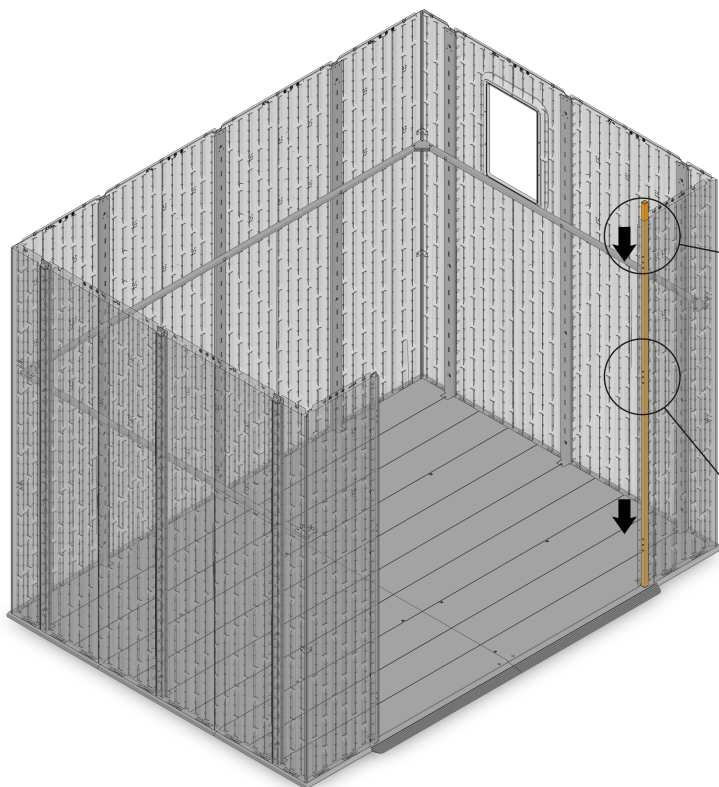
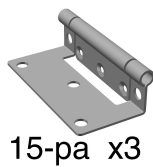
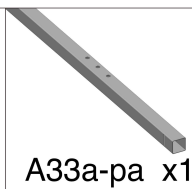

14

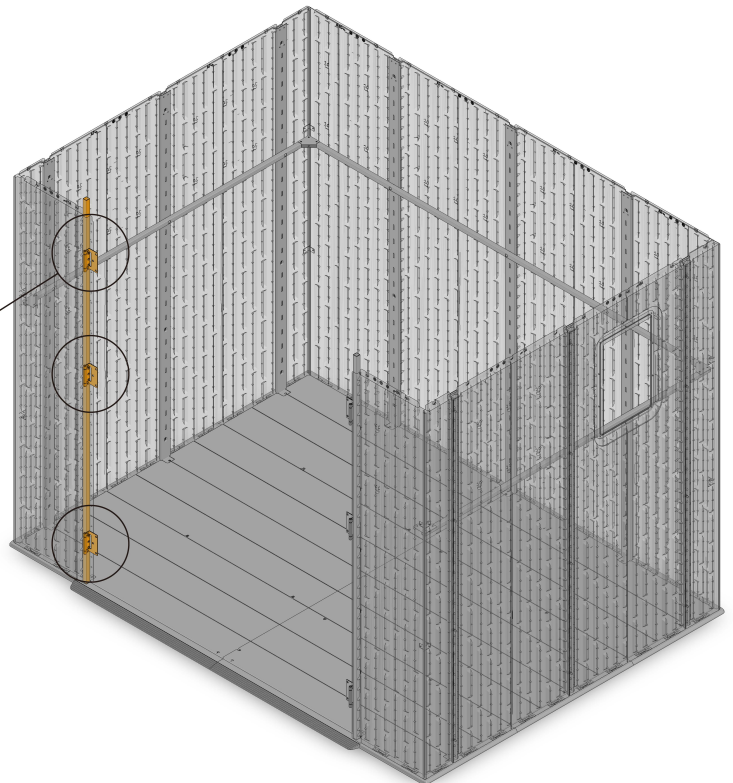
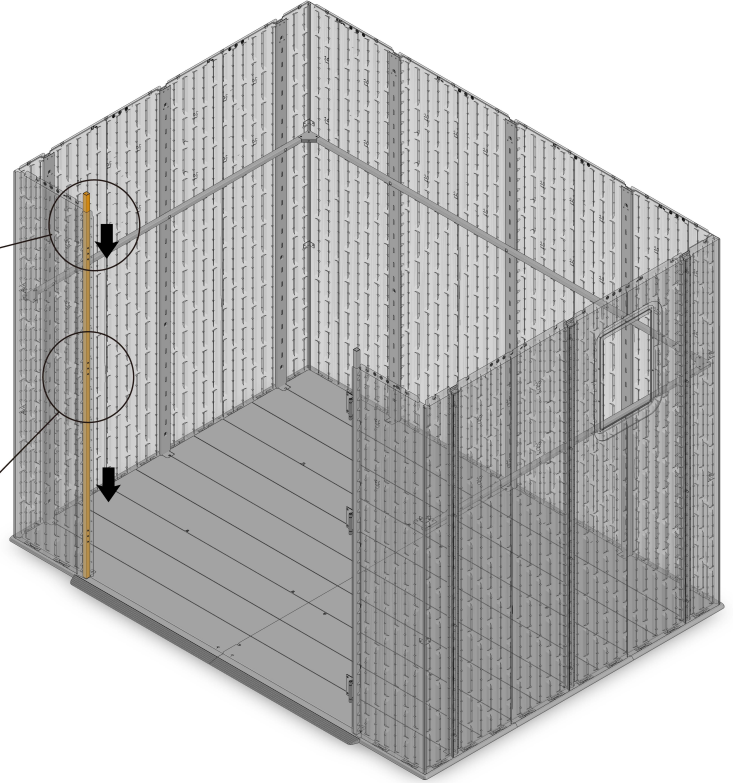
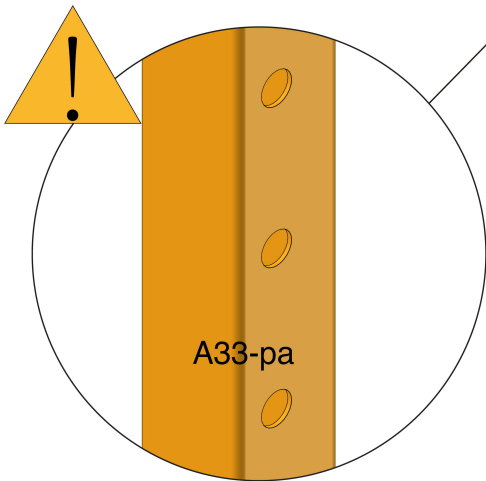
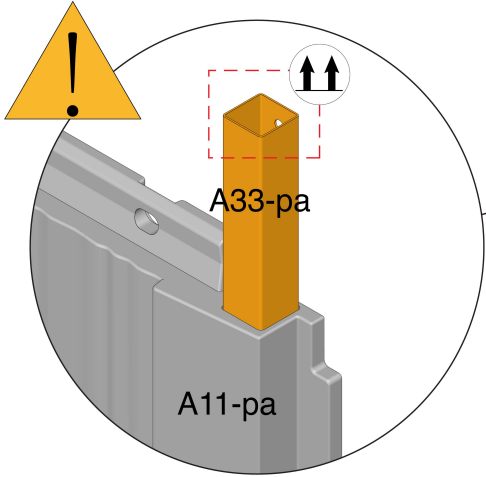
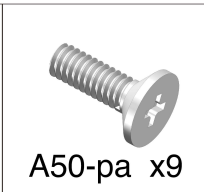
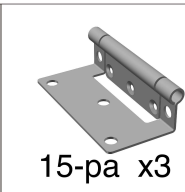
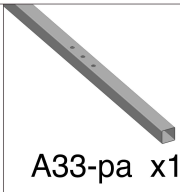

15

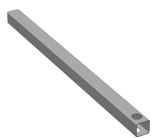

A48-pa x2



21-pa x2



16-pa x10



A51-pa x2



A52-pa x4



A58-pa x16

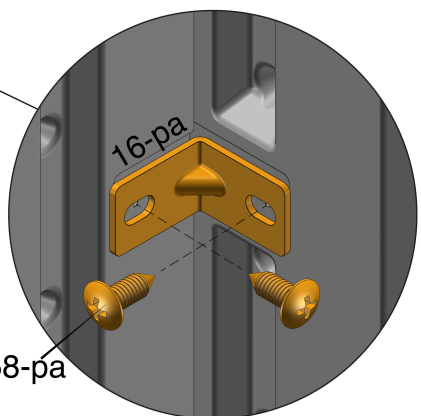
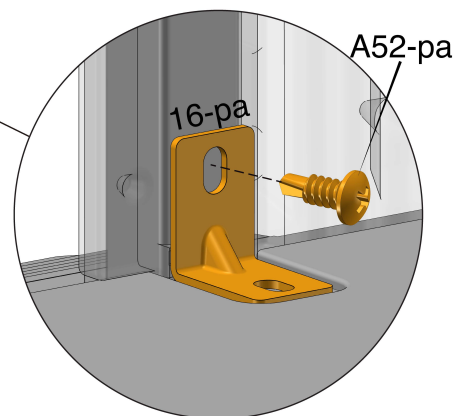
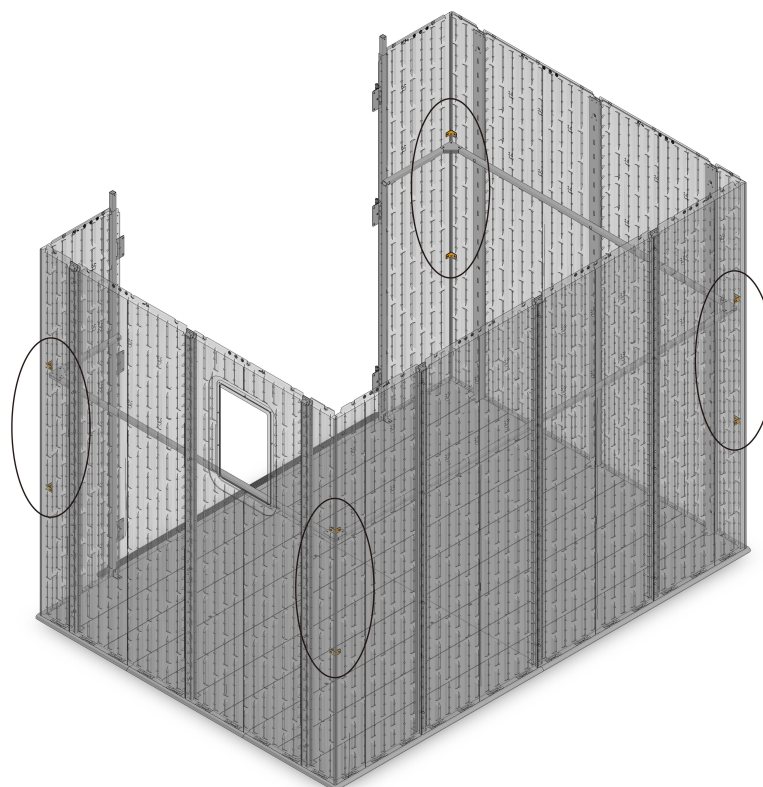
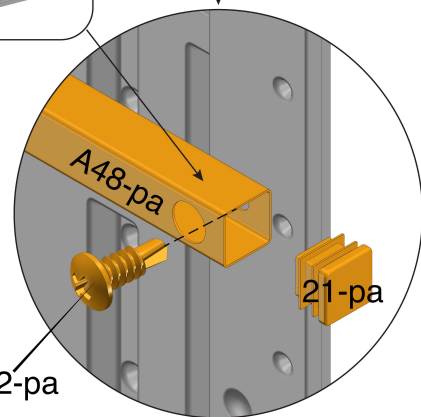
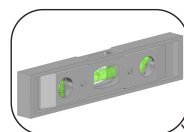
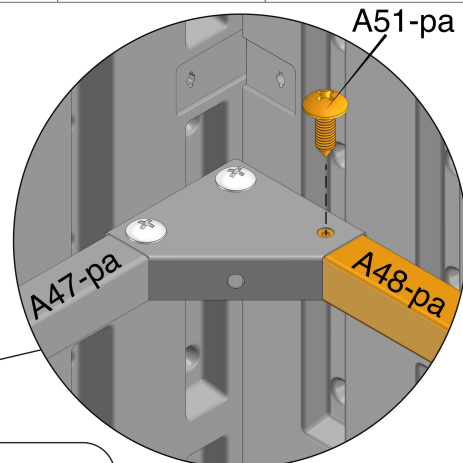
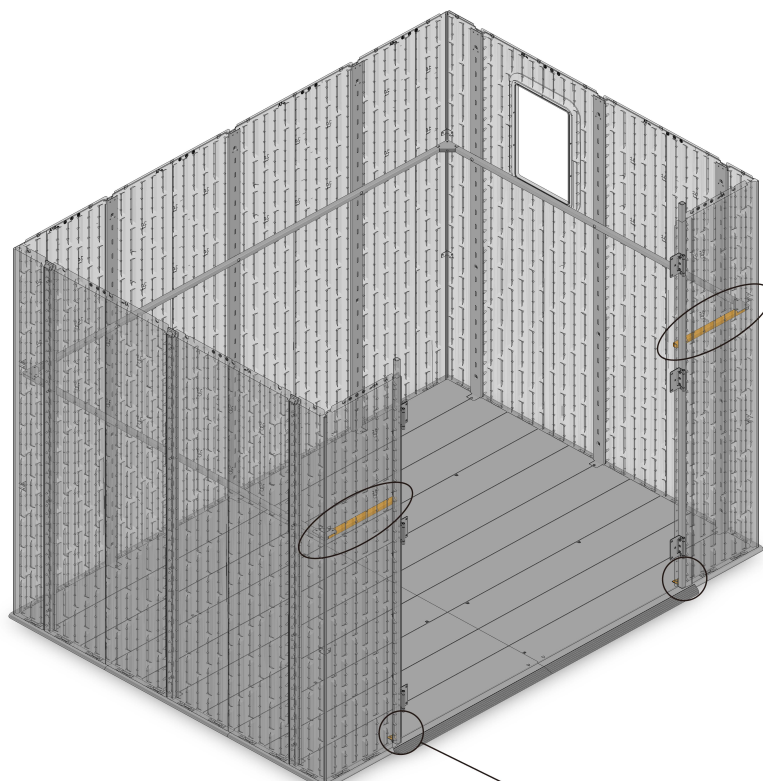

16

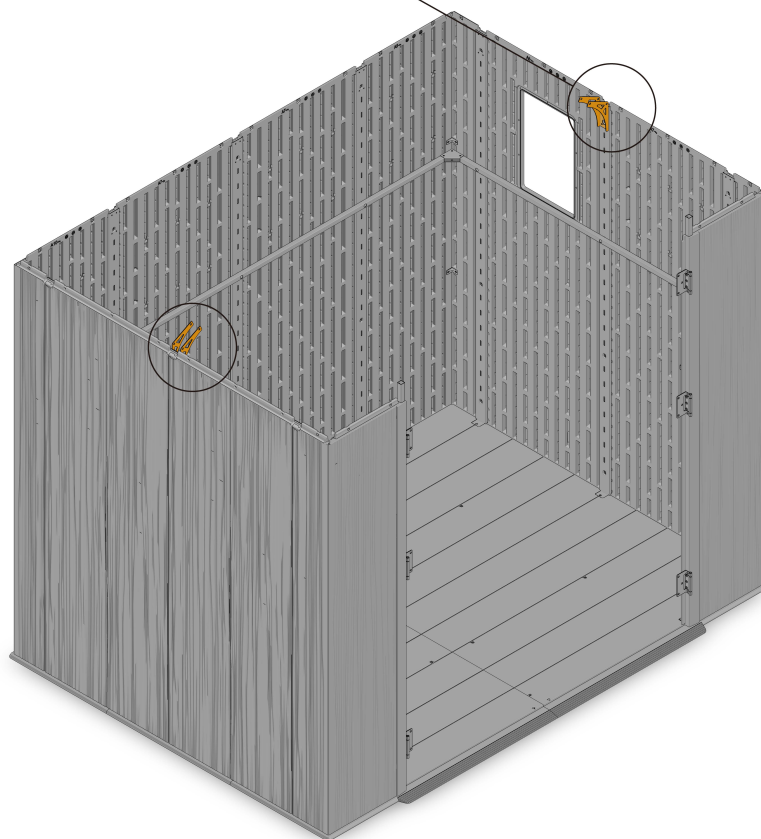
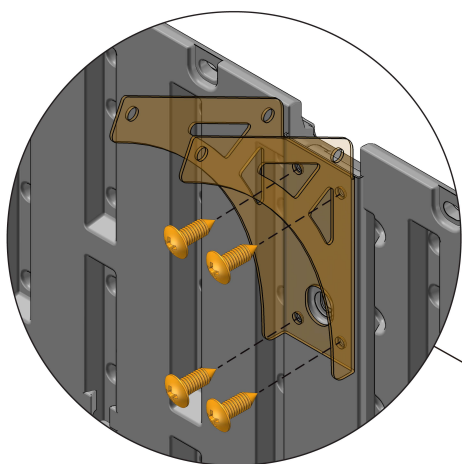
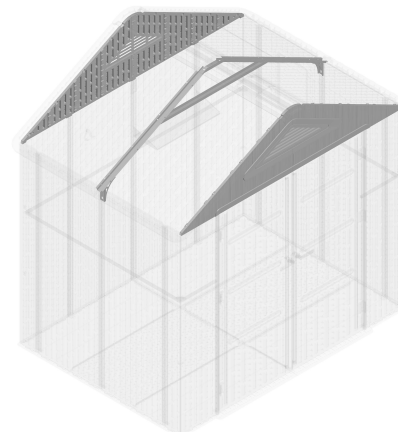

17

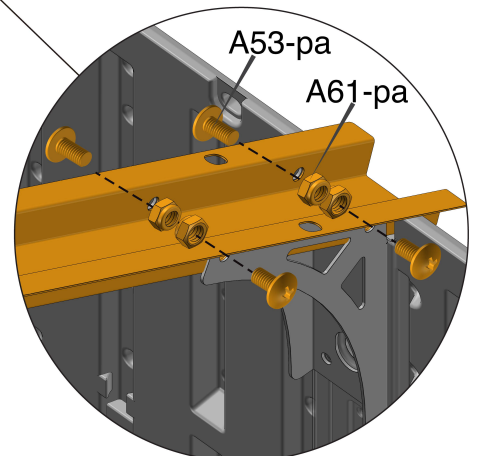
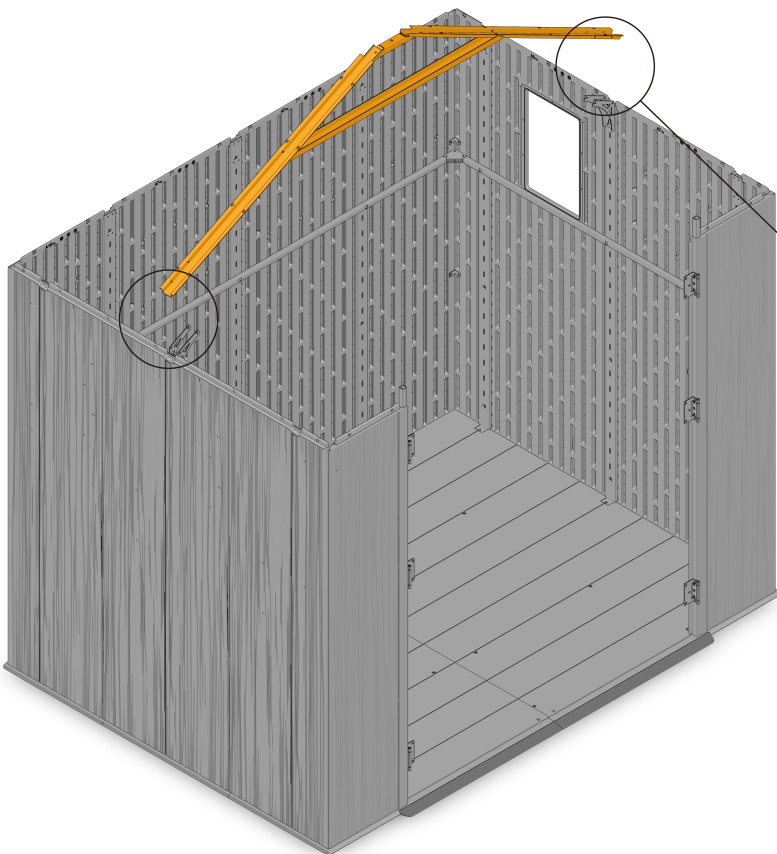
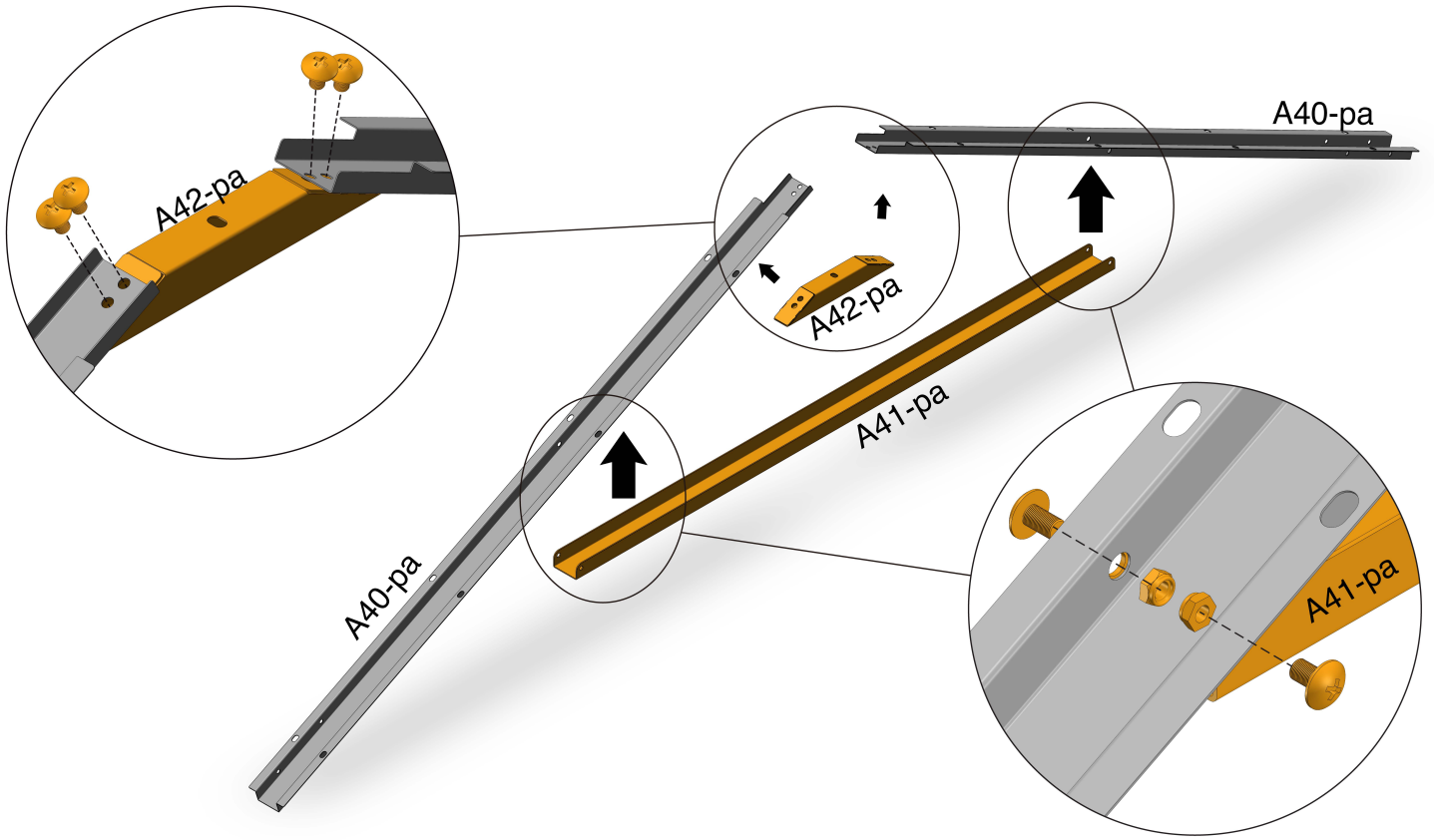
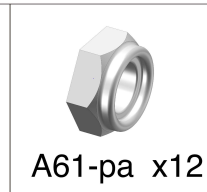
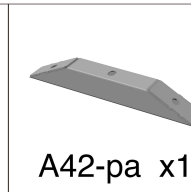
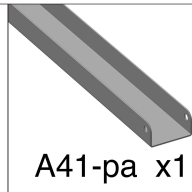
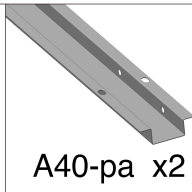

18

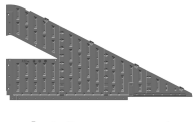

A12-pa x1

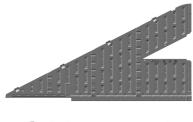

A13-pa x1



A24-pa x1



A54-pa x3



A51-pa x6

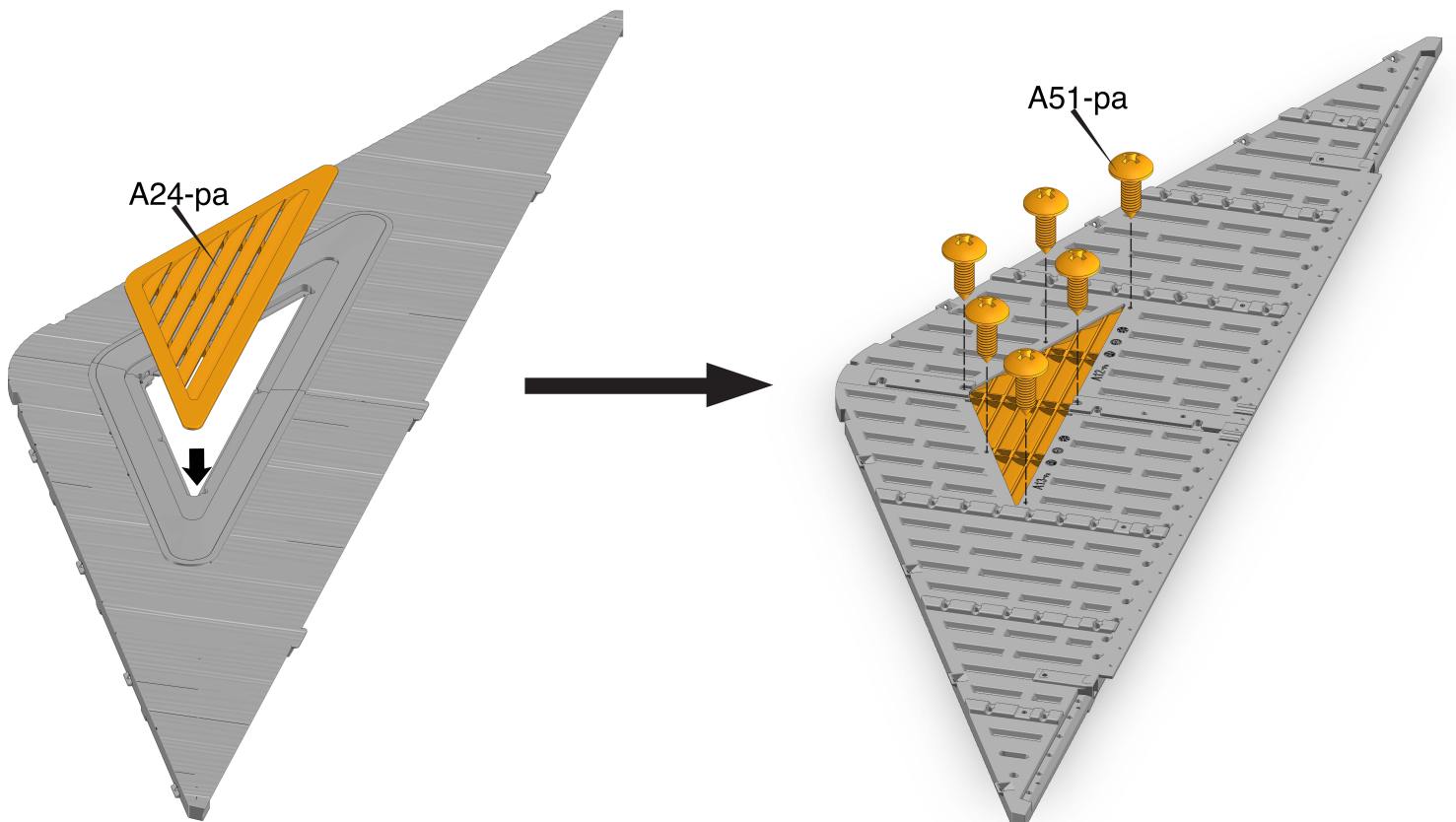
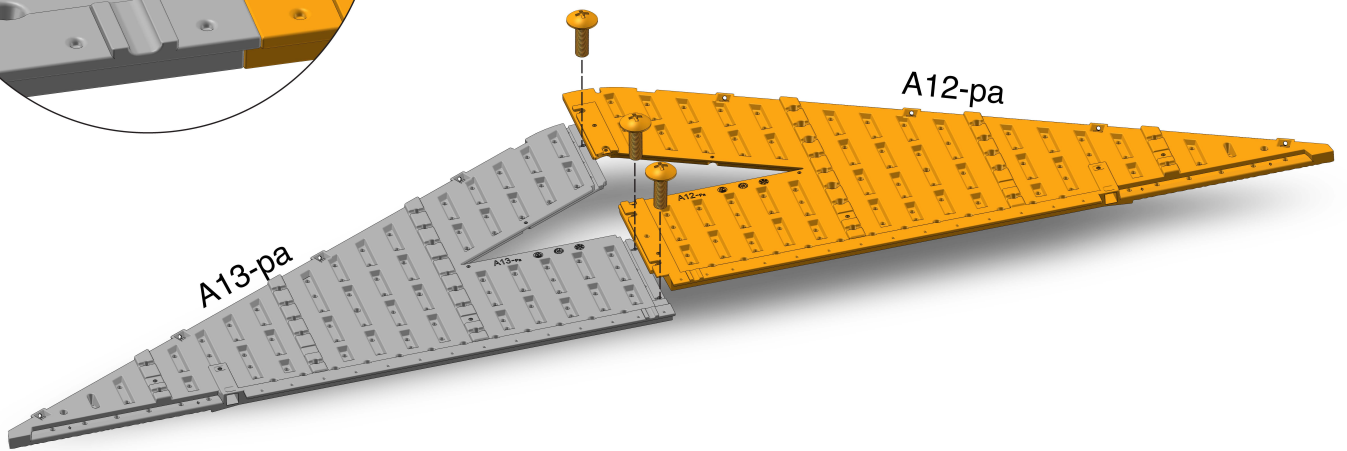
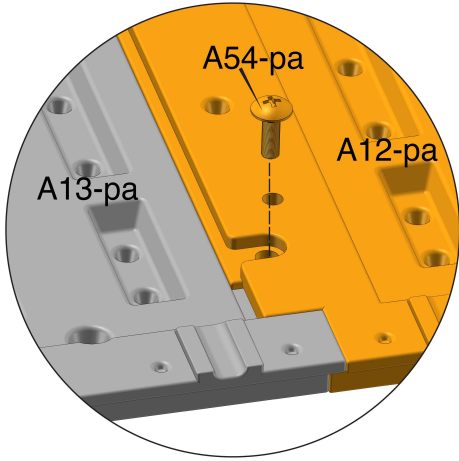

19

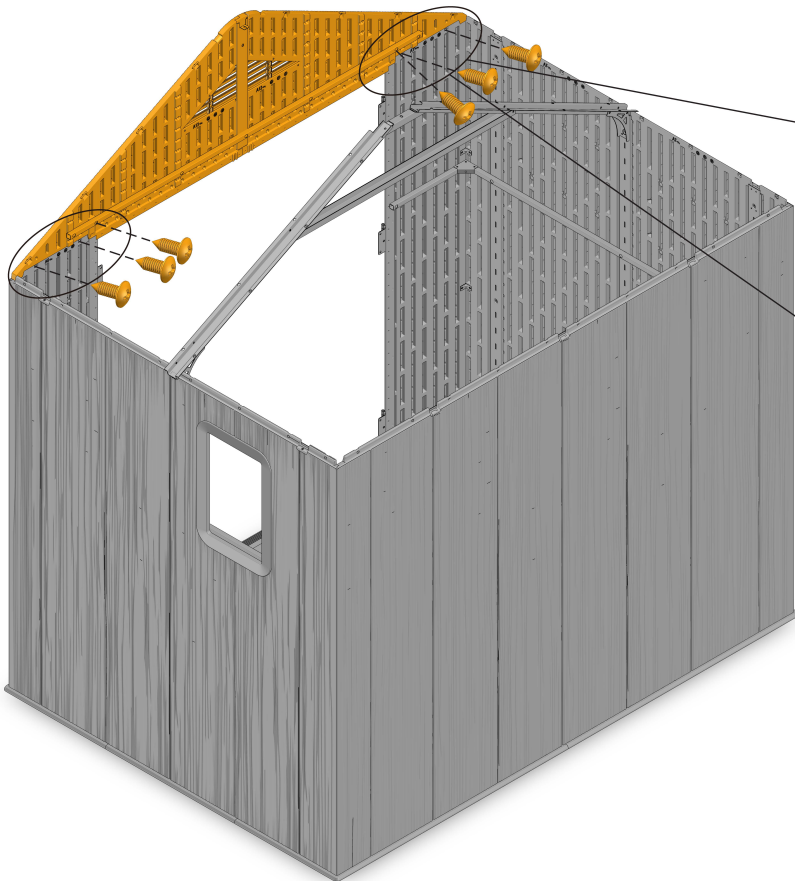
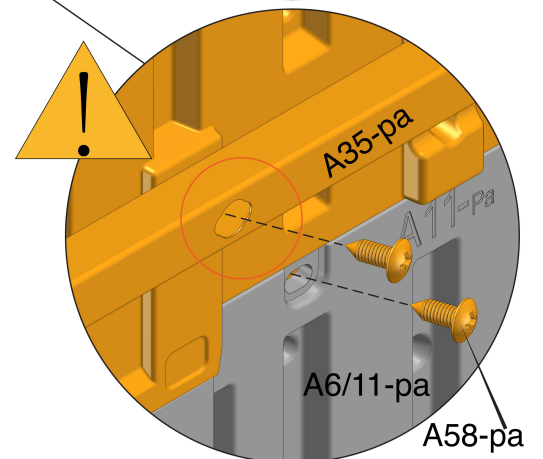
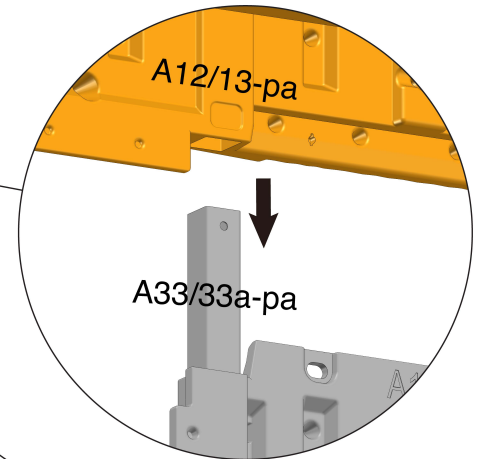
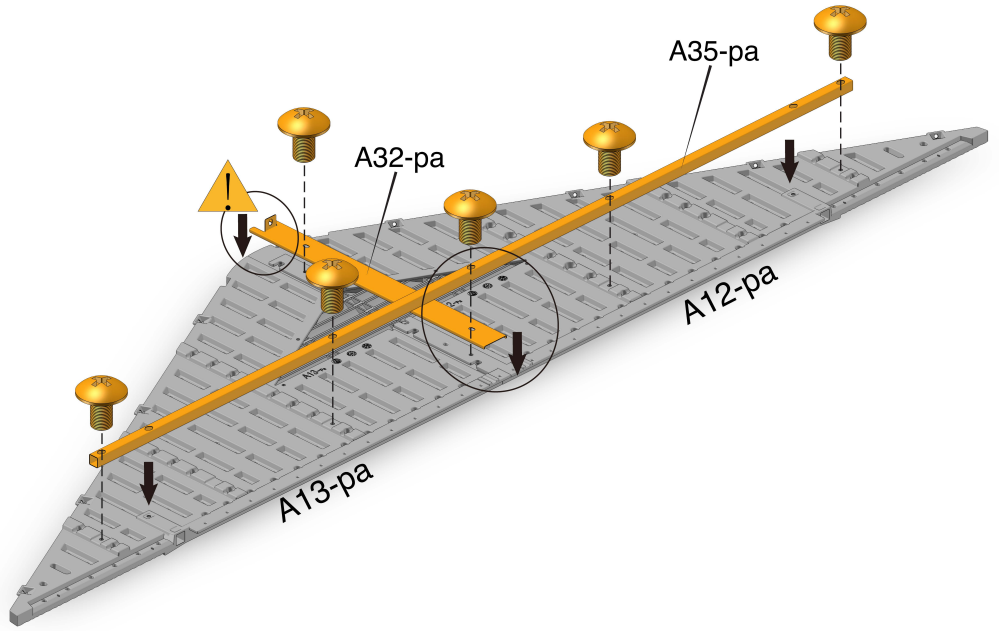
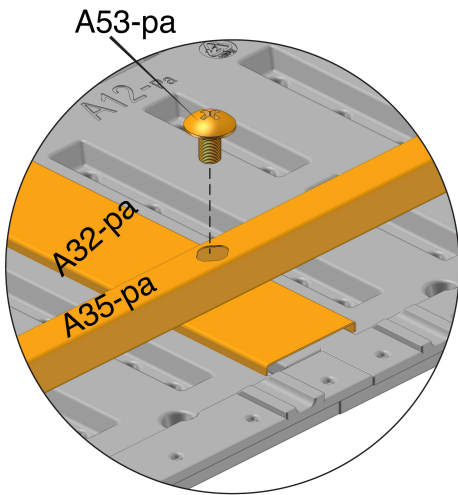
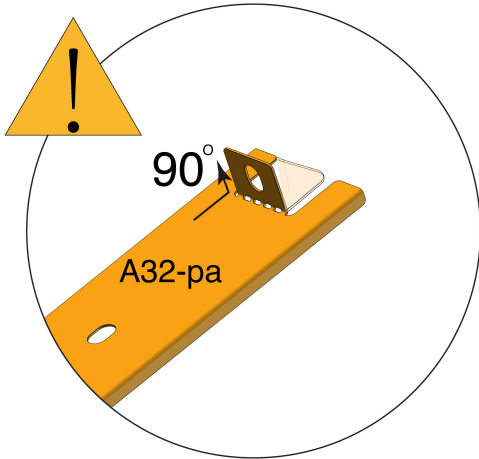
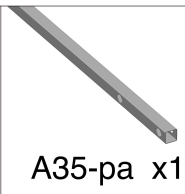
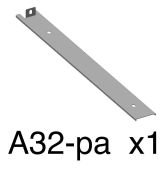

20

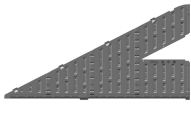

A14-pa x1

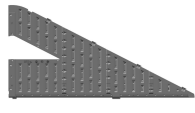

A15-pa x1



A24-pa x1



A54-pa x3



A51-pa x6

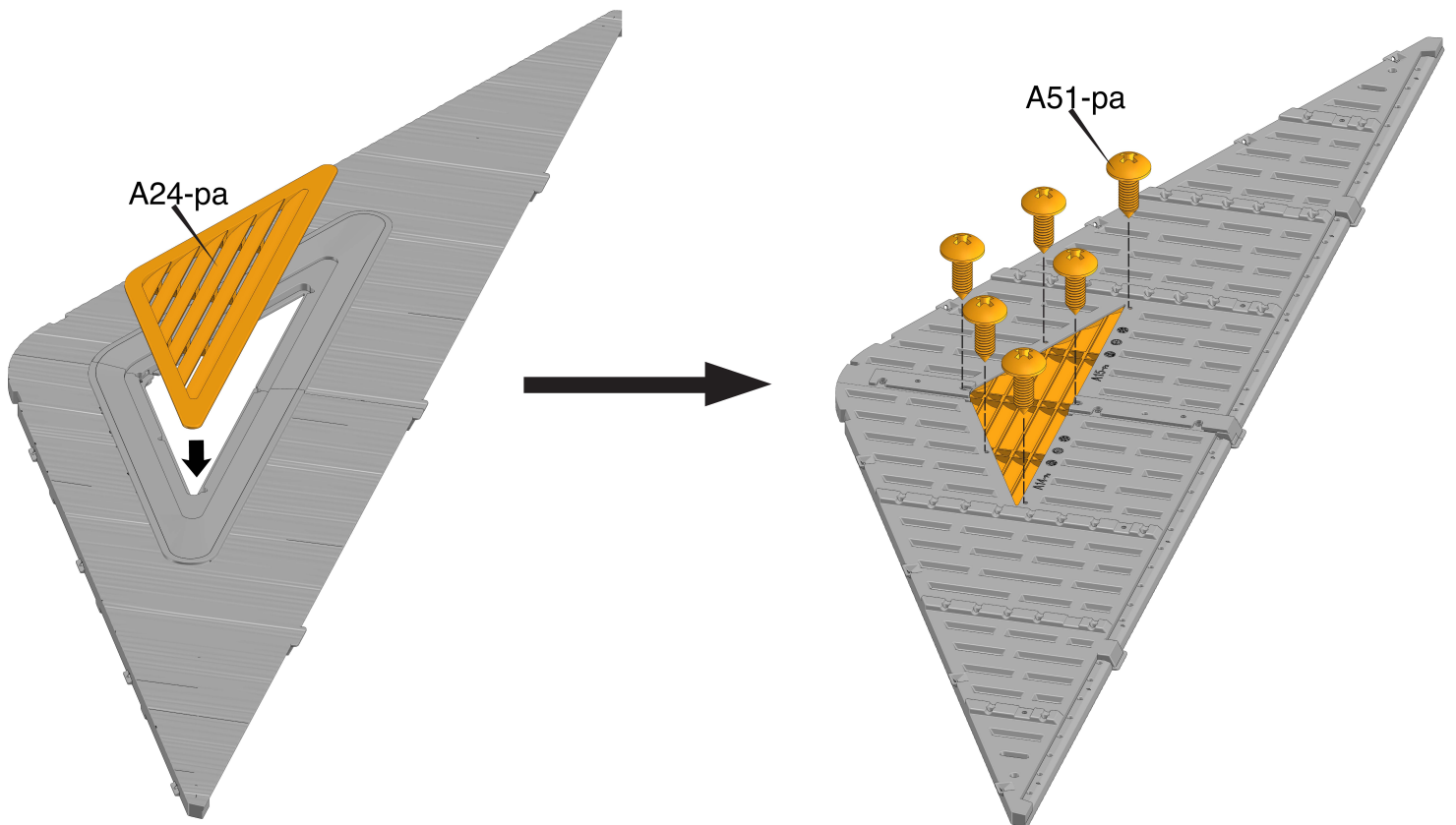
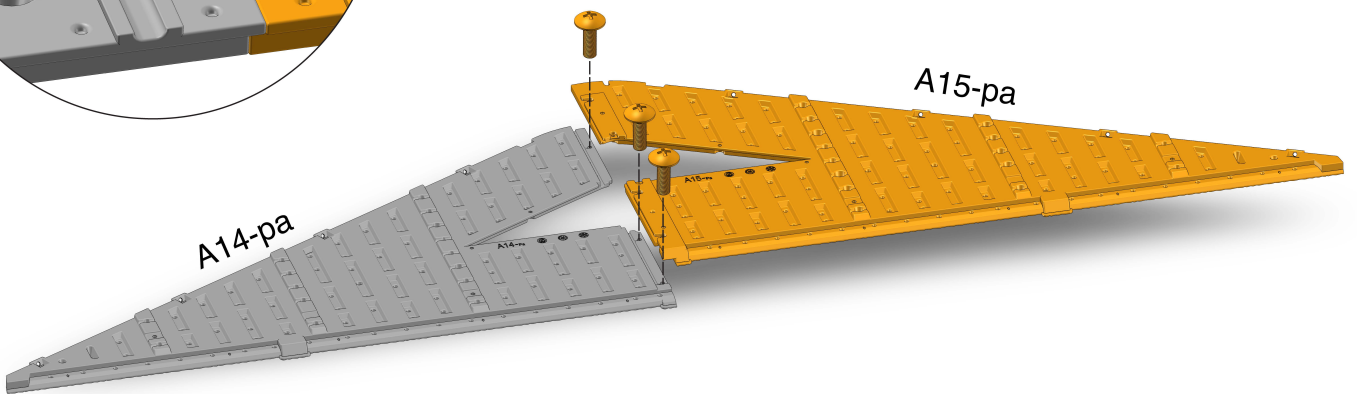
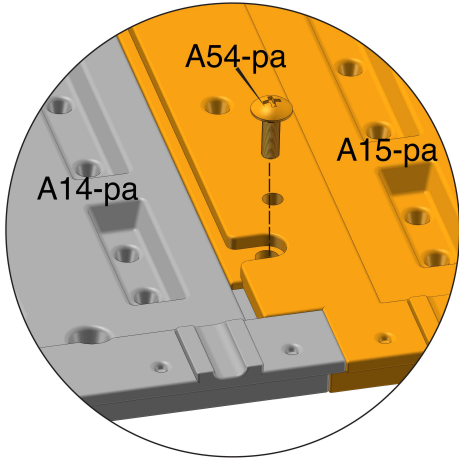

21

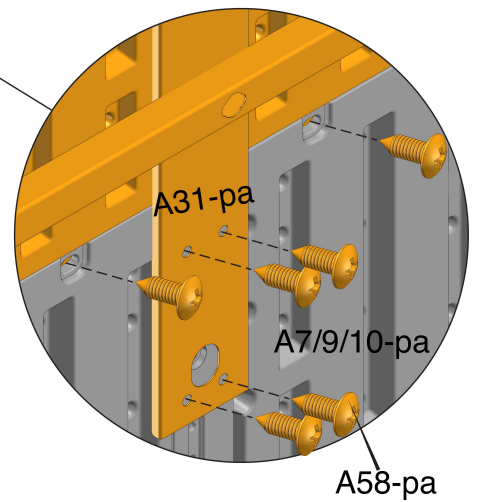
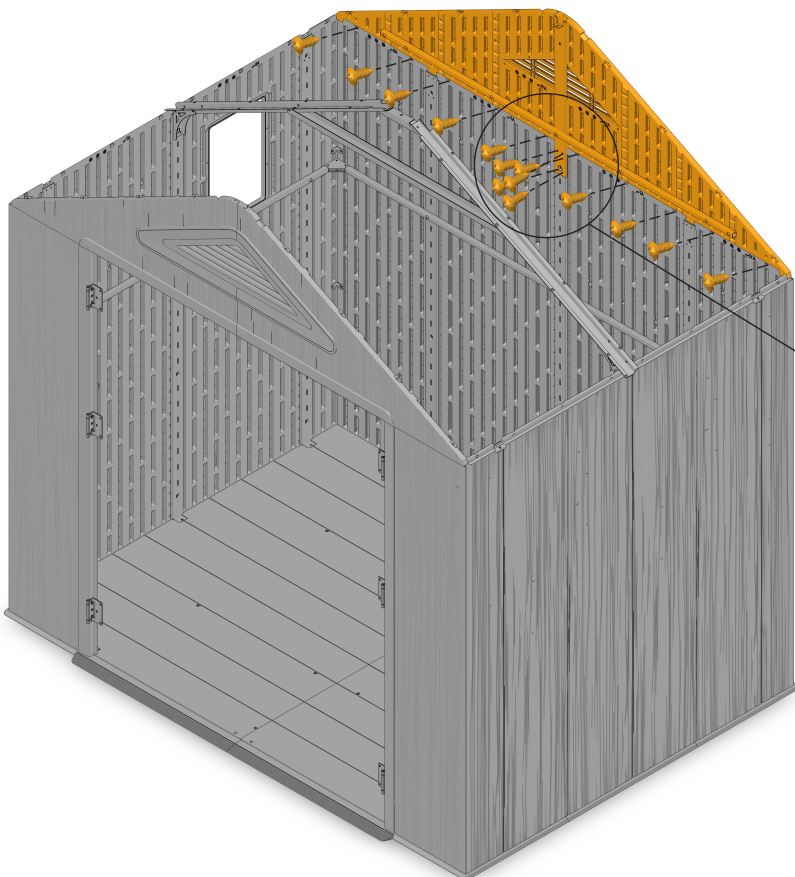
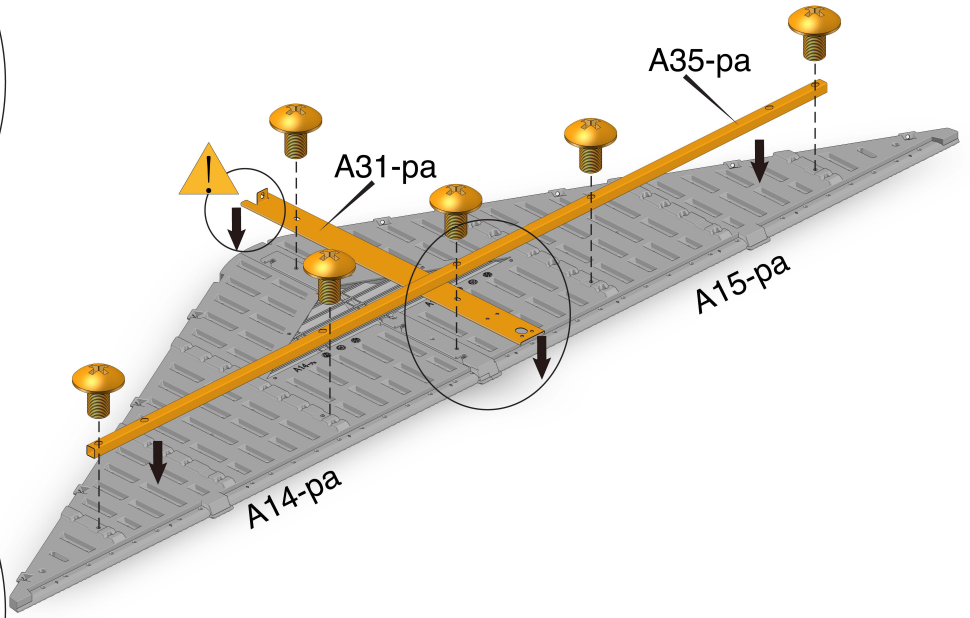
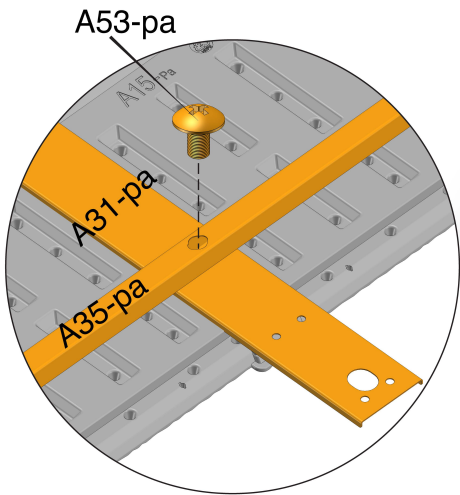
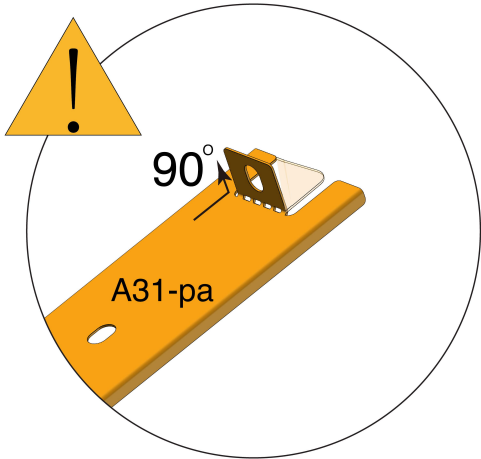
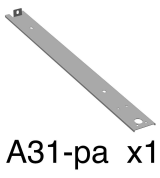

22

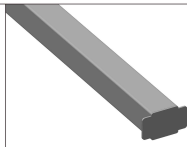

A36-pa x1



A56-pa x1



A53-pa x2

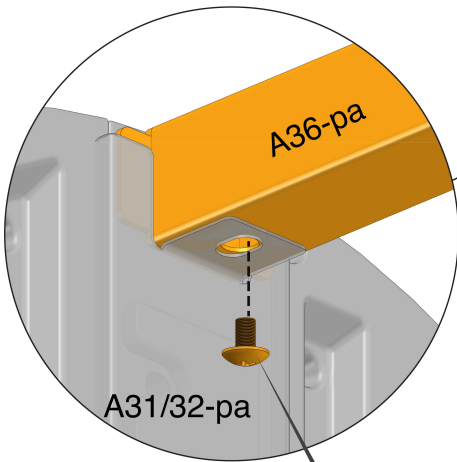

A53-pa

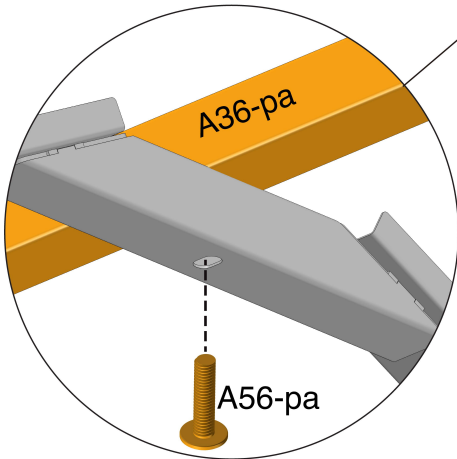

A56-pa

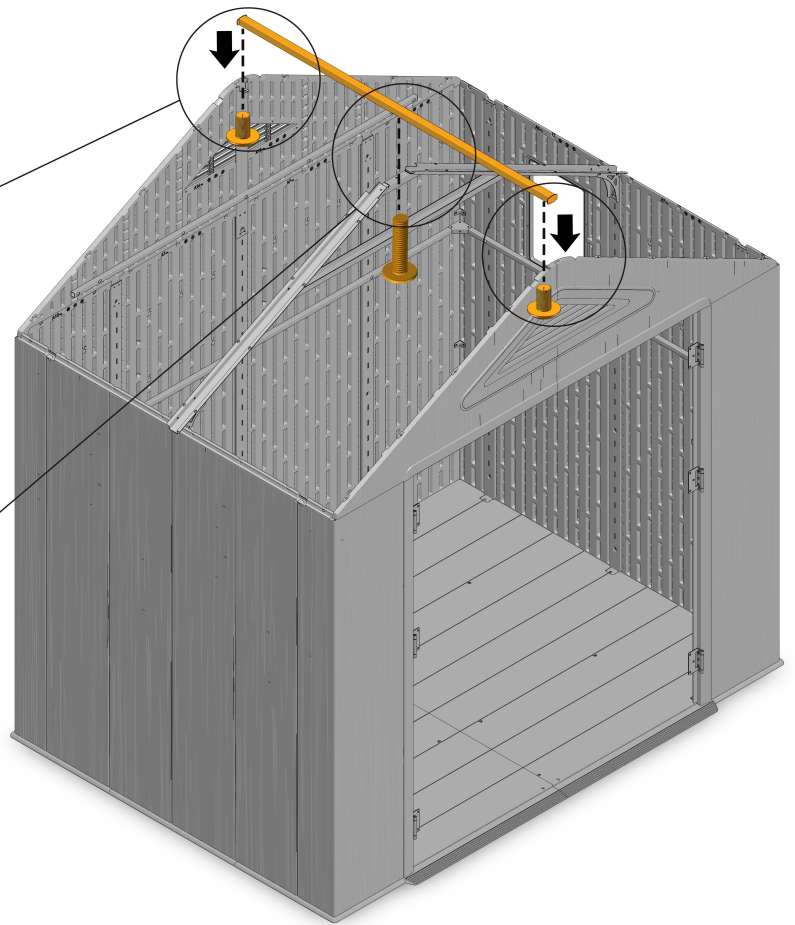

23

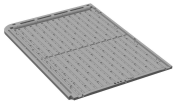

A16-pa x2



A17-pa x2

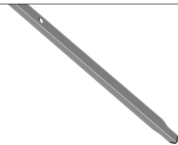

A44-pa x4



A51-pa x8

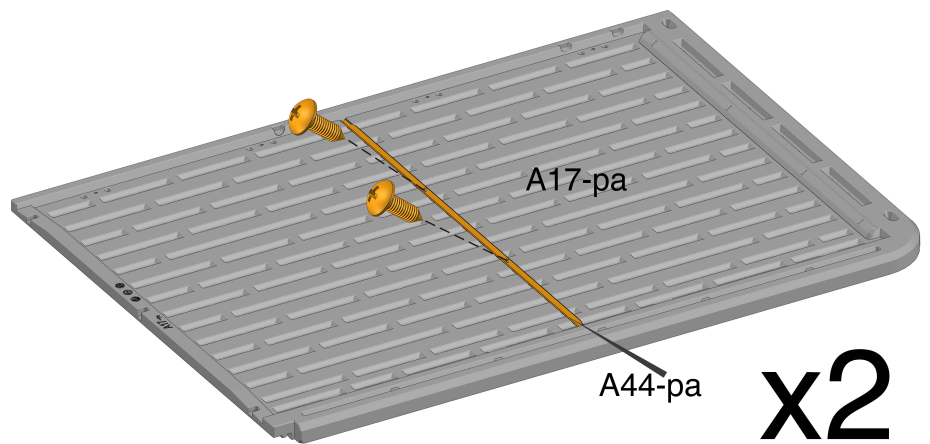
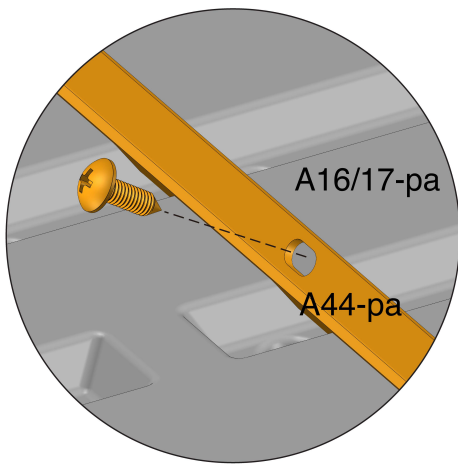
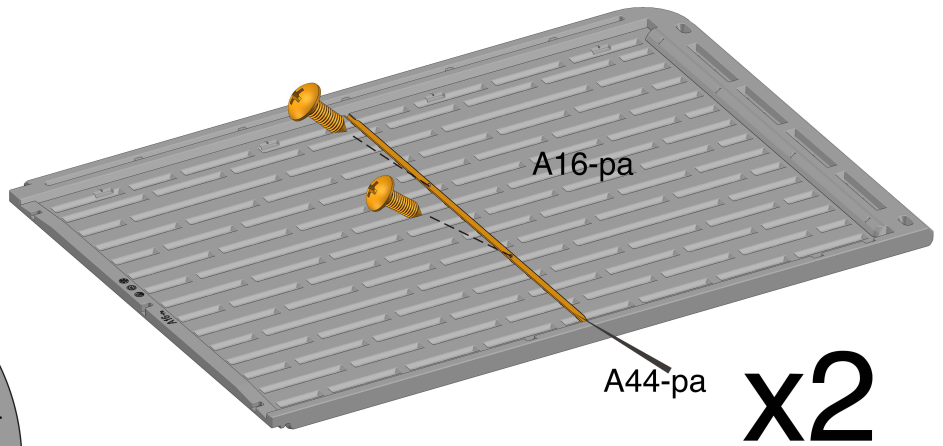
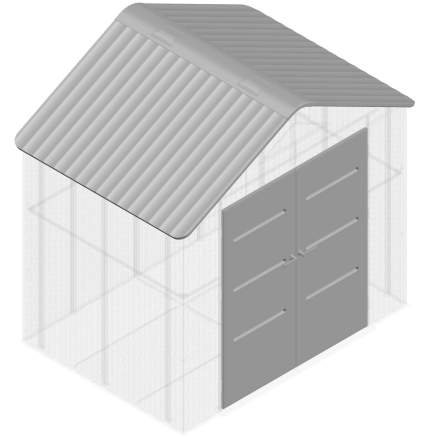
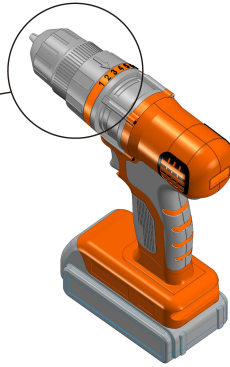
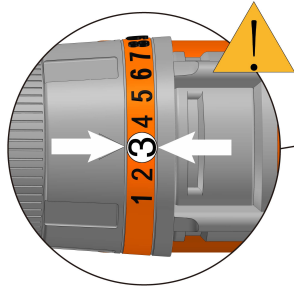

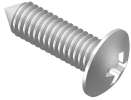
<h1>24</h1>	 A58-pa x8	 A59-pa x16
-------------	--	---

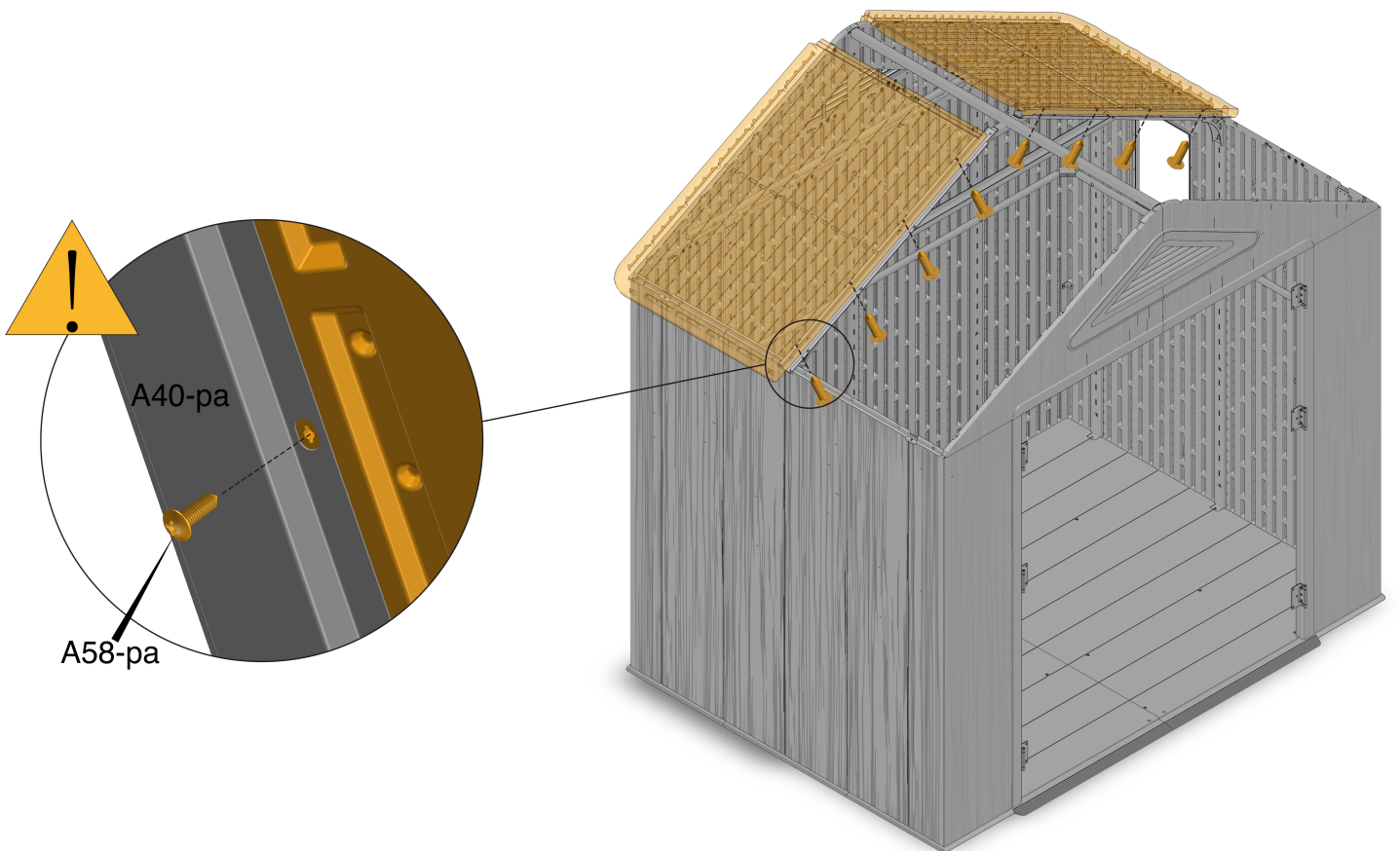
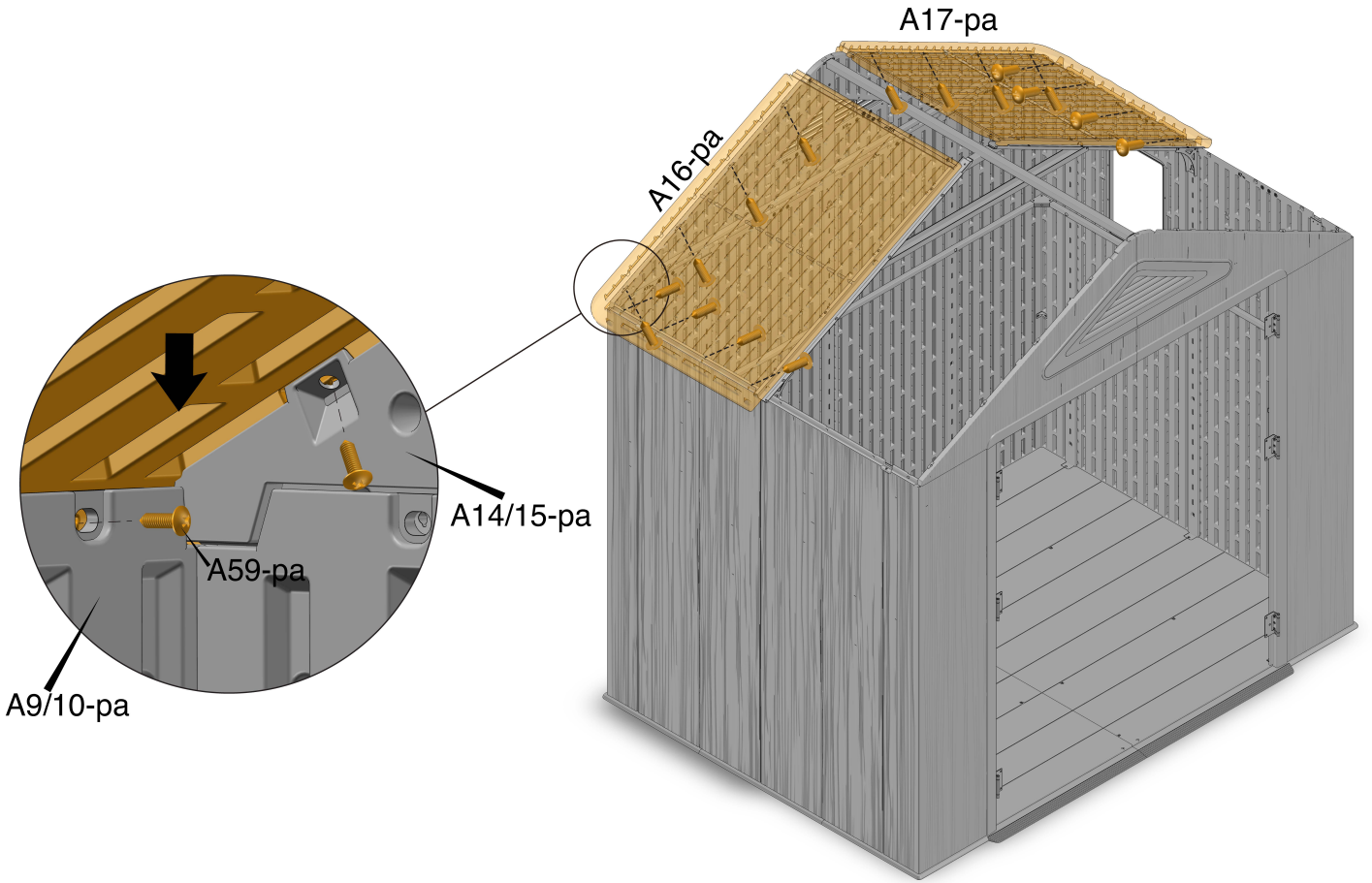

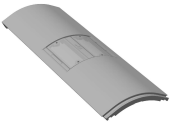
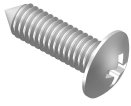
<h1>25</h1>	 <p>A19-pa x1</p>	 <p>A59-pa x22</p>
-------------	---	---

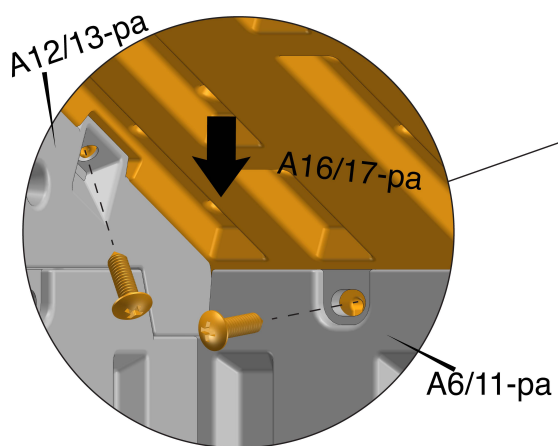
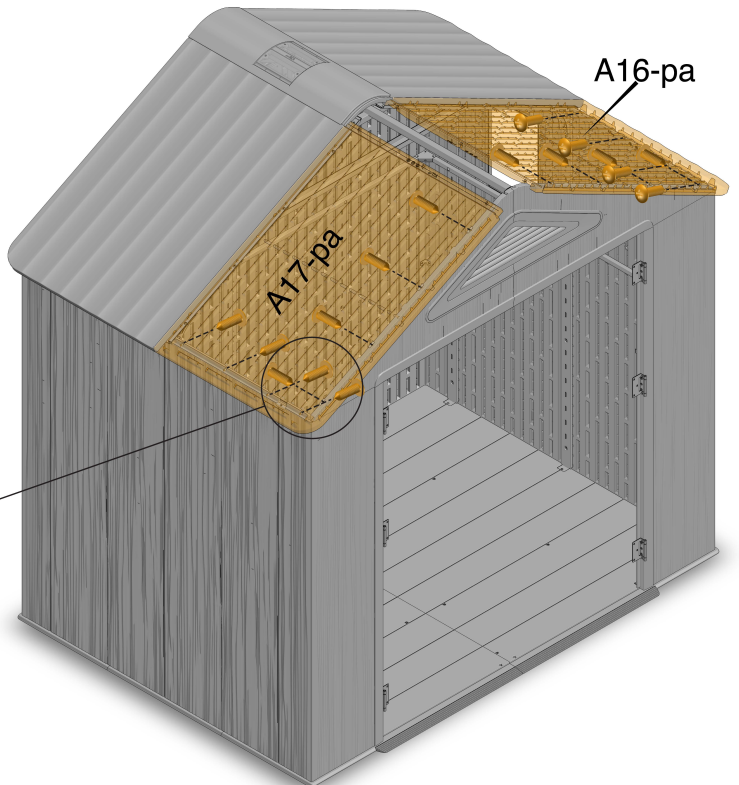
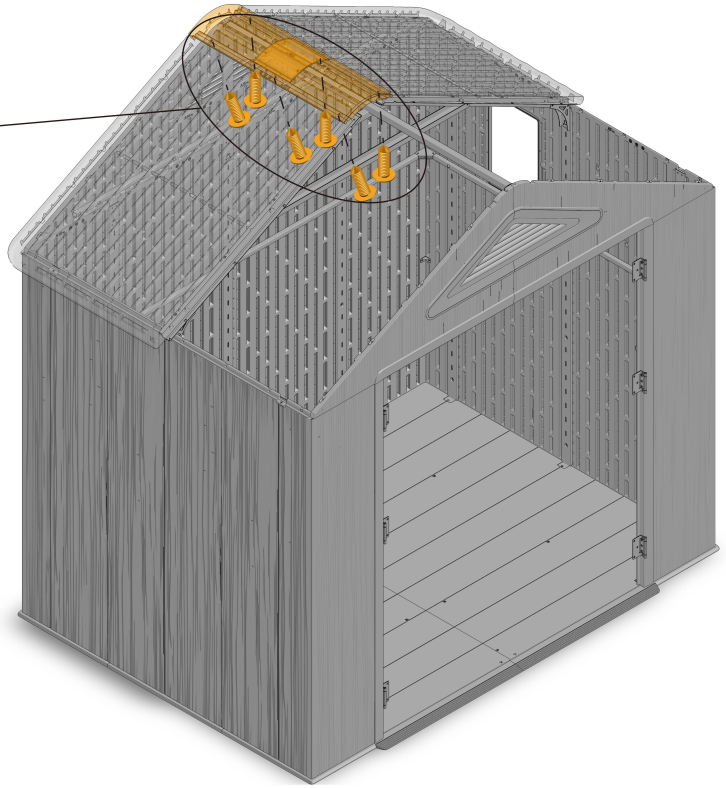
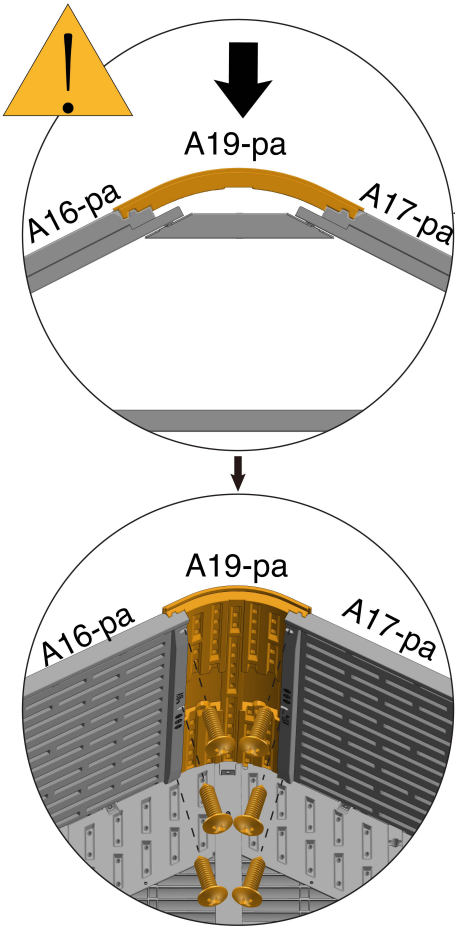

26

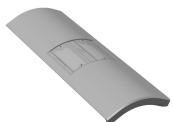

A20-pa x1



A58-pa x8

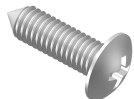

A59-pa x6

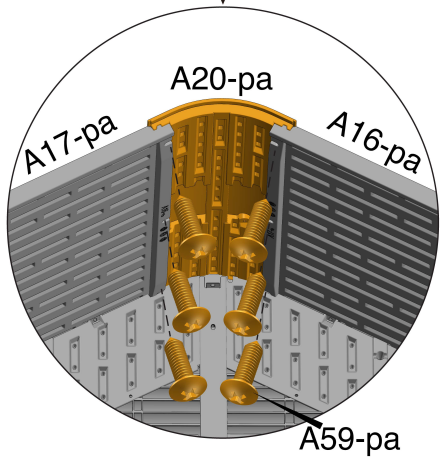
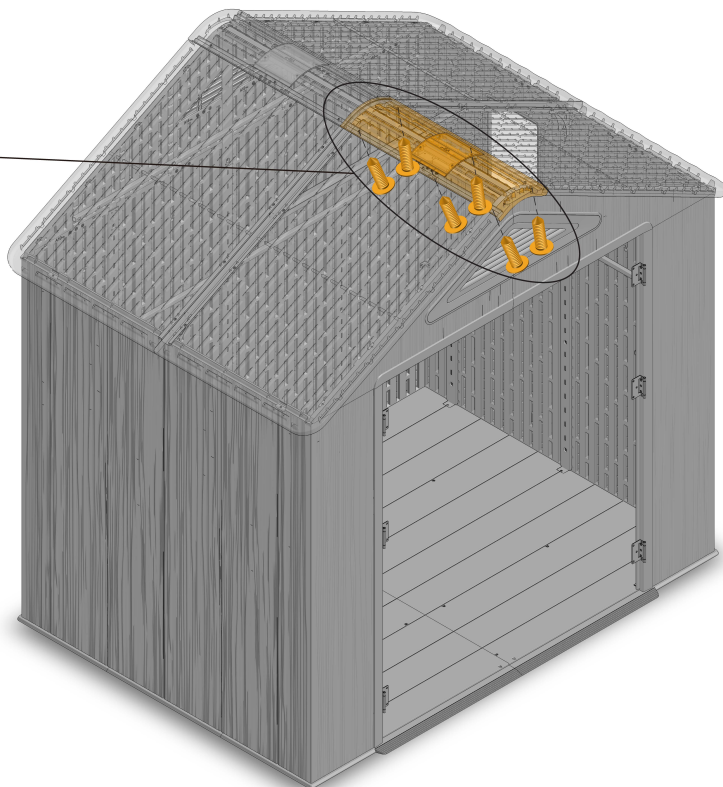
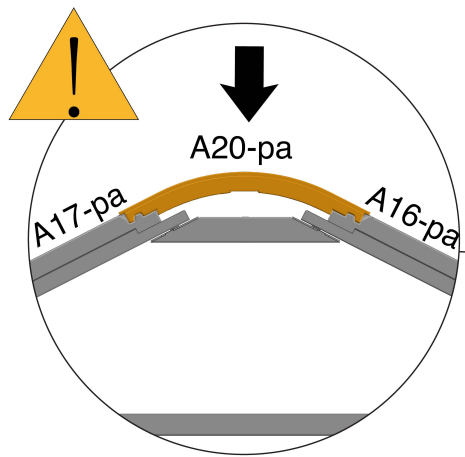
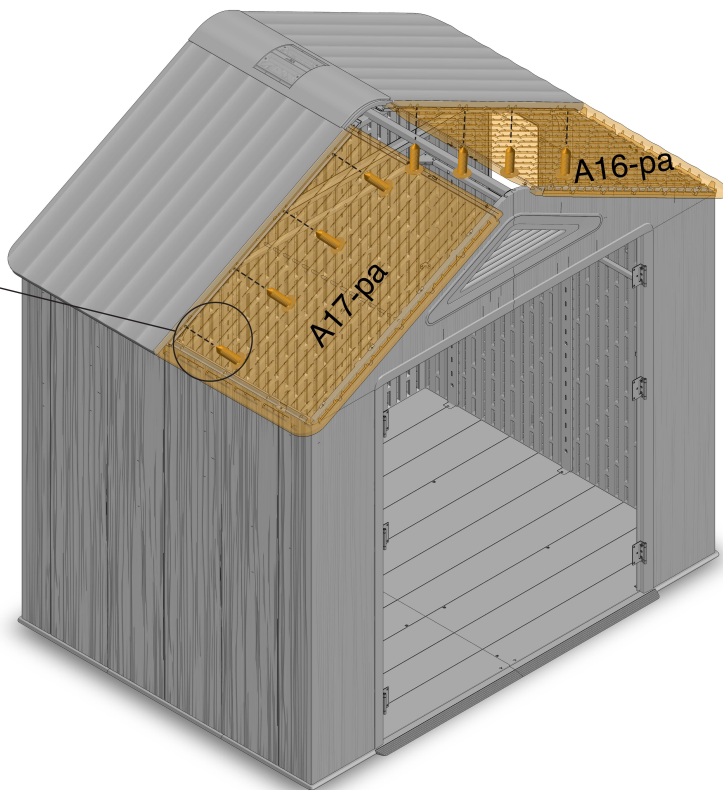
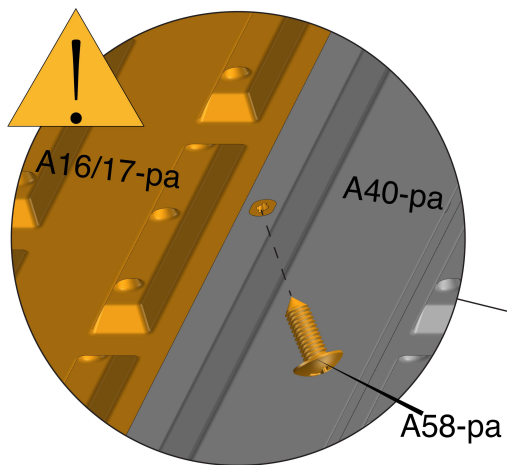

27

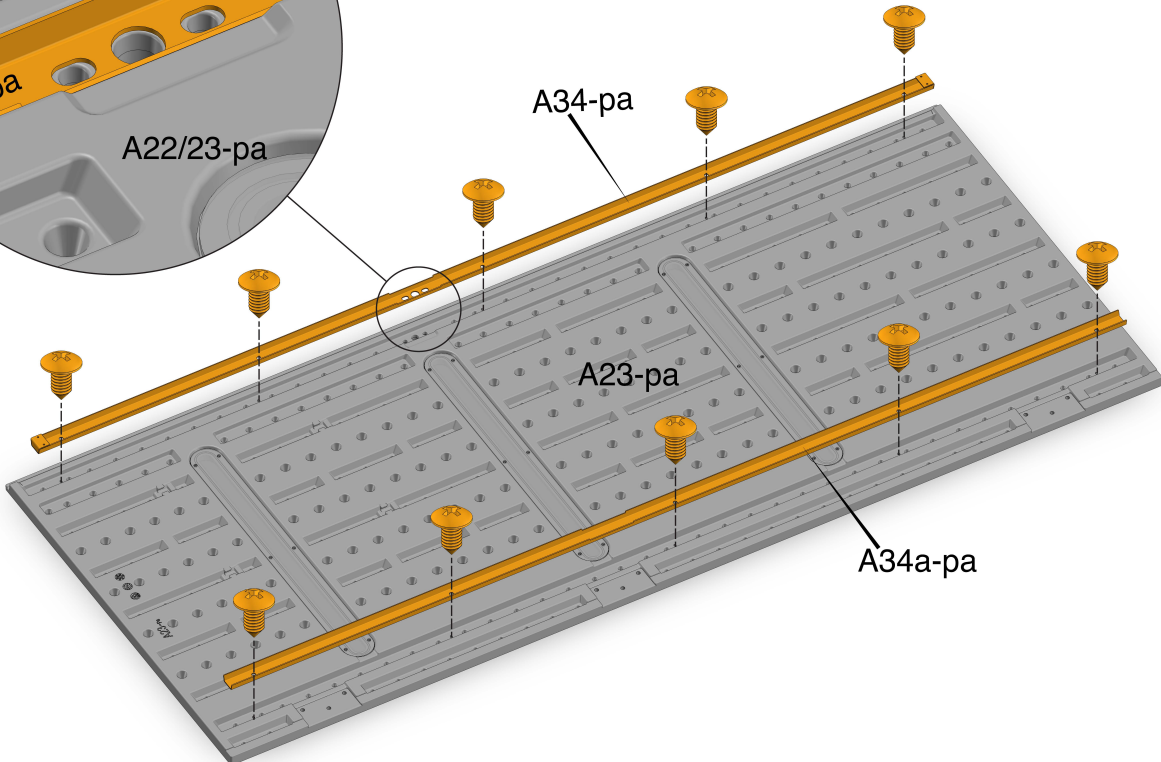
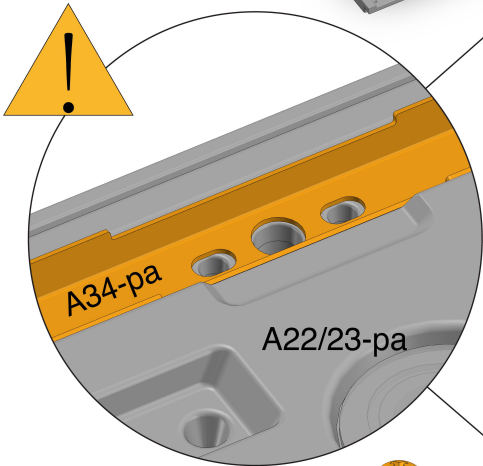
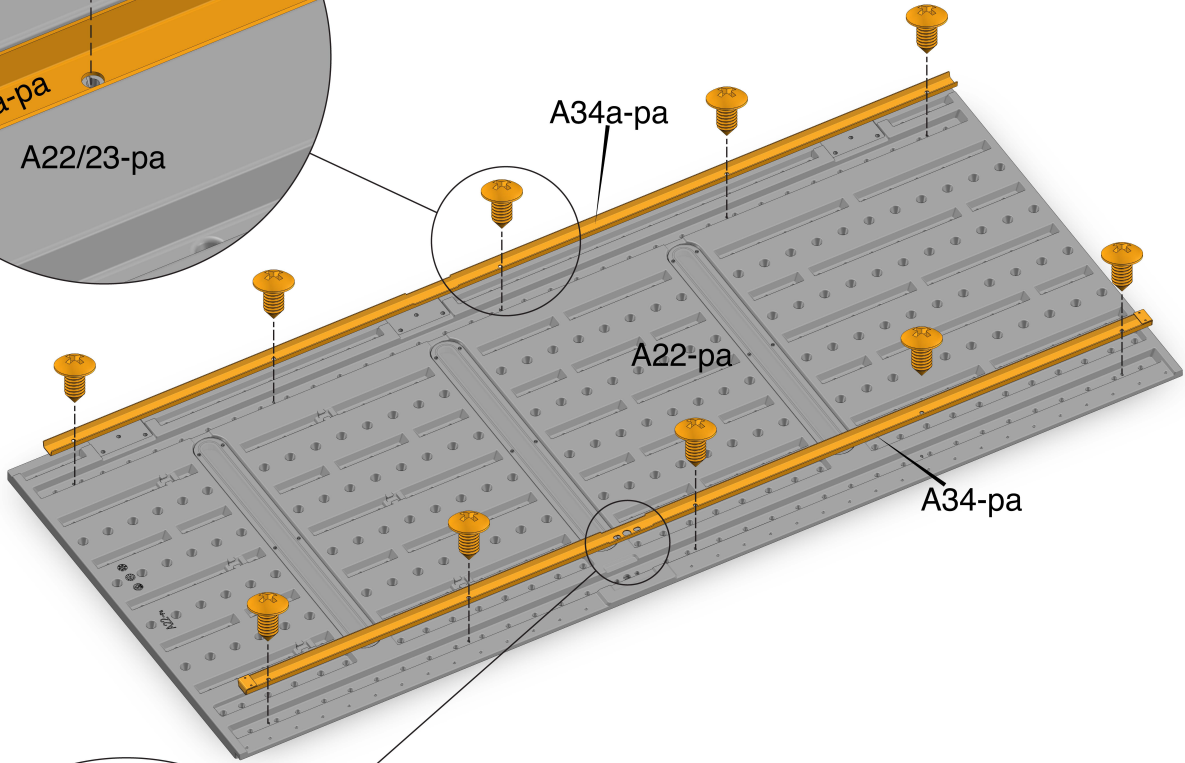
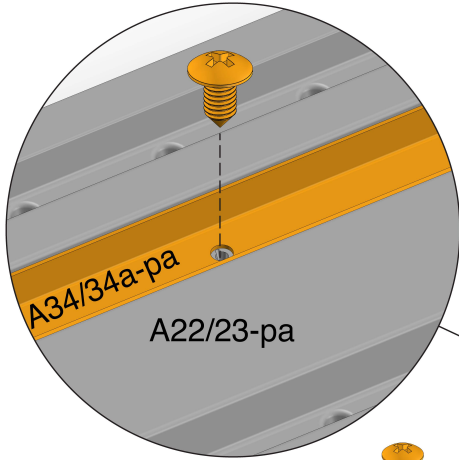
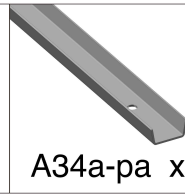
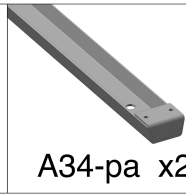
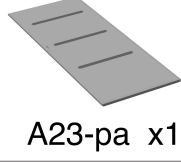
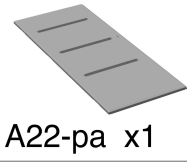

28

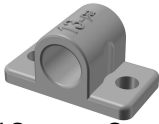

13-pa x2

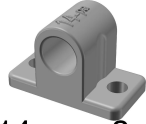

14-pa x2



A51-pa x8

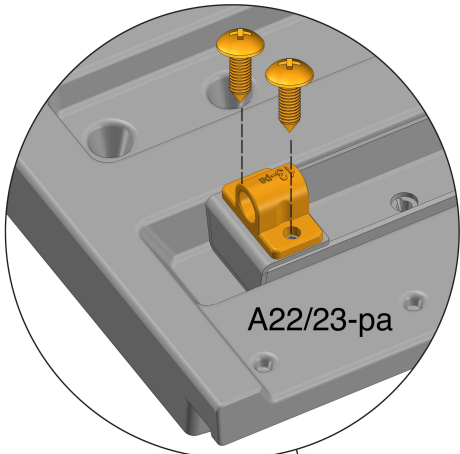

A22/23-pa

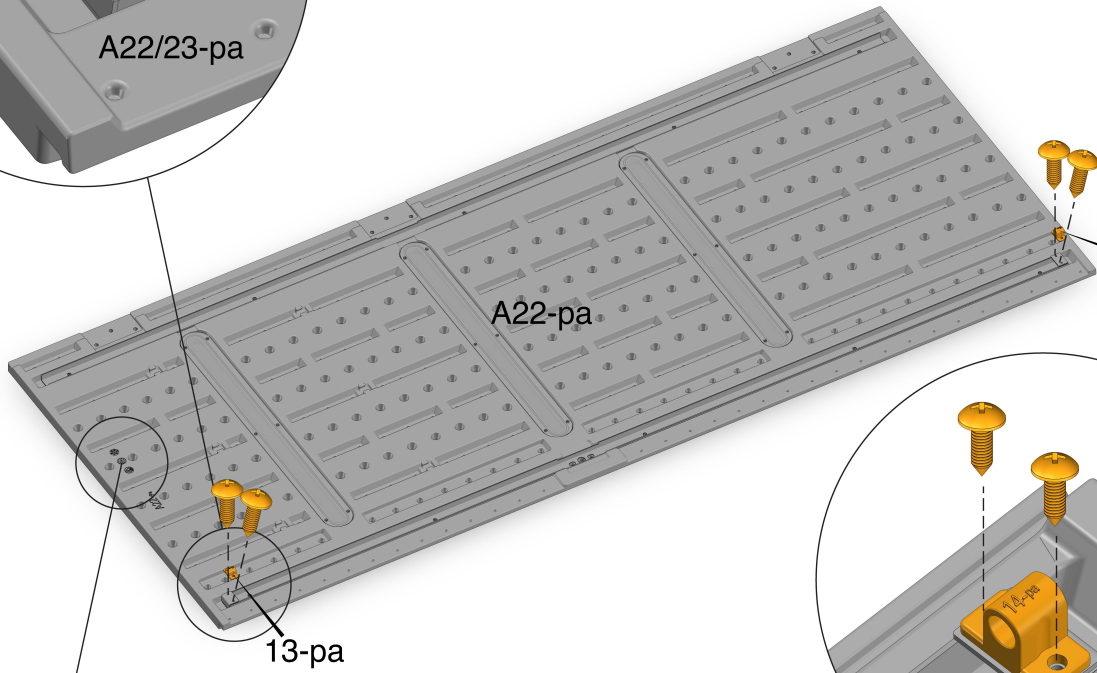

A22-pa

13-pa

14-pa

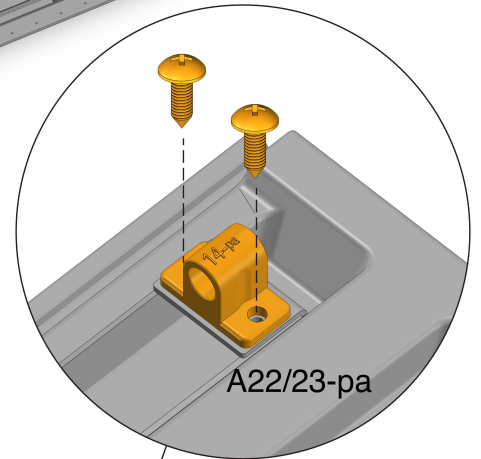

A22/23-pa

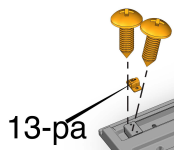
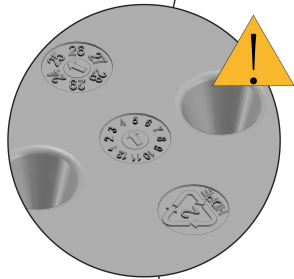

13-pa

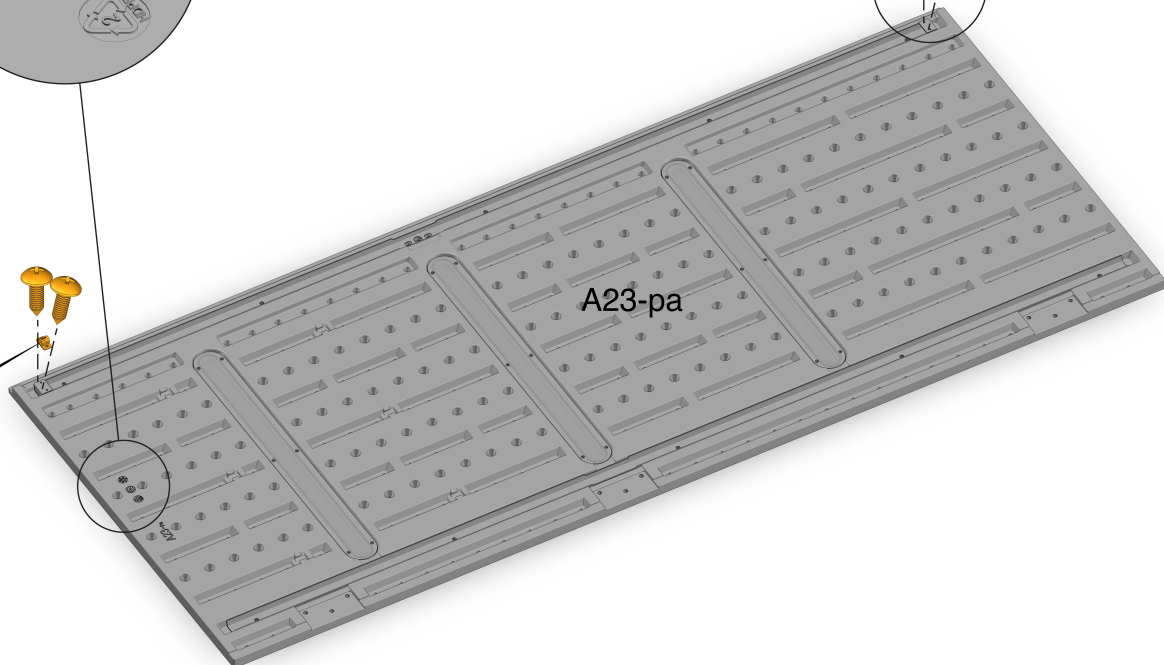

A23-pa

14-pa

29



A53-pa x9

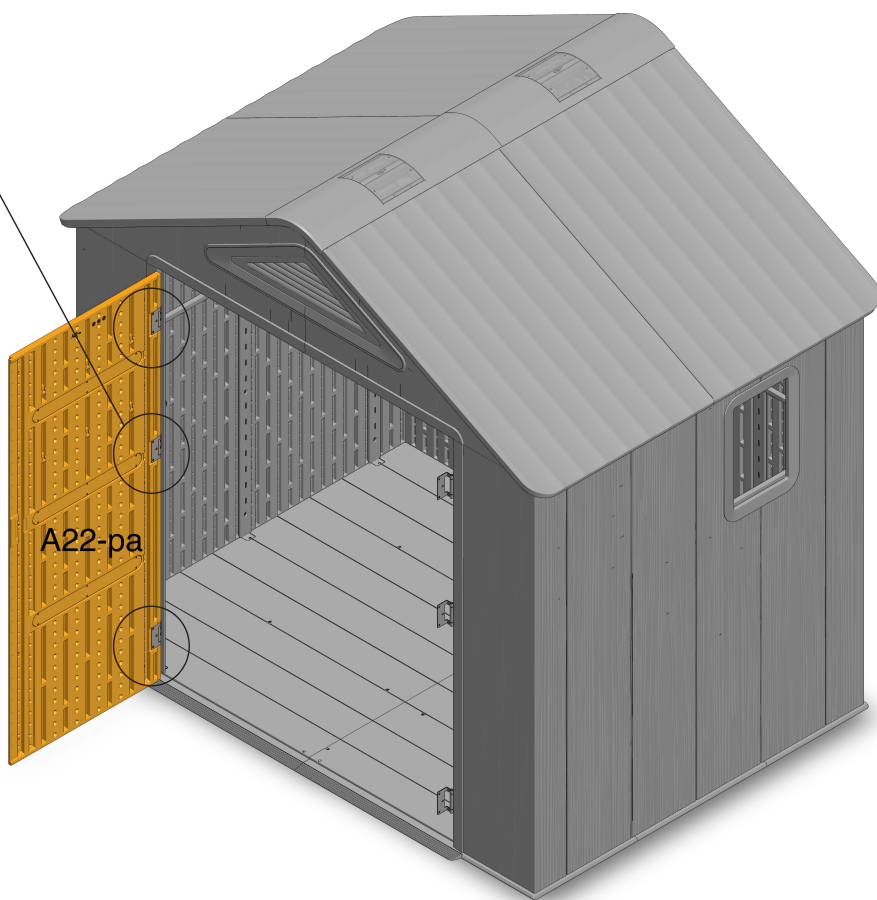
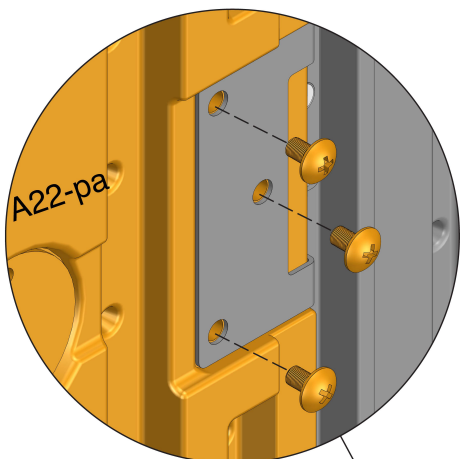

30



1-pa x1

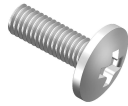

1.1-pa x2



1.2-pa x2

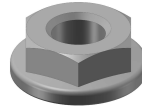

1.3-pa x1

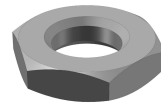

1.4-pa x1



1.5-pa x1



7-pa x1

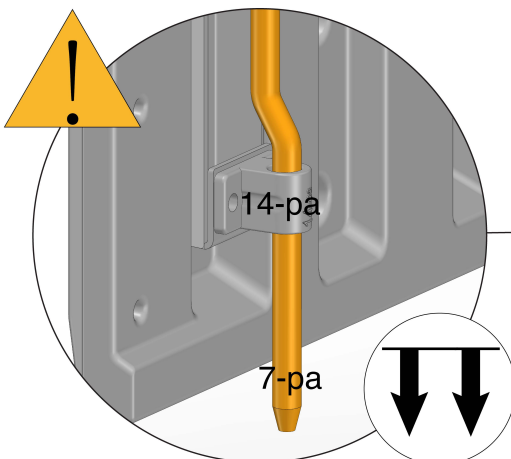
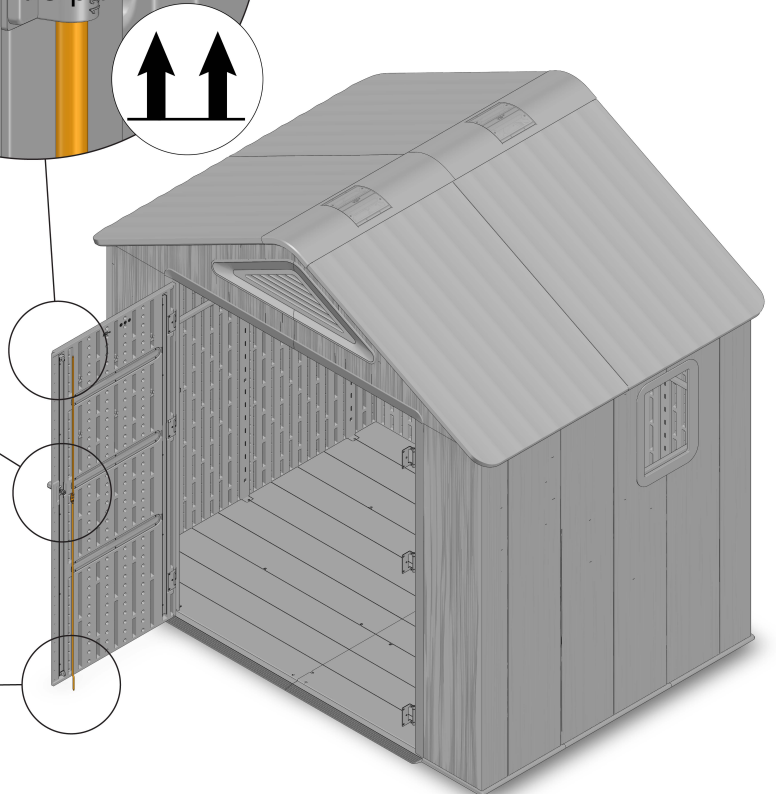
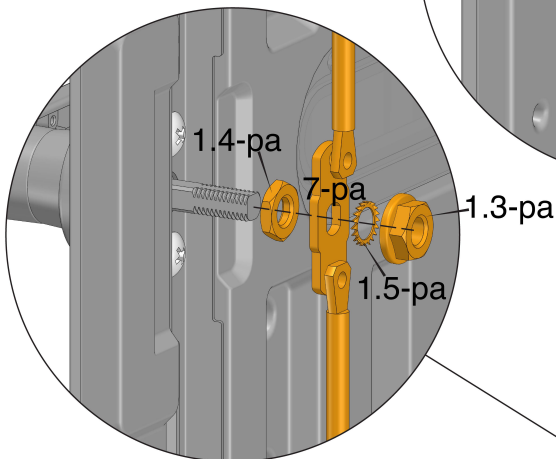
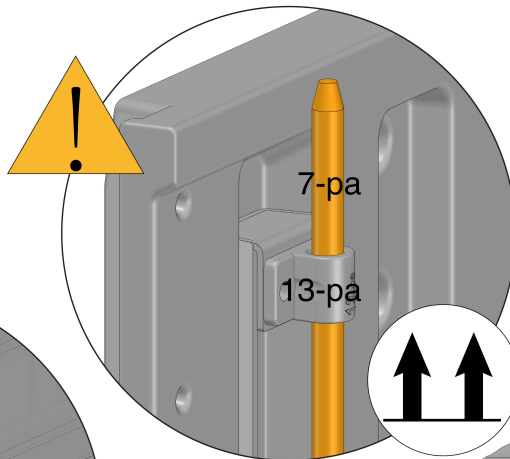
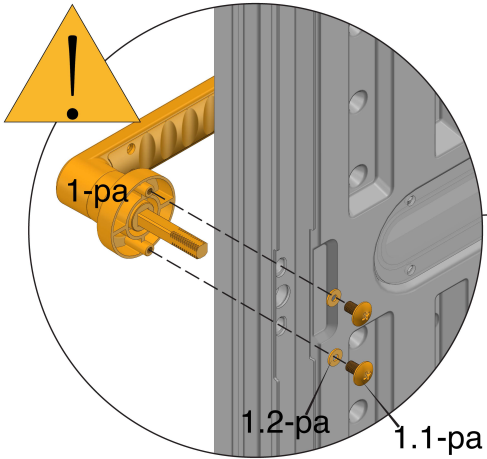
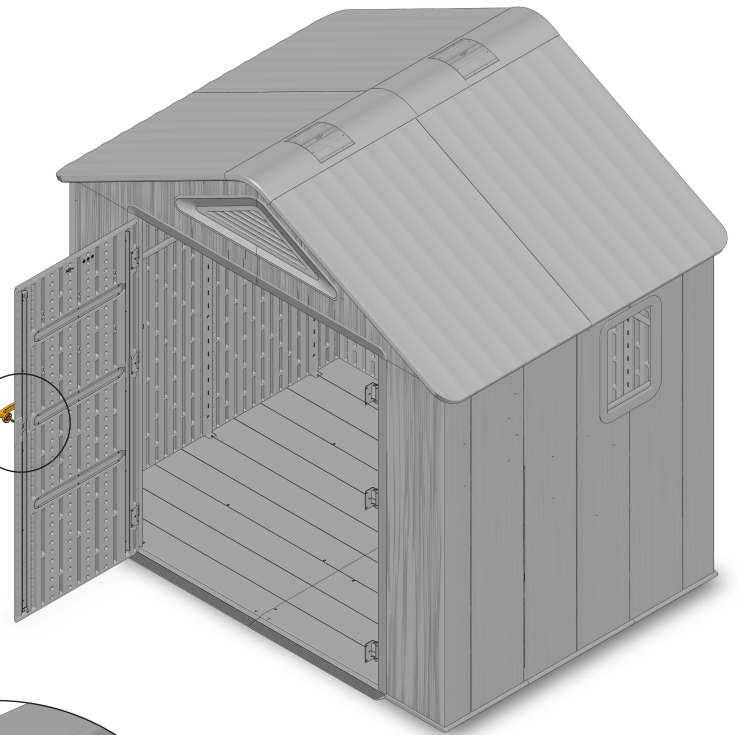

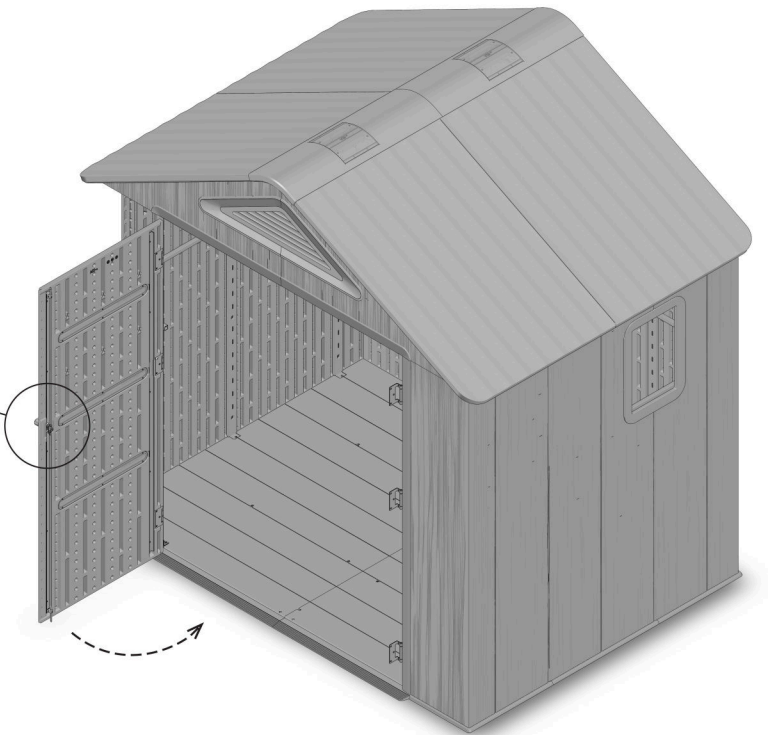
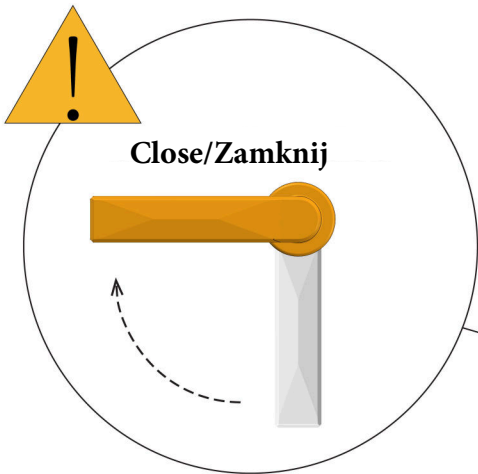
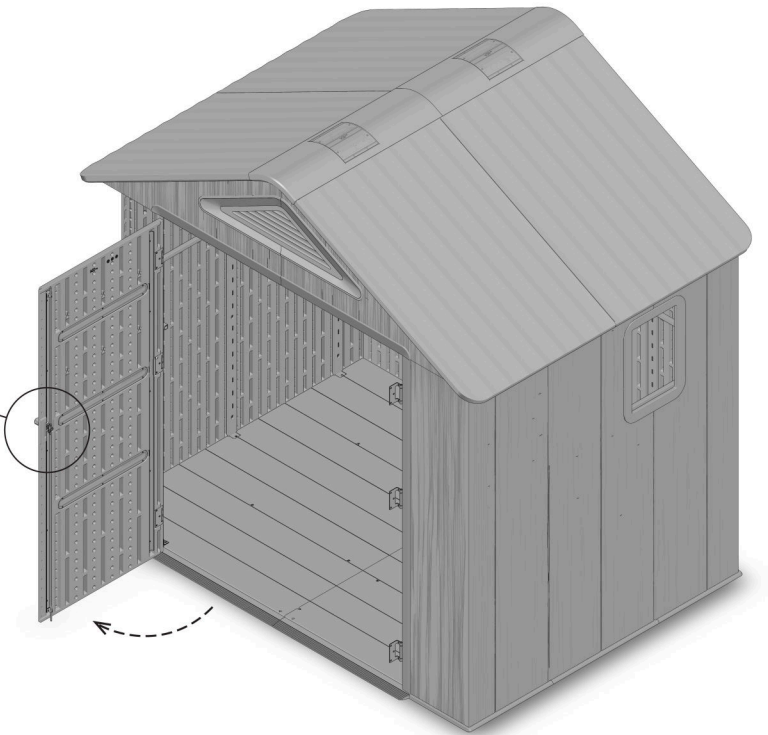
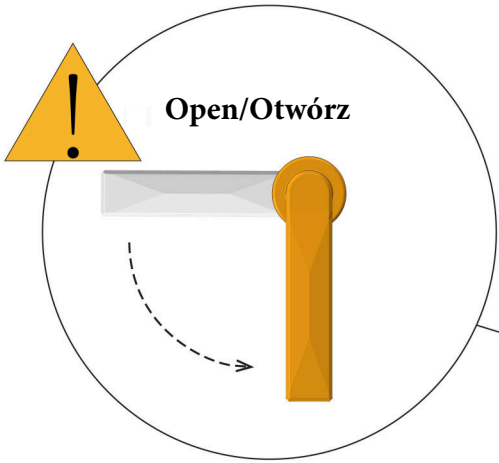

32



A53-pa x9

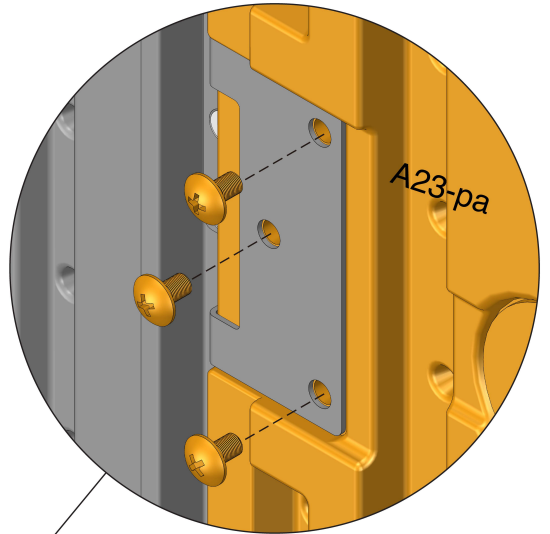
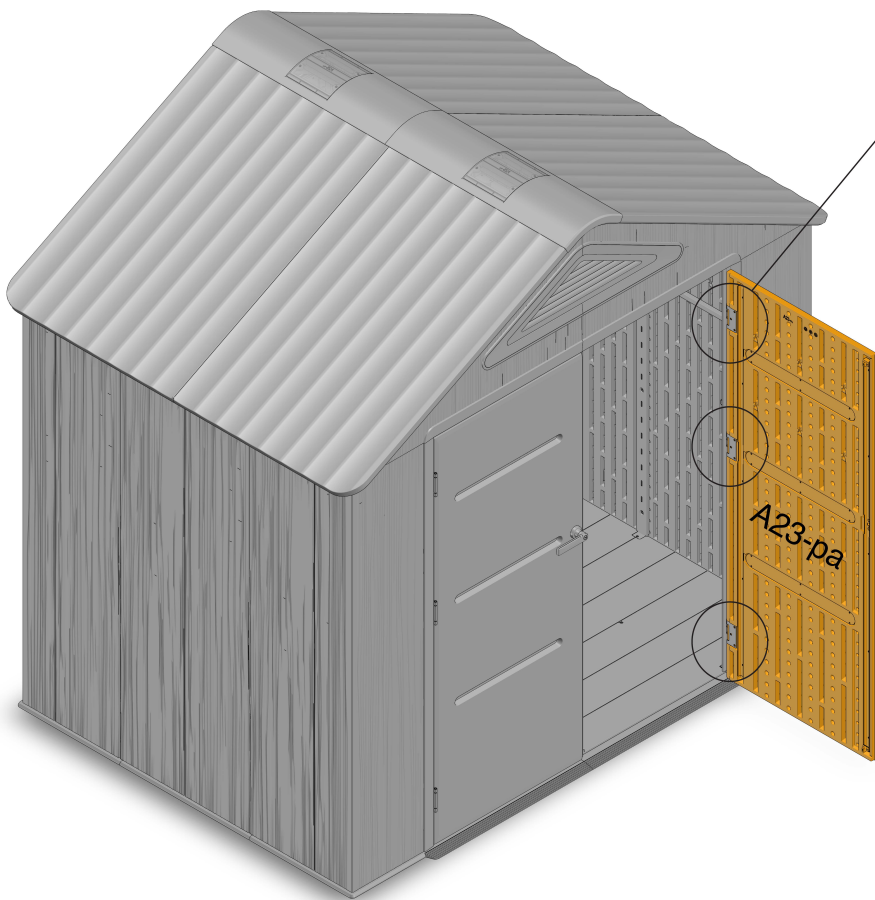

33



2-pa x1

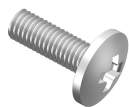

1.1-pa x2



1.2-pa x2

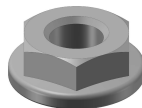

1.3-pa x1

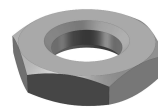

1.4-pa x1



1.5-pa x1

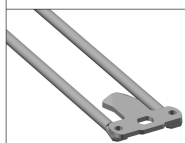

8-pa x1

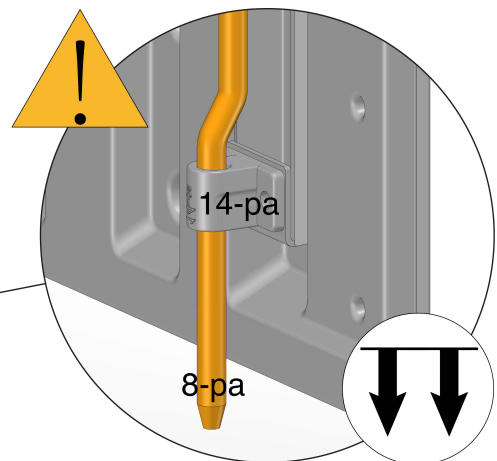
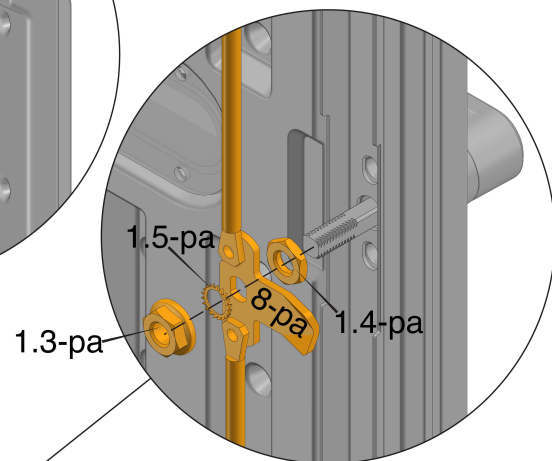
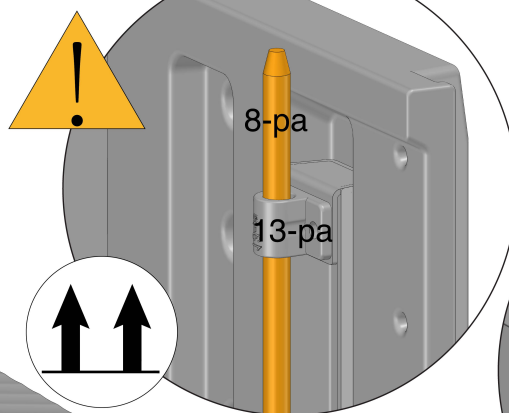
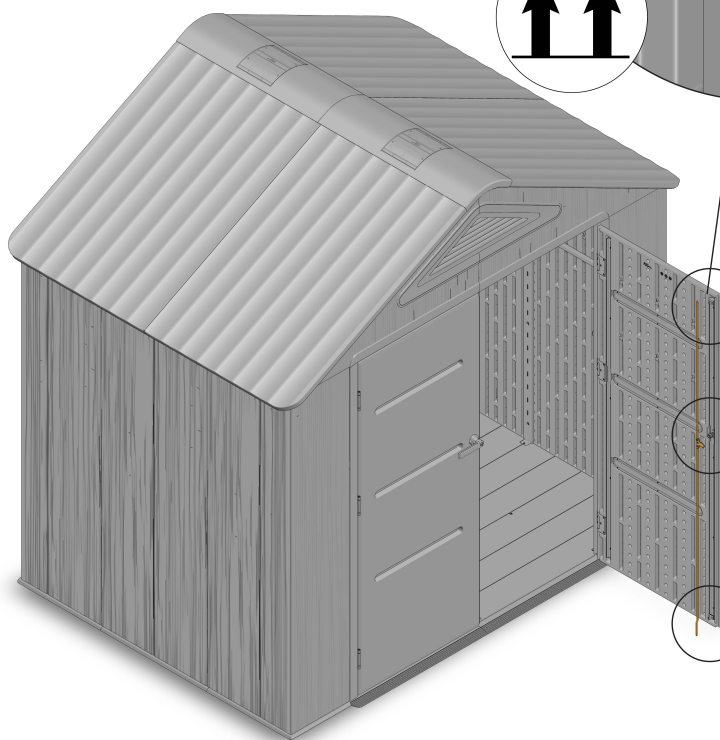
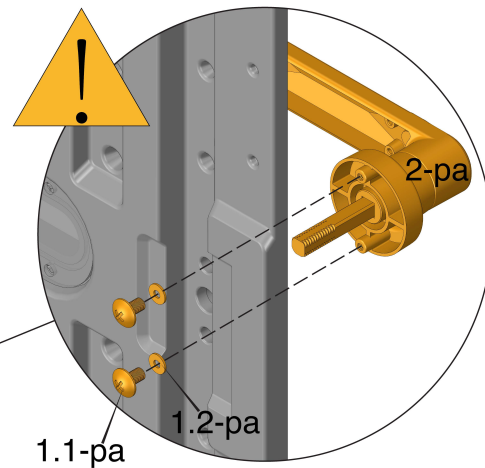
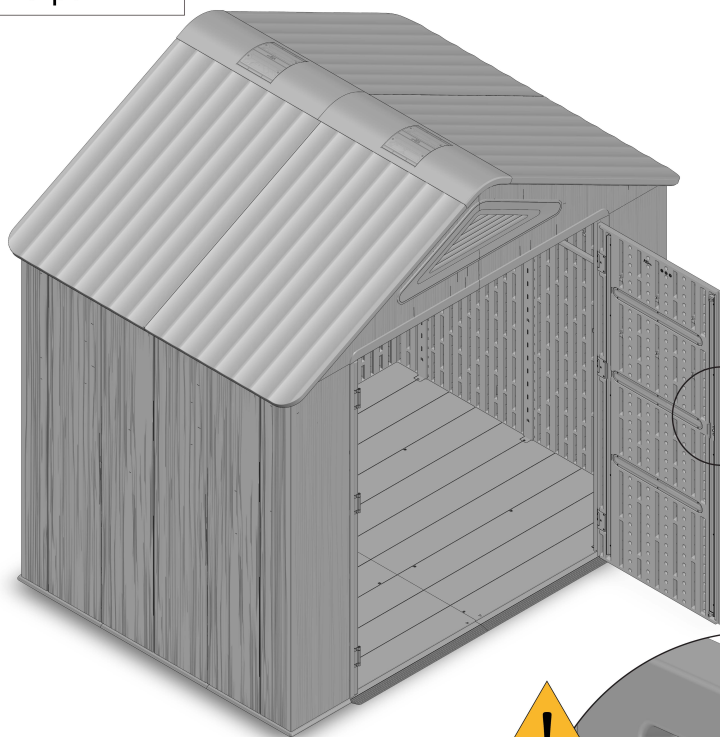

34

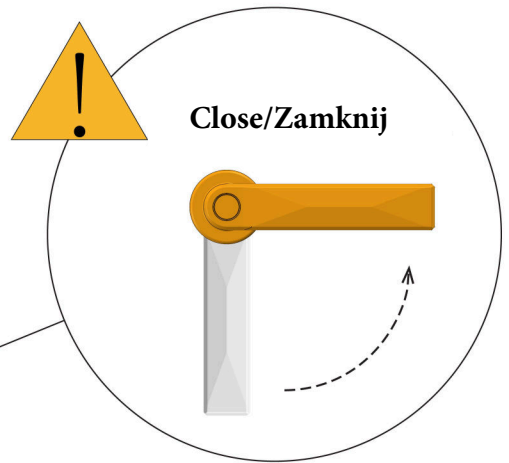
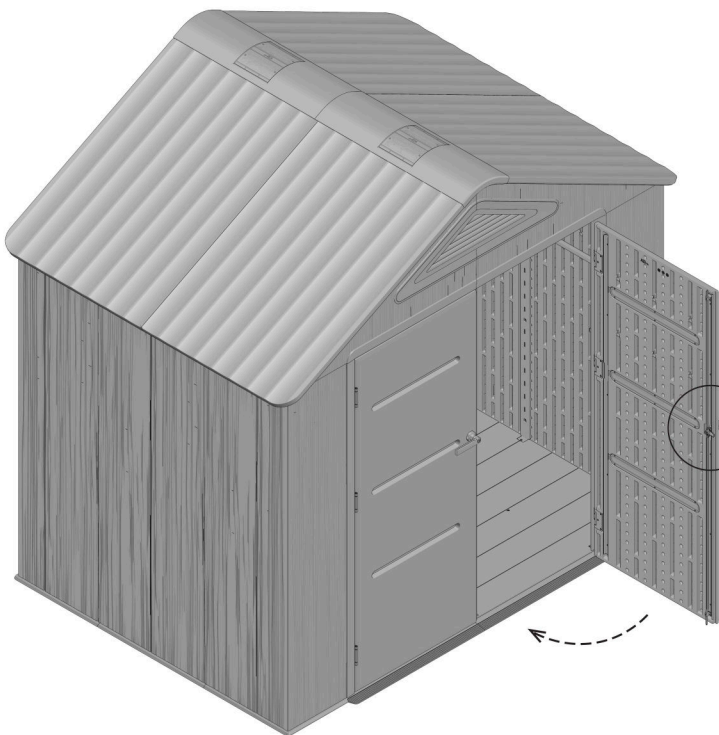
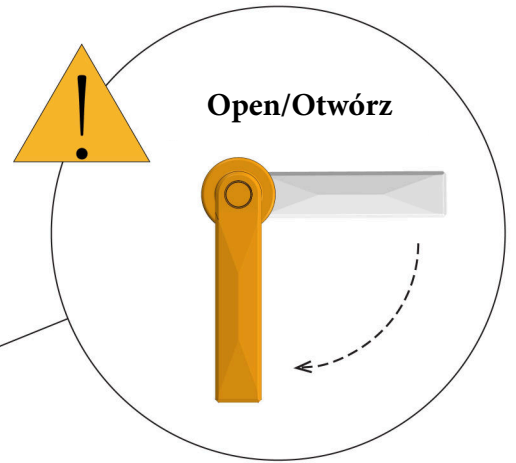
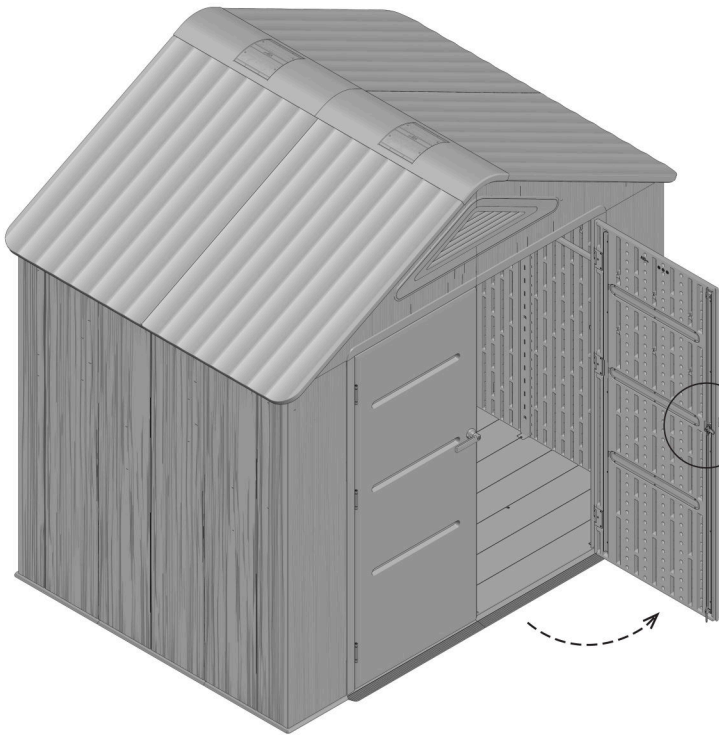

35



11-pa x5

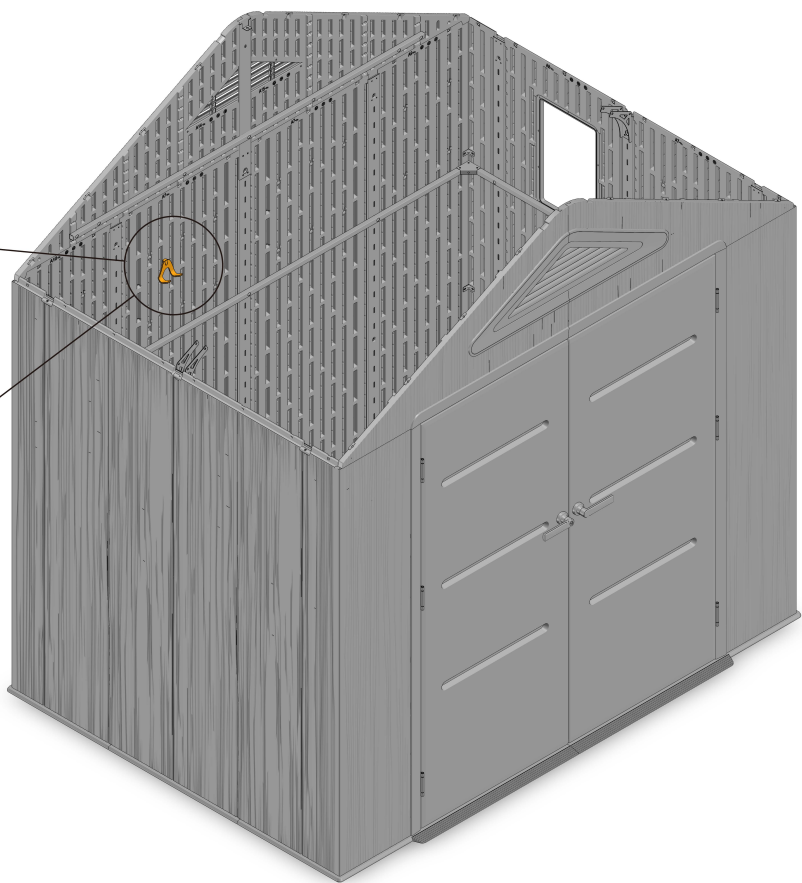
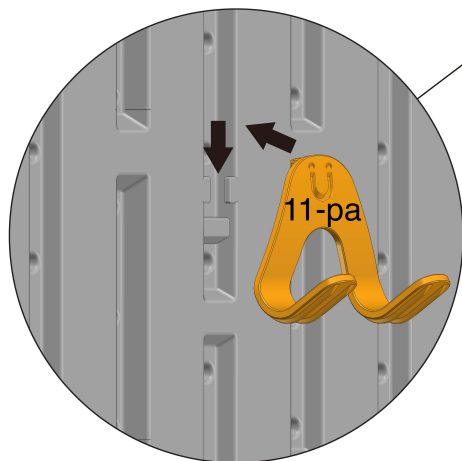
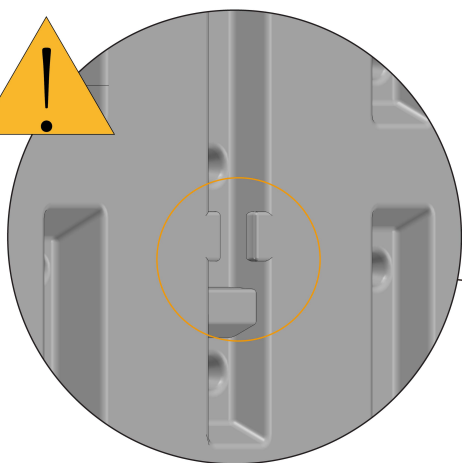
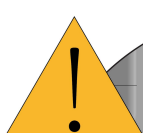

36

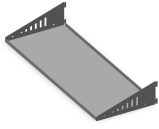

19-pa x2

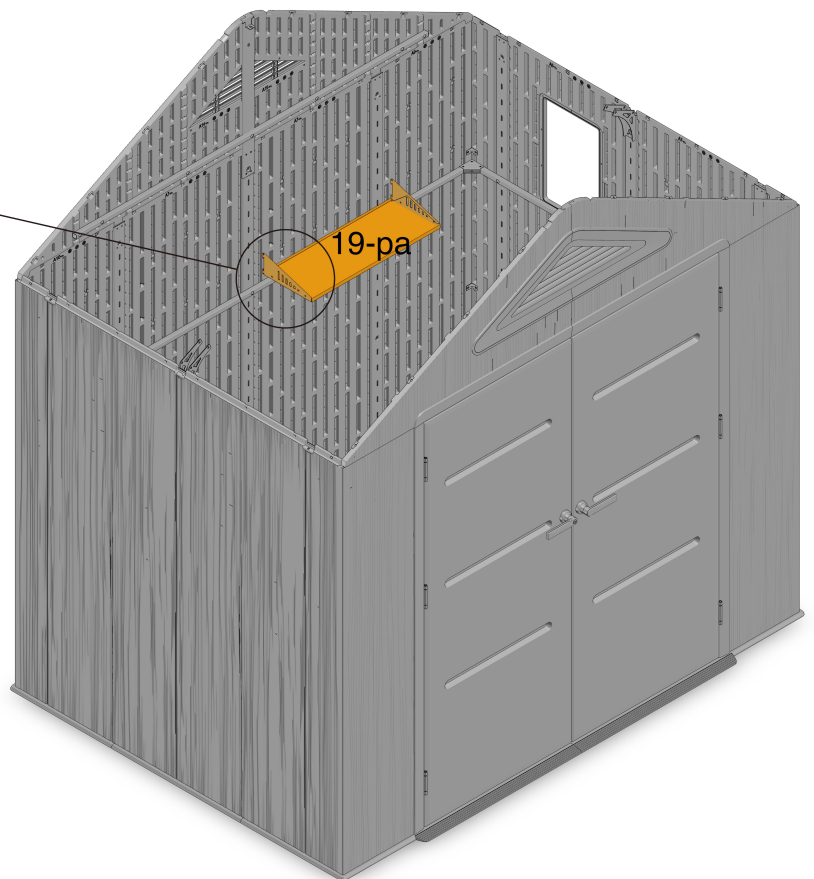
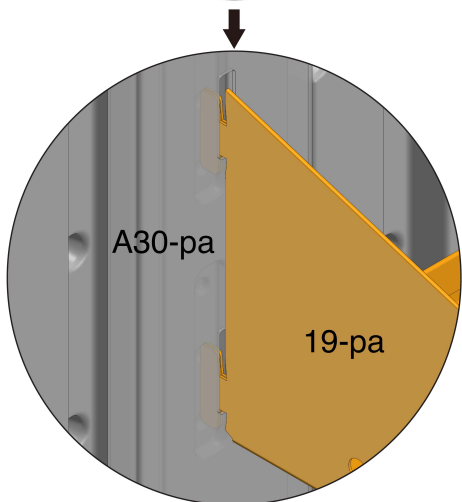
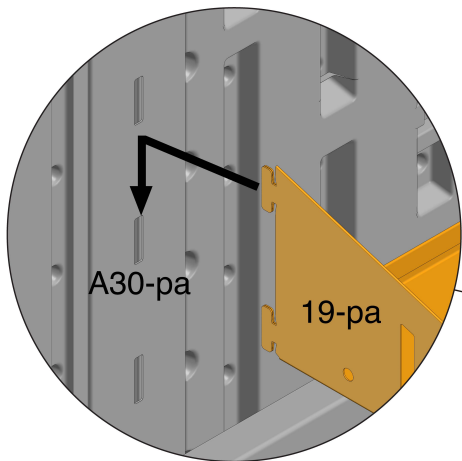
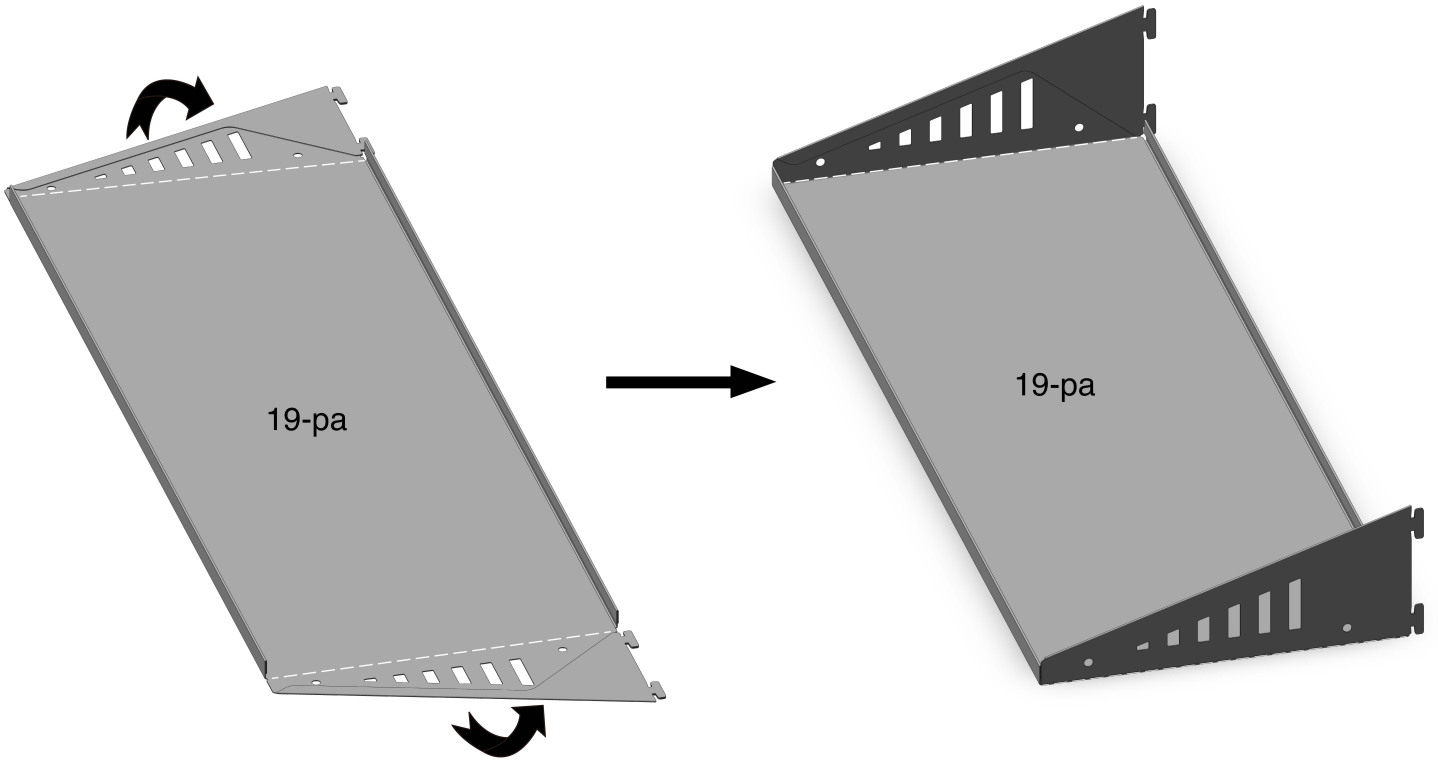

37



A60-pa x11

Montaż na drewnianej podstawie/ Assembly on a wooden base

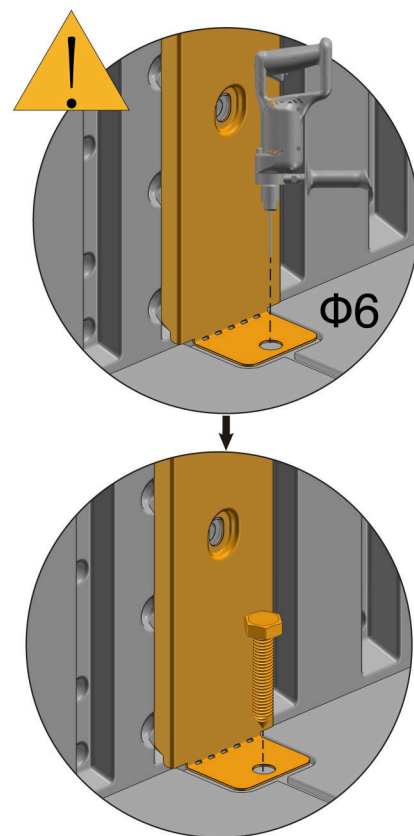
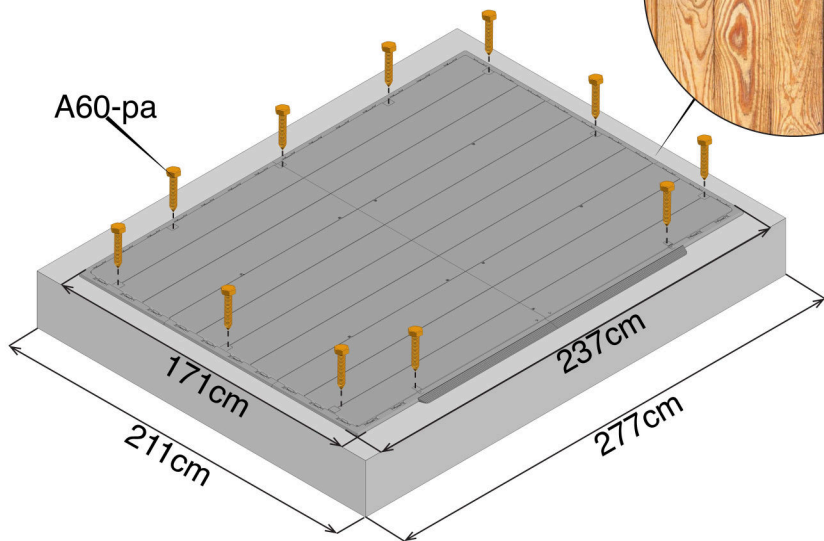

Montaż na betonowej podstawie/ Assembly on a concrete base

