

PLAYGROUND SPIELPLATZ

GIOCO AIRE DE JEUX

(384 x 408 x h262cm)

003_08810_10102024

FLUPPI V2

INSTALLATION INSTRUCTIONS
MONTAGEANLEITUNG

ISTRUZIONI DI MONTAGGIO
GUIDE D'INSTALLATION

Warranty period - 2 years from purchase date

Garantiezeit - 2 Jahre ab Kaufdatum

Periodo di garanzia - 2 anni dalla data di acquisto

Période de garantie - 2 ans à compter de l'achat

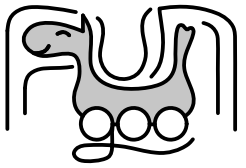

fungoo®

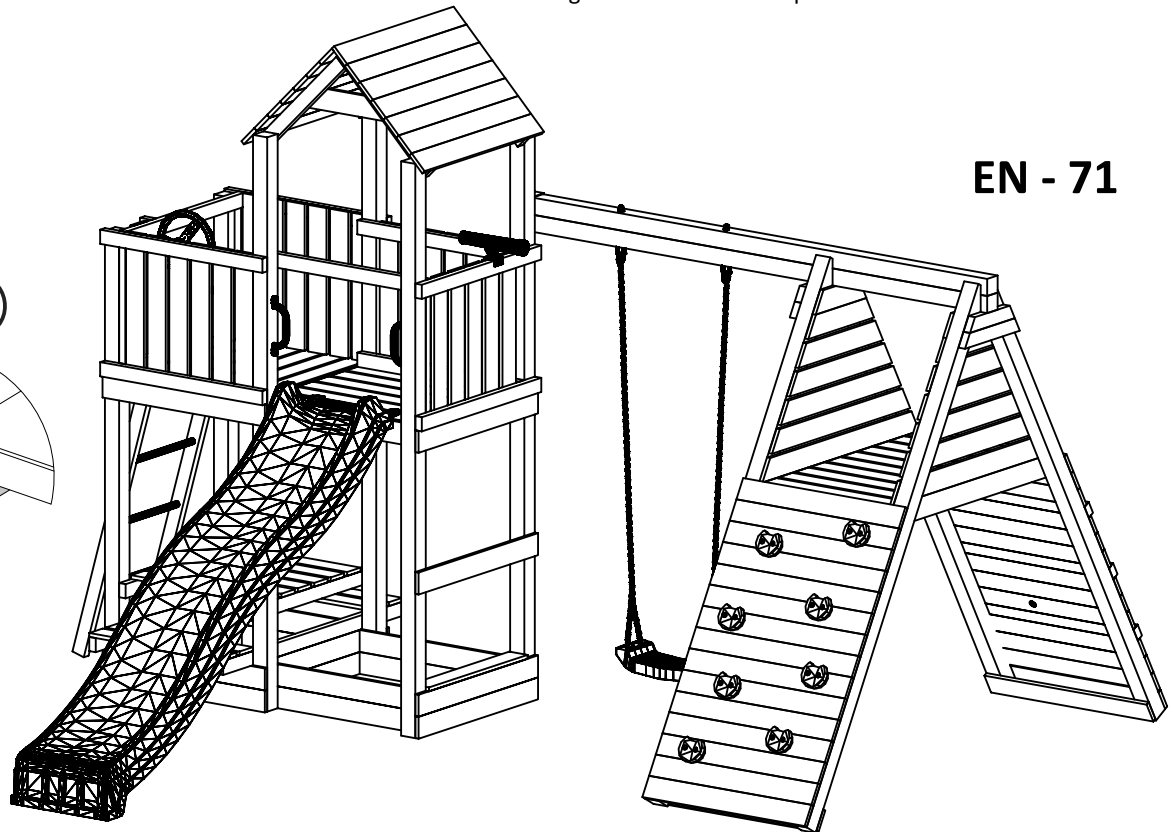
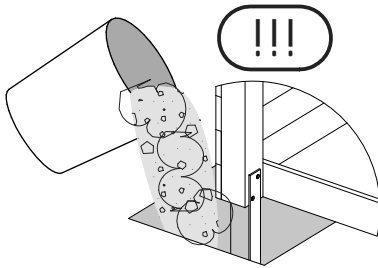

WARNINGS!

Only for home use.

Dedicated for external use only.

Not suitable for children under 3 years old.

Risk of falling down and/or hitting.

Maximum user weight is up to 50 kg.

Maximum number of users staying on the
playground at the same time: 10.

ATTENZIONE!

Solo per uso domestico.

Articolo per uso esterno.

Previsto per bambini di età superiore ai 3 anni.

Pericolo di caduta, e/o impatto.

Peso massimo di utente : 50kg

Numero massimo di utilizzatori
del gioco nello stesso momento: 10.

ACHTUNG!

Nur für den privaten, häuslichen Bereich.

Ausschließlich für die Verwendung im Freien.

Nicht geeignet für Kinder unter 3 Jahren.

Stolper- und / oder Sturzgefahr

Höchstgewicht pro Einzelkind beträgt 50 kg

Der Aufenthalt auf diesem Spielturm ist max. : 10.

Kindern gleichzeitig erlaubt.

AVERTISSEMENT!

Aire exclusivement destinée à un usage privé.

Aire exclusivement destinée à un usage en extérieur.

Prévue pour les enfants de plus de 3 ans.

Danger de chute ou de choc.

Poids maximal d'un utilisateur : 50 kg.

Nombre maximal d'utilisateurs présents en
même temps sur la même aire de jeux: 10.

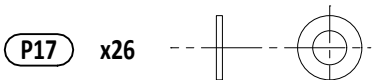
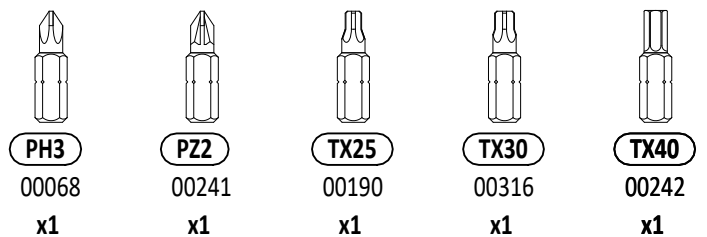
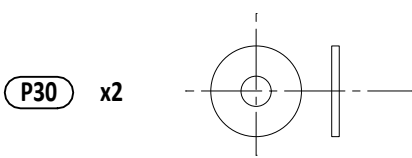
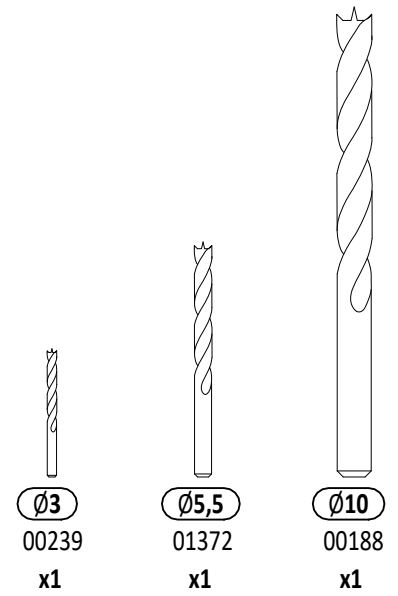
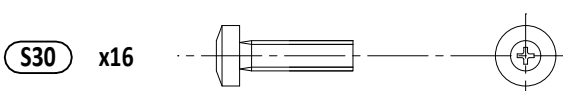
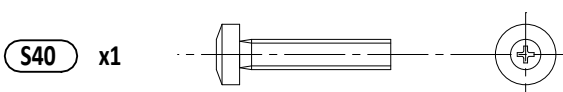
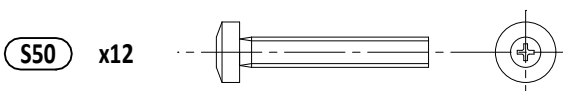
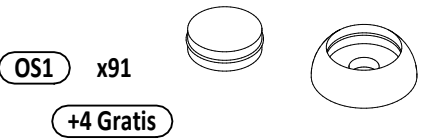
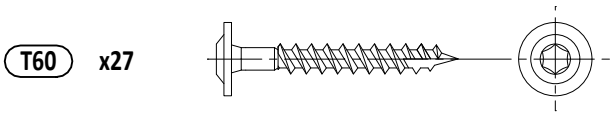
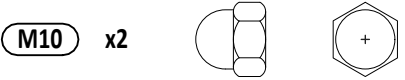
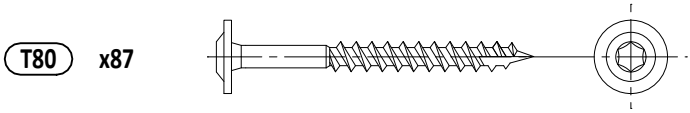
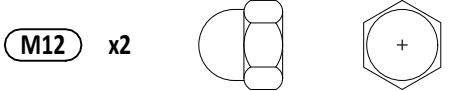
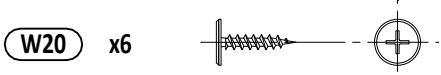
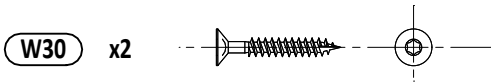
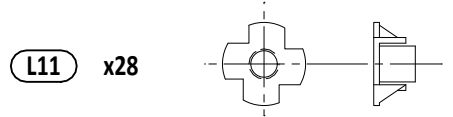
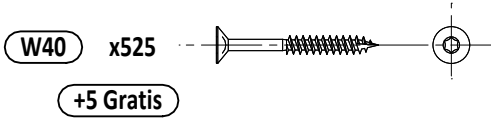
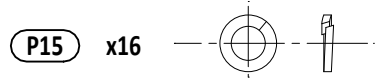
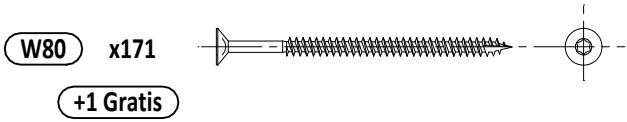

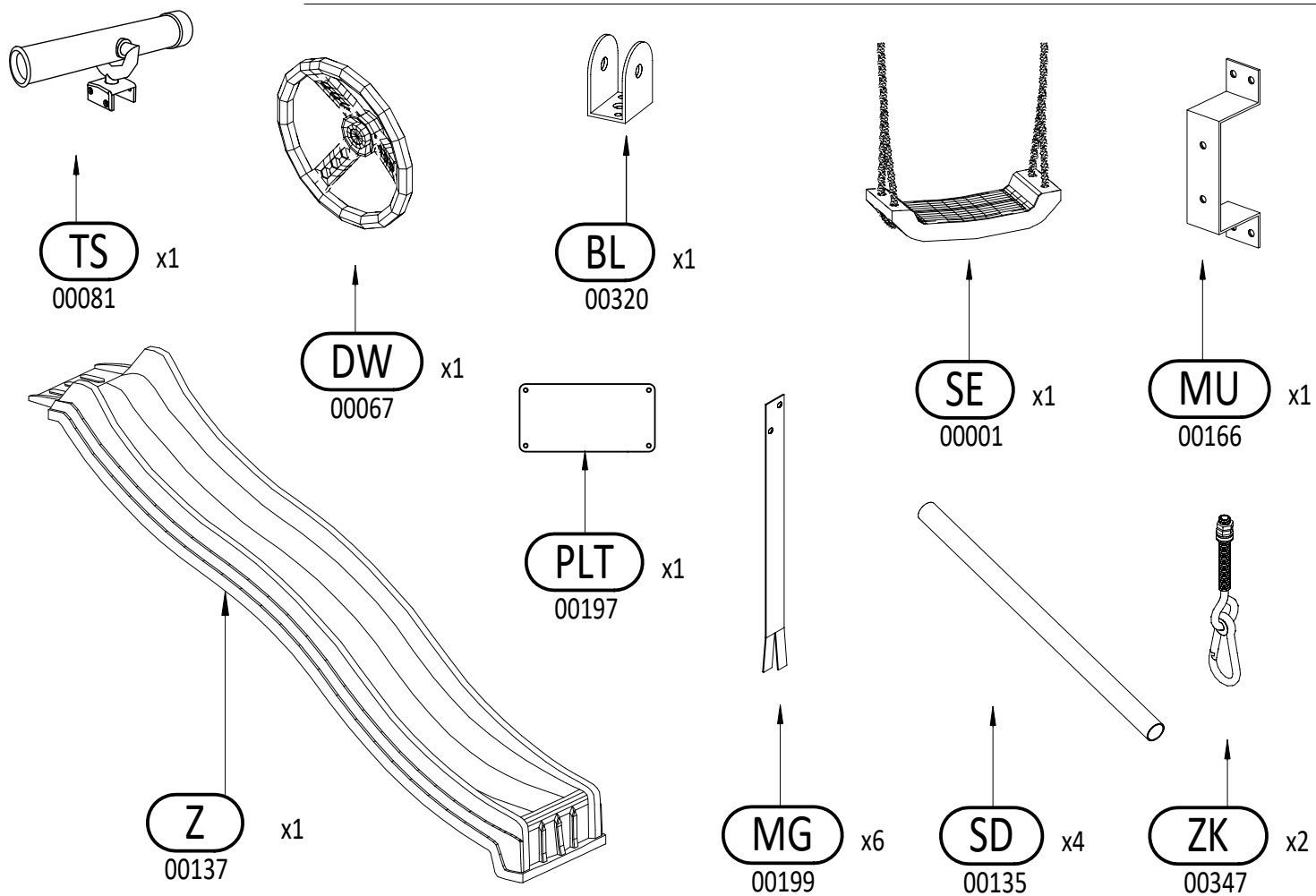
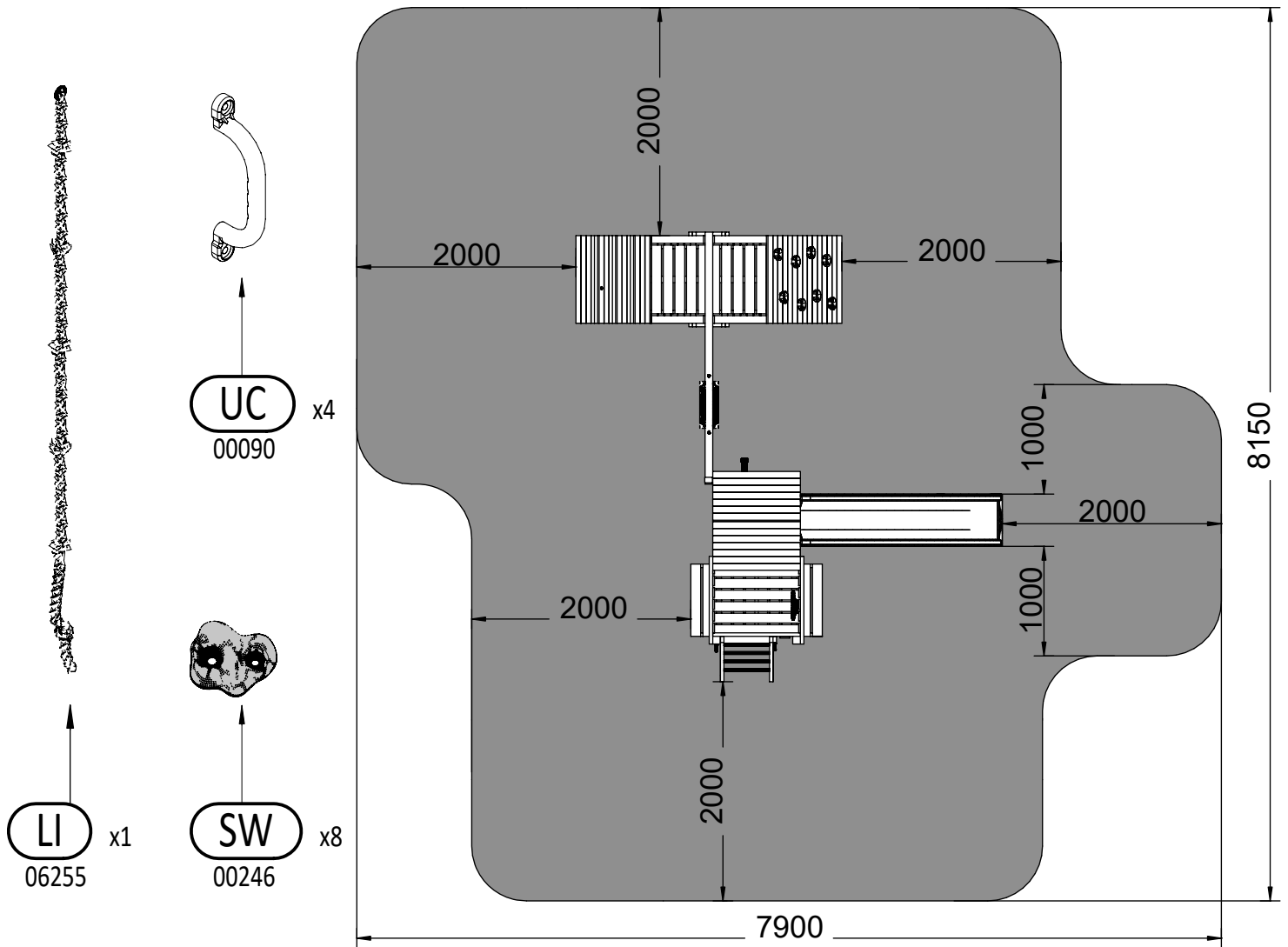

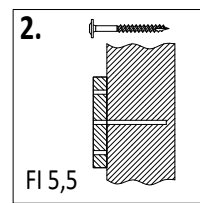
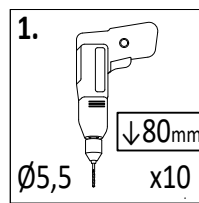
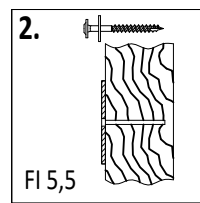
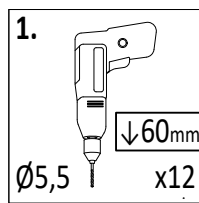
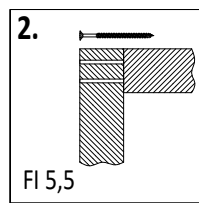
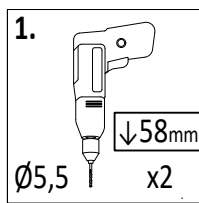
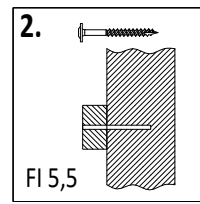
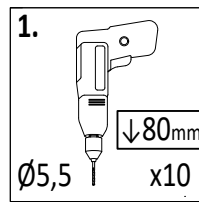
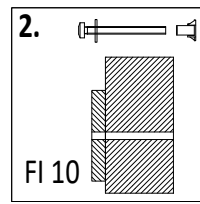
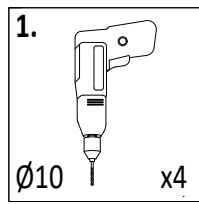
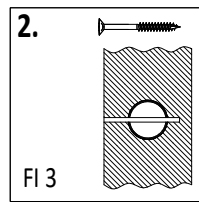
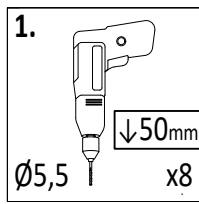
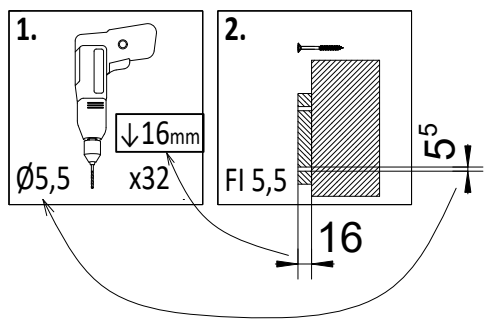
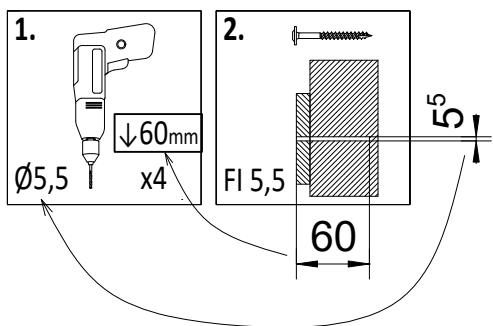
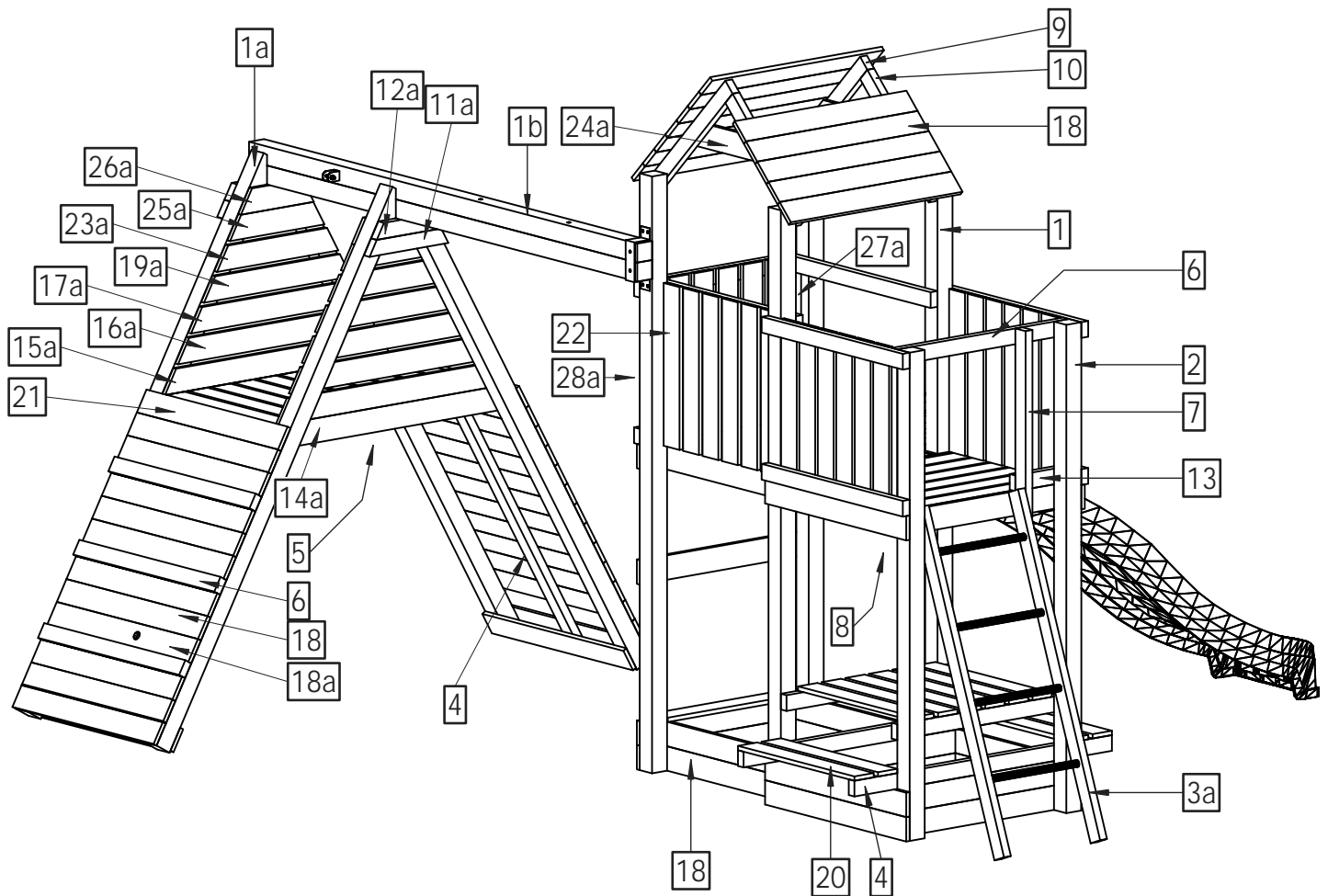

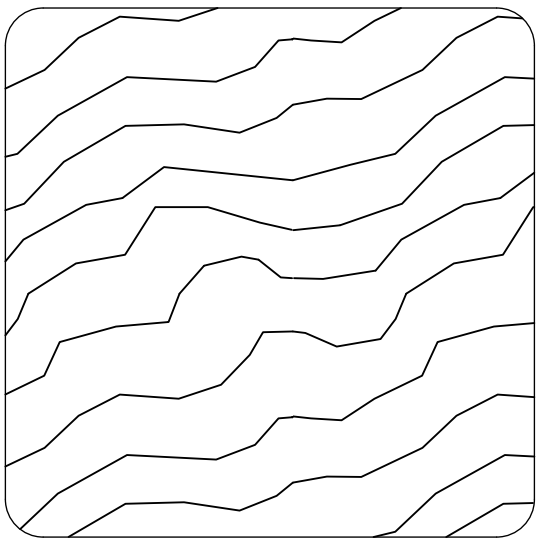

7,0 x 7,0 cm

| Lp. | Kod | Wymiary [mm] | szt. |
|-----|-------|--------------|------|
| 1 | 03901 | 70x70x2200mm | 4 |
| 1a | 08457 | 70x70x2200mm | 4 |
| 1b | 08421 | 70x70x2200mm | 2 |
| 2 | 05245 | 70x70x1800mm | 2 |

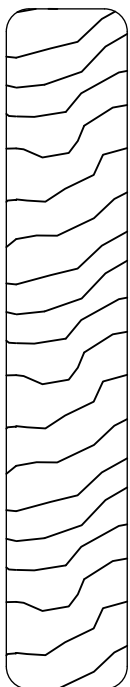

1,6 x 9,0 cm

| Lp. | Kod | Wymiary [mm] | szt. |
|-----|-------|--------------|------|
| 14a | 04916 | 16x90x1150mm | 2 |
| 15a | 04918 | 16x90x1050mm | 2 |
| 16a | 04920 | 16x90x925mm | 2 |
| 17a | 04922 | 16x90x805mm | 2 |
| 18 | 04465 | 16x90x800mm | 77 |
| 18a | 04393 | 16x90x800mm | 1 |
| 19a | 04924 | 16x90x685mm | 2 |
| 20 | 04096 | 16x90x660mm | 11 |
| 21 | 04914 | 16x90x628mm | 10 |
| 22 | 04625 | 16x90x600mm | 24 |
| 23a | 04926 | 16x90x565mm | 2 |
| 24a | 04467 | 16x90x560mm | 2 |
| 25a | 04928 | 16x90x440mm | 2 |
| 26a | 04930 | 16x90x340mm | 2 |

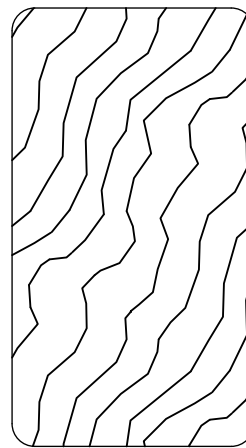

3,2 x 5,8 cm

| Lp. | Kod | Wymiary [mm] | szt. |
|-----|-------|--------------|------|
| 3a | 04613 | 32x58x1300mm | 2 |
| 4 | 03889 | 32x58x1200mm | 3 |
| 5 | 04906 | 32x58x1065mm | 3 |
| 6 | 04457 | 32x58x800mm | 15 |
| 7 | 04615 | 32x58x690mm | 1 |
| 8 | 04459 | 32x58x628mm | 6 |
| 9 | 04617 | 32x58x610mm | 2 |
| 10 | 04619 | 32x58x550mm | 2 |
| 11a | 04908 | 32x58x367mm | 2 |
| 12a | 04910 | 32x58x300mm | 2 |
| 13 | 04621 | 32x58x250mm | 1 |

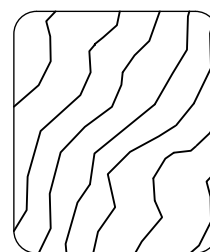

2,7 x 3,2 cm

| Lp. | Kod | Wymiary [mm] | szt. |
|-----|-------|--------------|------|
| 27a | 04471 | 27x32x542mm | 2 |
| 28a | 04476 | 27x32x484mm | 2 |

1

7,0 x 7,0 x 220,0cm

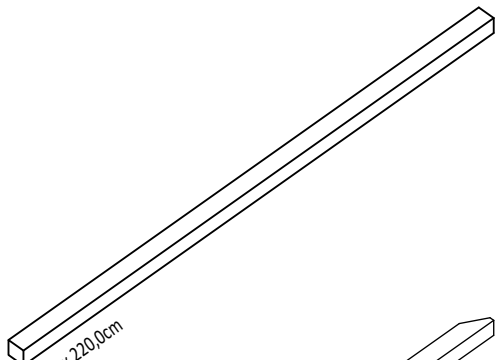

1a

7,0 x 7,0 x 220,0cm

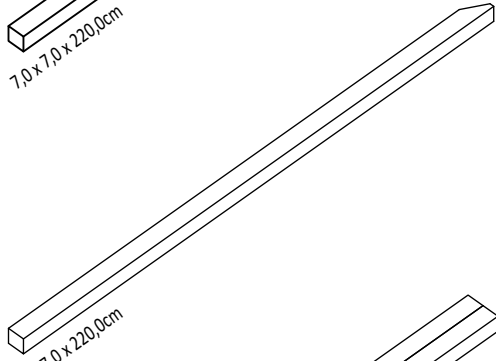

1b

7,0 x 14,0 x 220,0cm

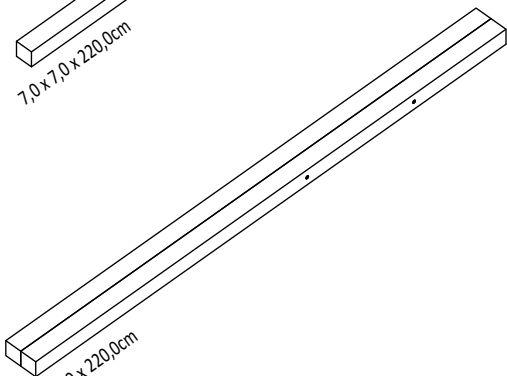

2

7,0 x 7,0 x 180,0cm

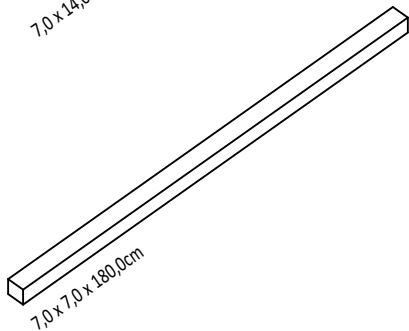

3a

3,2 x 5,8 x 130,0cm

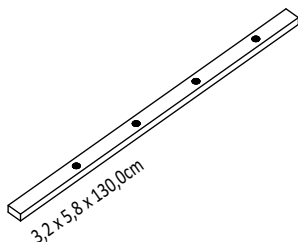

4

3,2 x 5,8 x 120,0cm

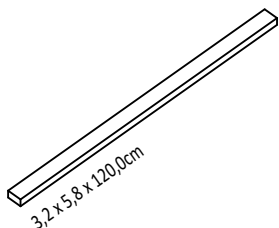

5

3,2 x 5,8 x 106,5cm

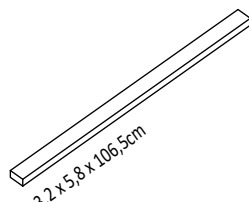

6

3,2 x 5,8 x 80,0cm

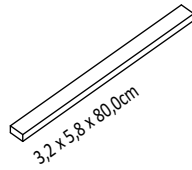

7

3,2 x 5,8 x 69,0cm

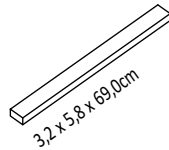

8

3,2 x 5,8 x 62,8cm

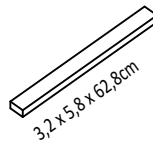

9

3,2 x 5,8 x 61,0cm

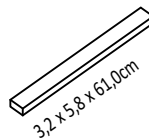

10

3,2 x 5,8 x 55,0cm

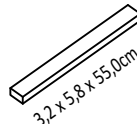

12a

3,2 x 5,8 x 30,0cm



11a

3,2 x 5,8 x 36,7cm

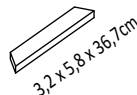

13

3,2 x 5,8 x 25,0cm



14a

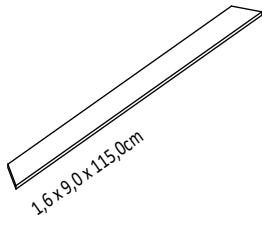

20

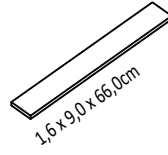

27a



15a

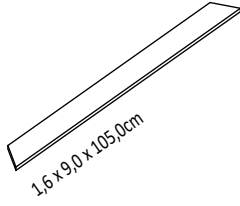

21

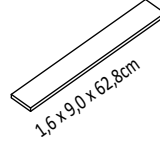

28a



16a

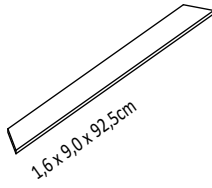

22

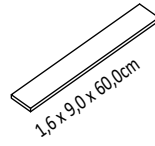

17a

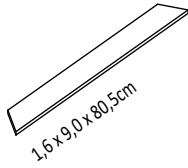

23a

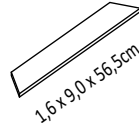

18

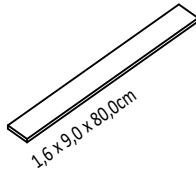

24a

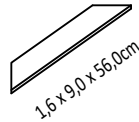

18a

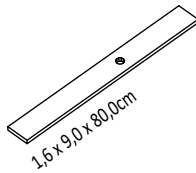

25a

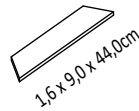

19a

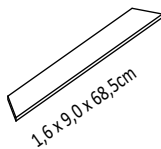

26a

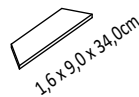

01

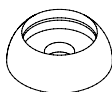
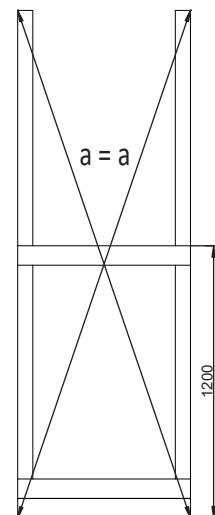
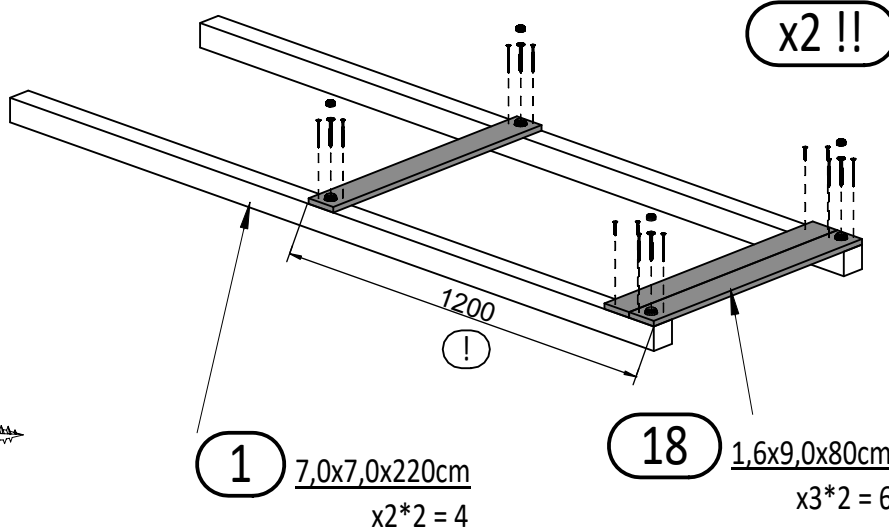
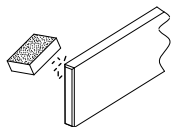
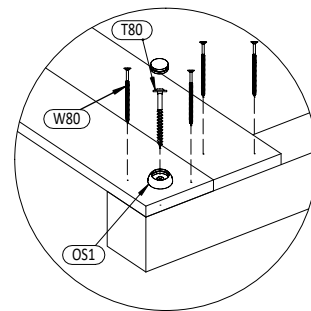
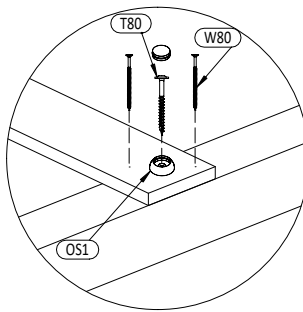
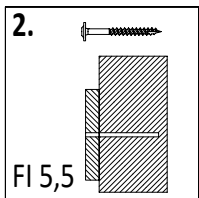
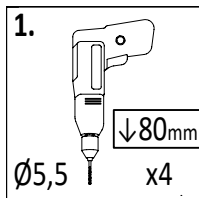

OS1 x4*2 = 8

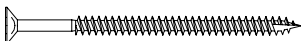

W80 x12*2 = 24

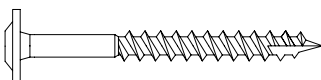

T80 x4*2 = 8

02

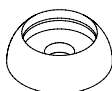
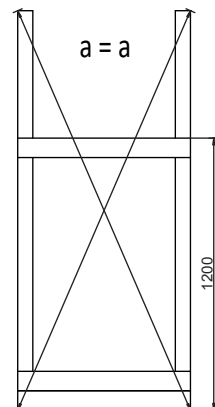
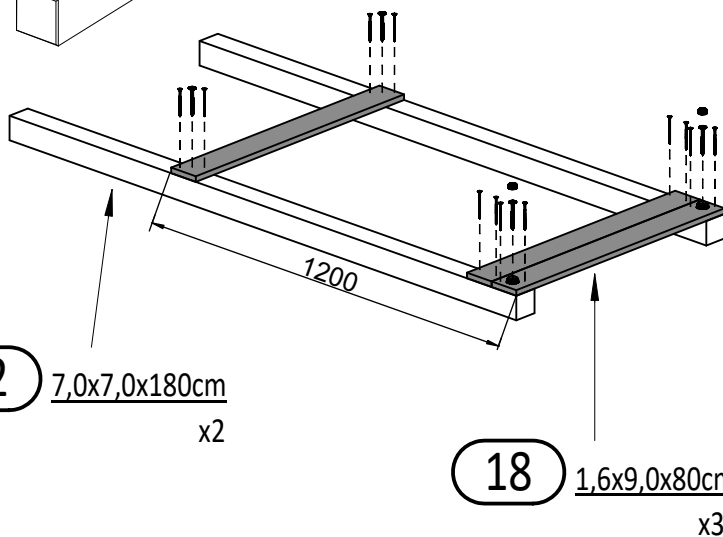
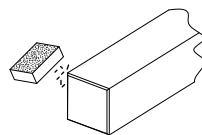
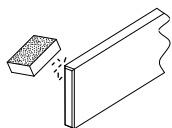
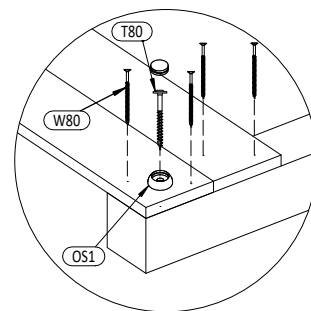
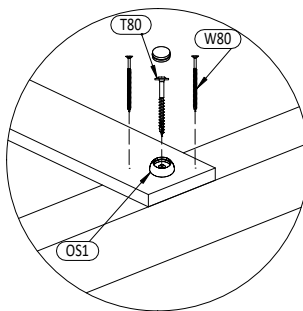
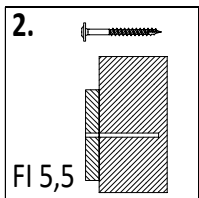
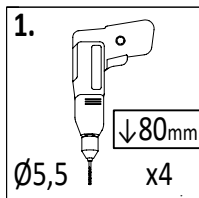

OS1 x2

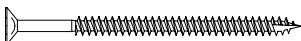

W80 x12

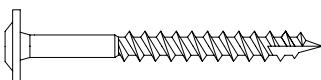

T80 x4

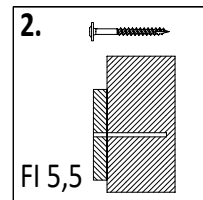
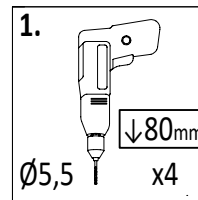
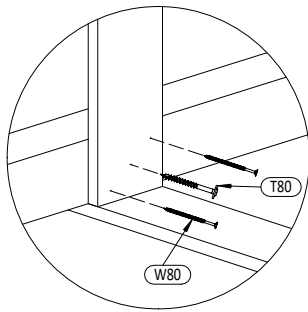

18 1,6x9,0x80cm
x6

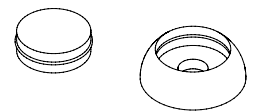
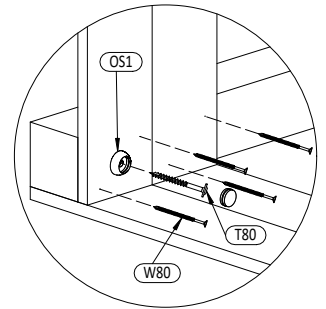
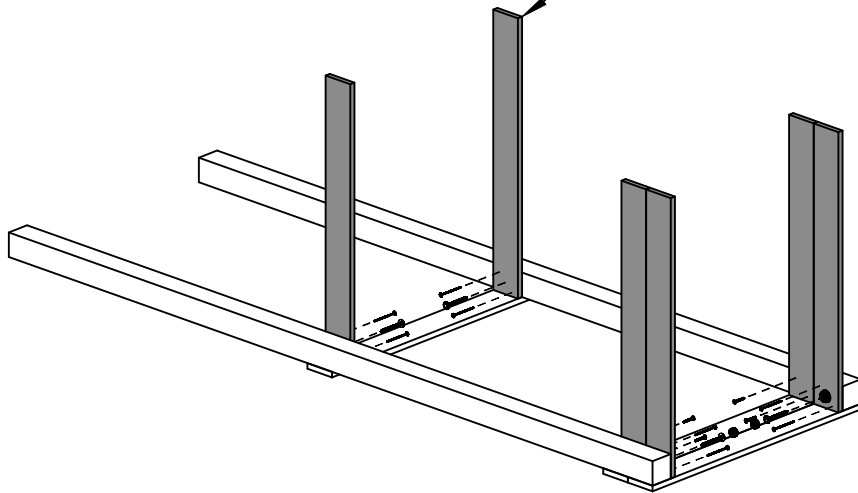

OS1 x2

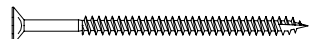

W80 x12

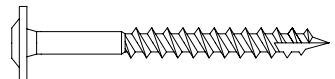

T80 x4

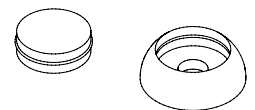
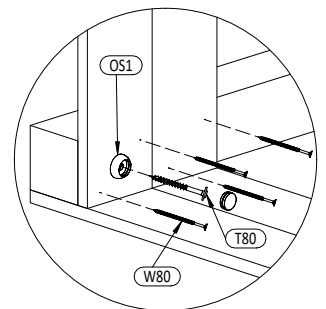
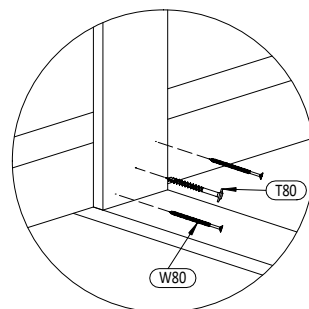
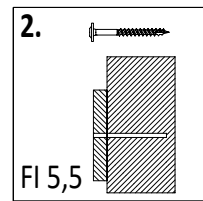
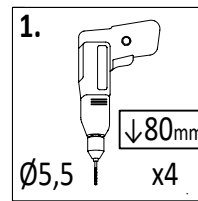
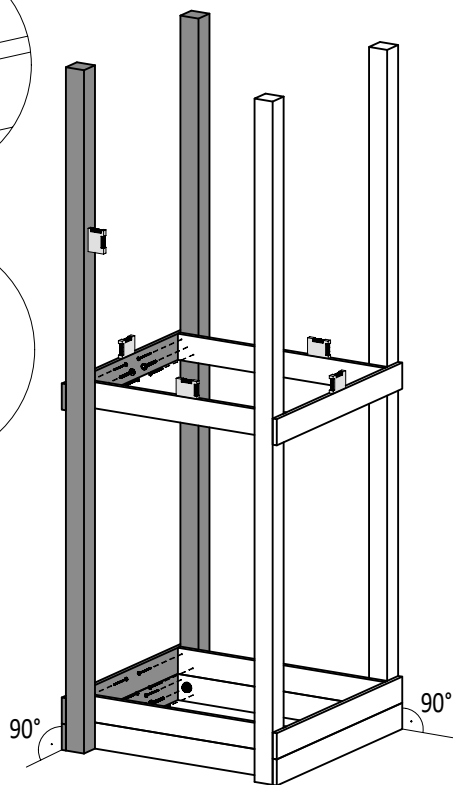
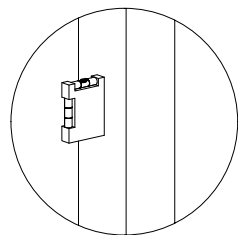
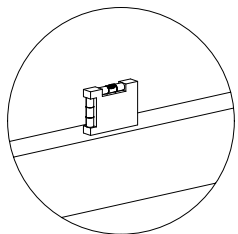

OS1 x2

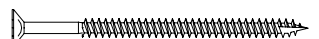

W80 x12

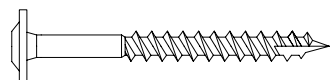

T80 x4

05

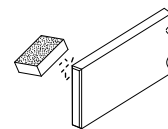
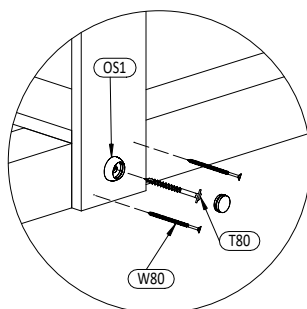
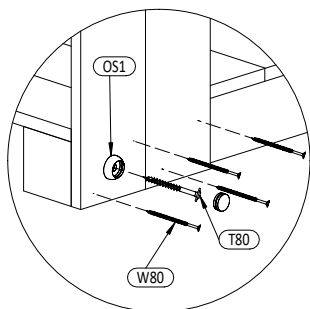
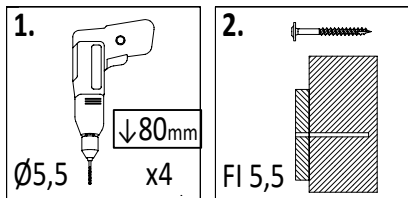

18 1,6x9,0x80cm
x6

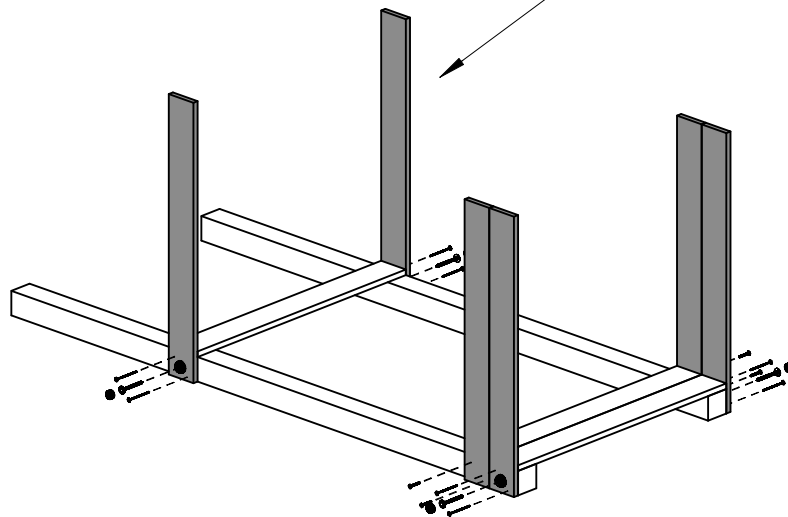

OS1 x4



W80 x12

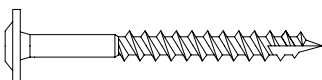

T80 x4

06

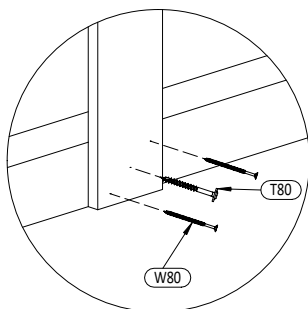
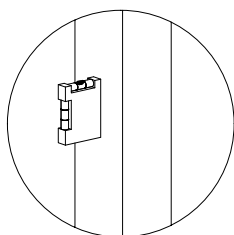
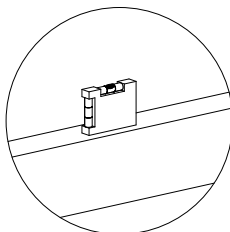
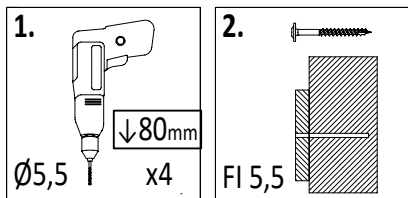

OS1 x4



W80 x12

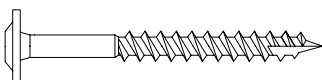

T80 x4

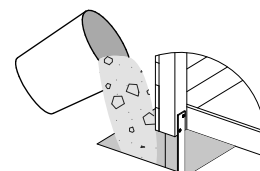
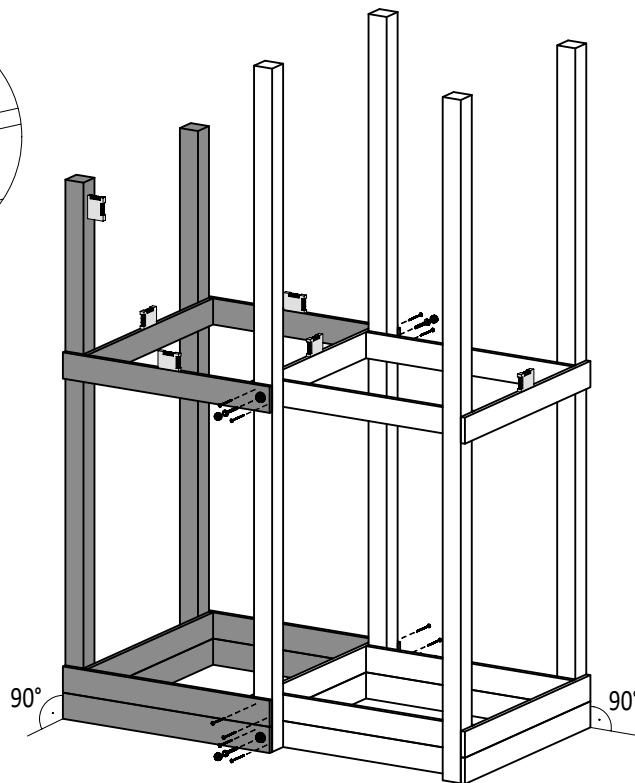
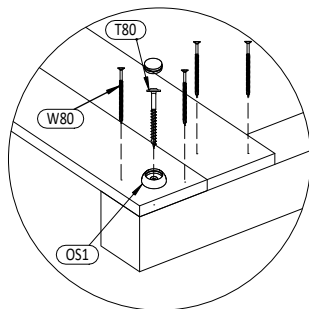

10 FLUPPI V2

Zgodnie z normą PN-EN 71 stosuj zalecenia producenta odnośnie odległości oraz metody mocowania poszczególnych elementów
In compliance with the standard PN-EN 71, apply guidelines of the producer in relation to distances and methods of fastening individual elements

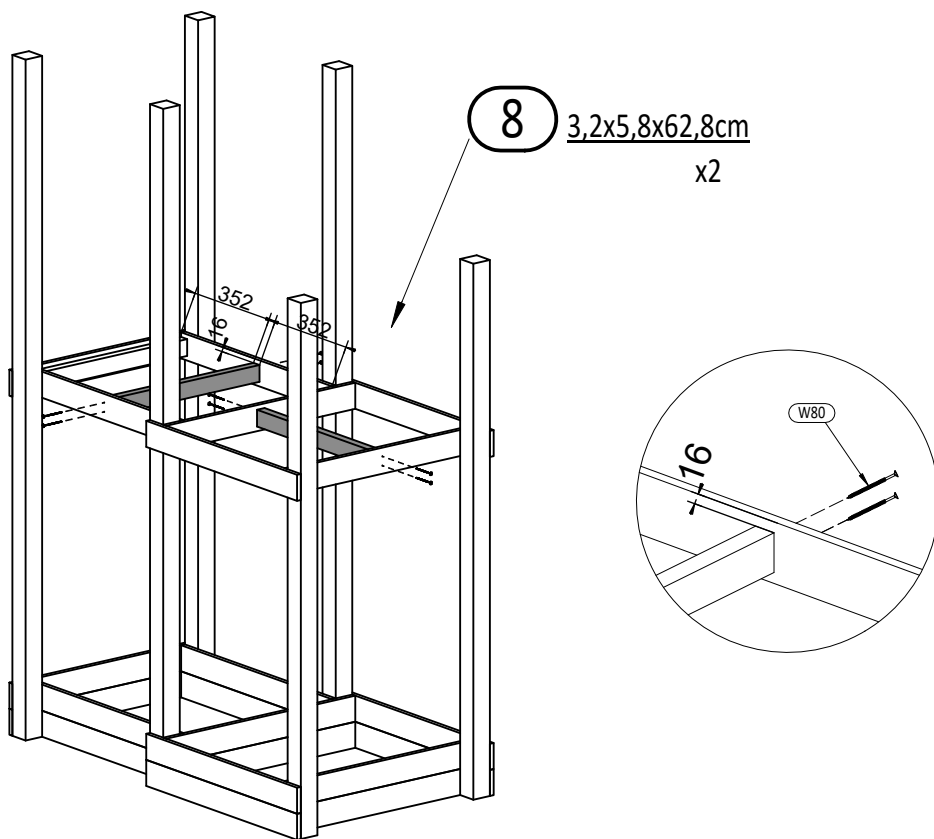

8 3,2x5,8x62,8cm
x2

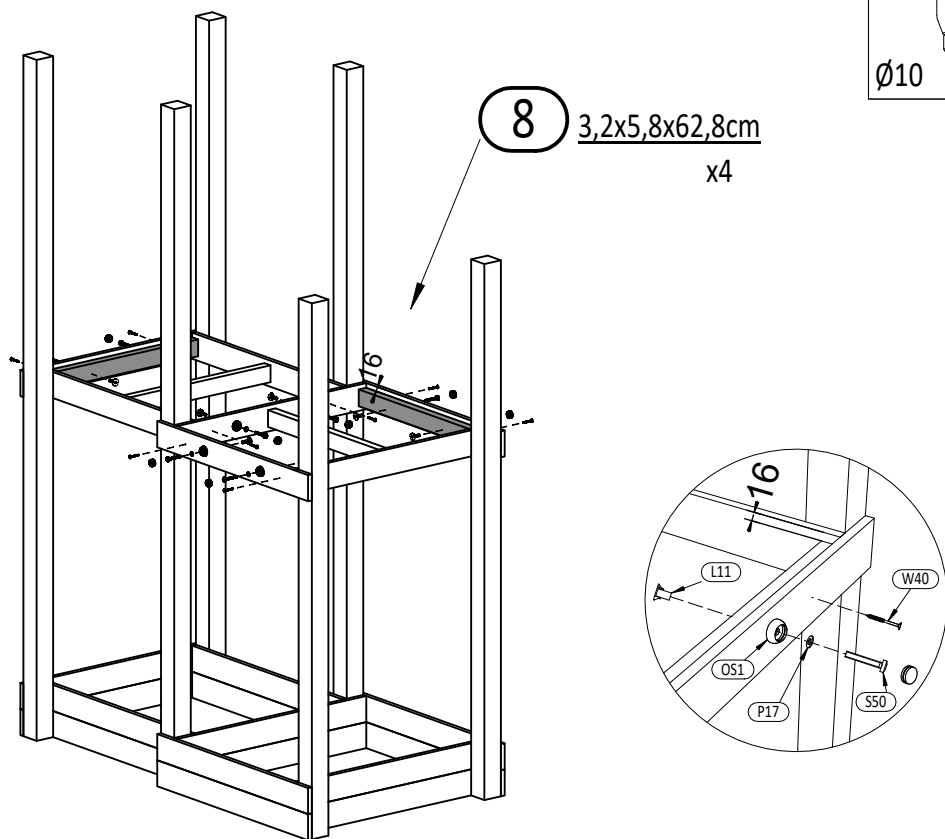

8 3,2x5,8x62,8cm
x4

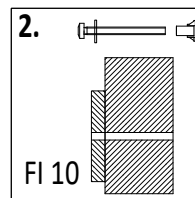
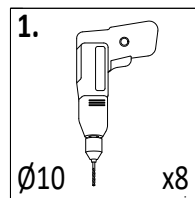

OS1 x8



W40 x8

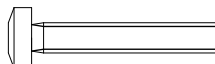

S50 x8



P17 x8



L11 x8

09

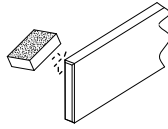
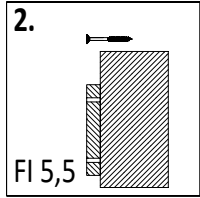
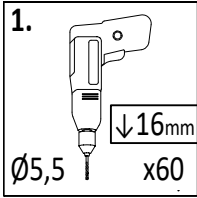

18 $1,6 \times 9,0 \times 80\text{cm}$
x12

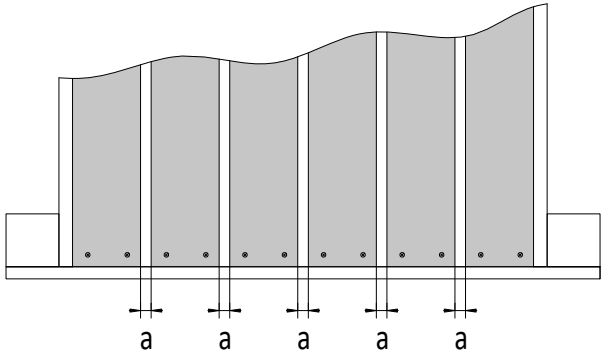

!!!min 13mm < **a** <!!!max 18mm

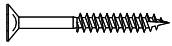
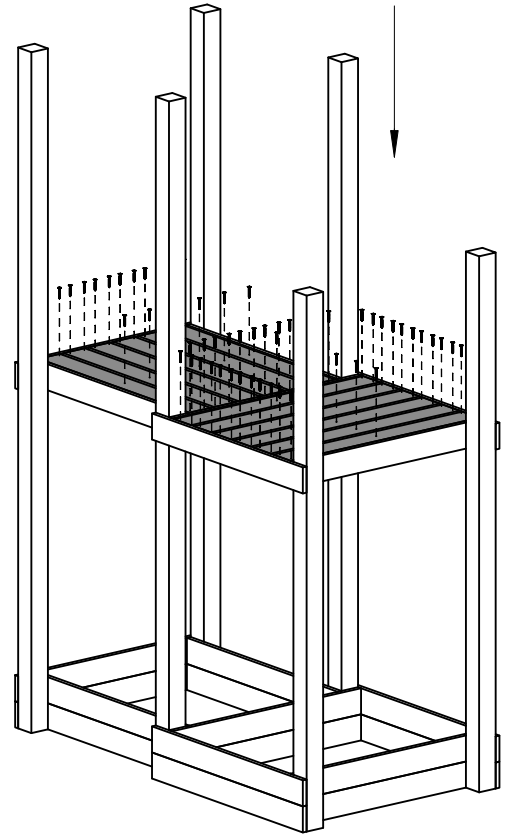

W40 x60

10

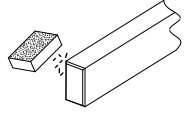
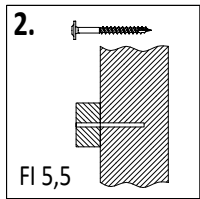
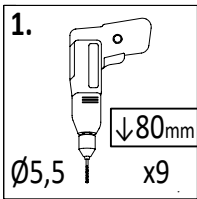

13 $3,2 \times 5,8 \times 25\text{cm}$
x1

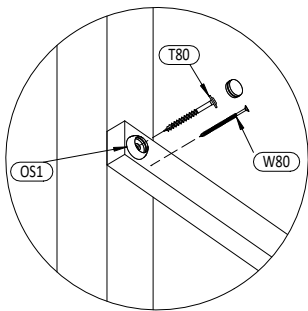

OS1 x9



W80 x9



T80 x9

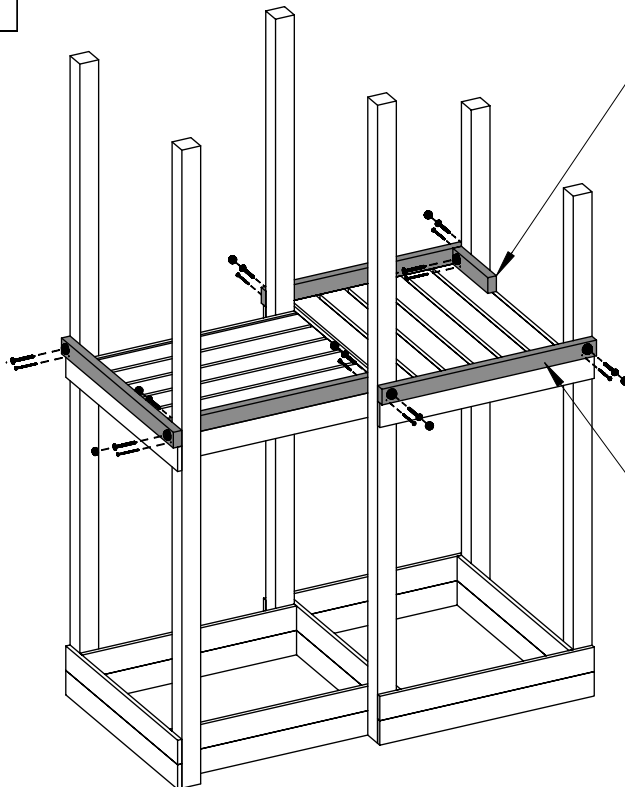

6 $3,2 \times 5,8 \times 80\text{cm}$
x4

6 3,2x5,8x80cm x6

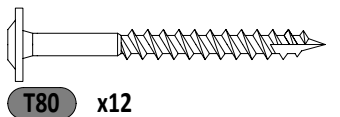
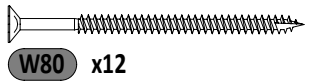
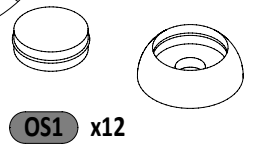
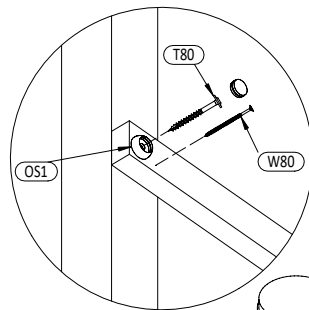
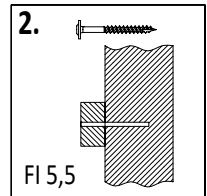
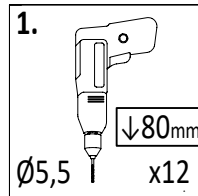
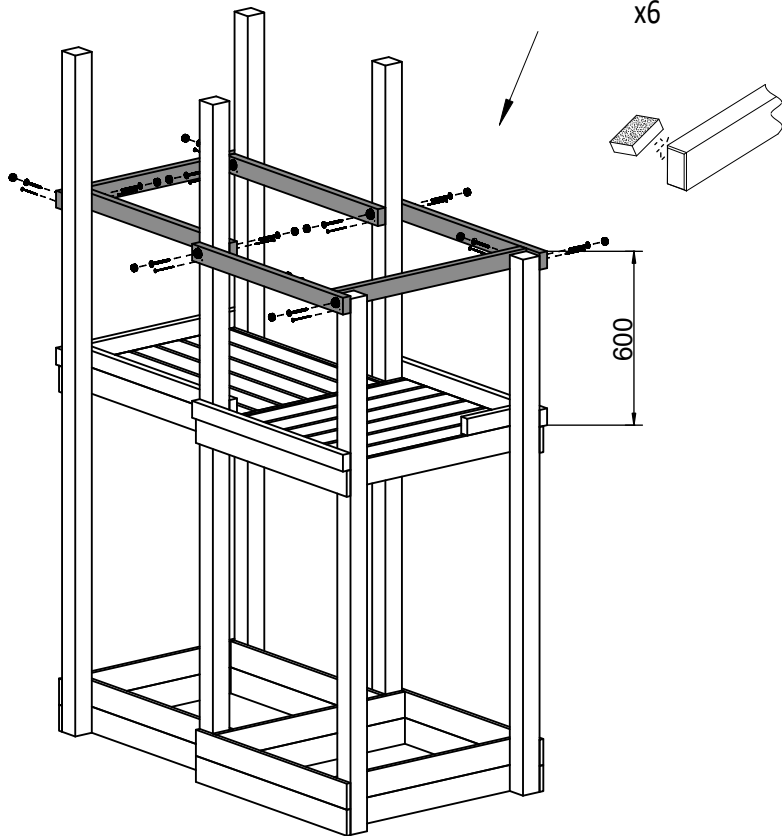

7 3,2x5,8x69cm x1

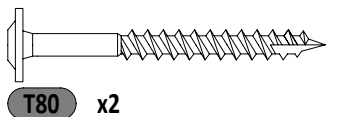
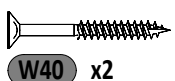
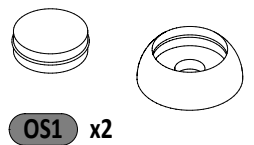
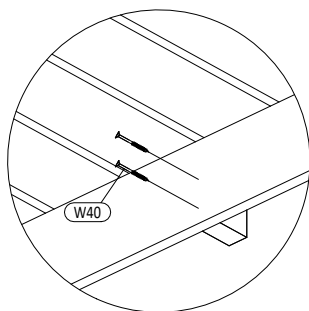
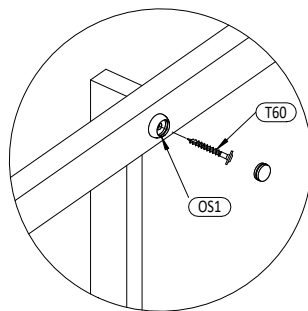
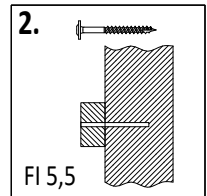
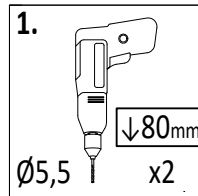
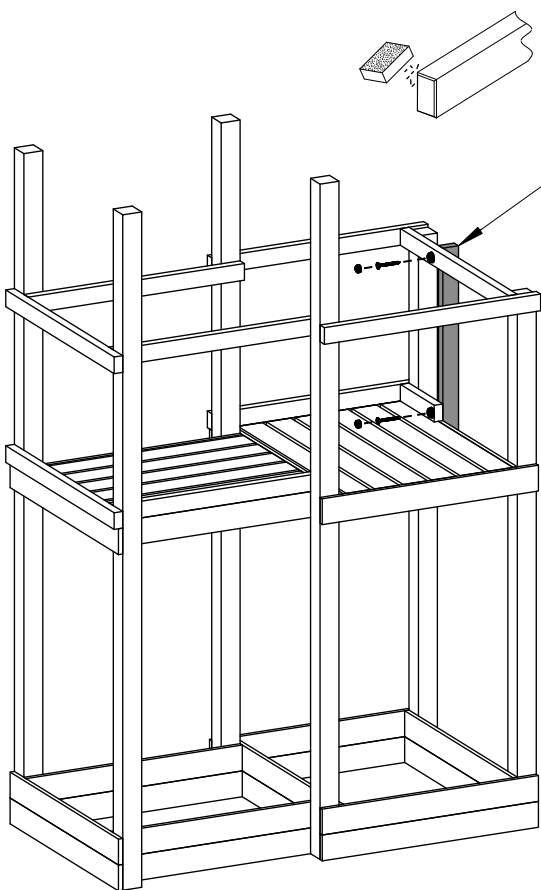

13

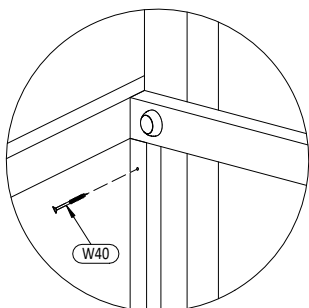
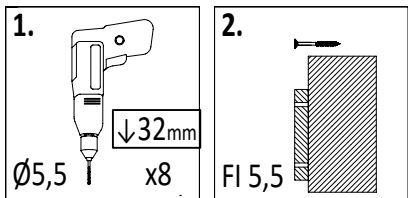

28a

2,7x3,2x48,4cm

27a

2,7x3,2x54,2cm

x2

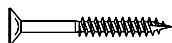
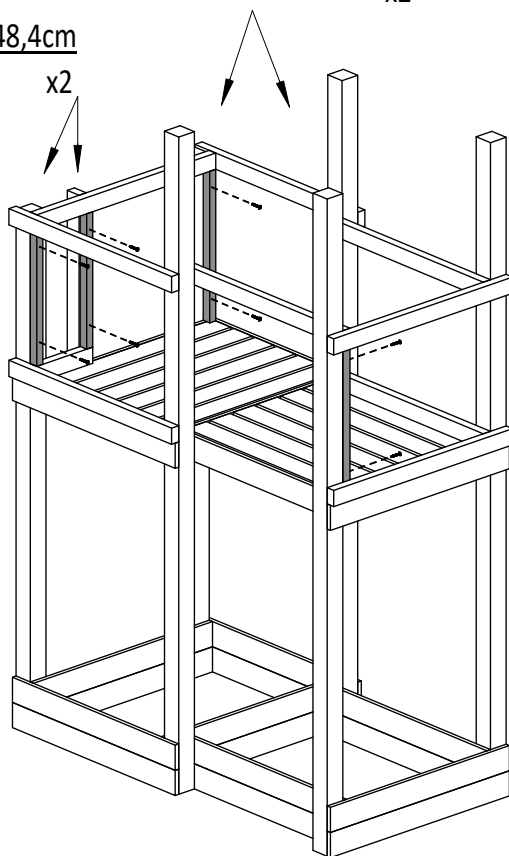

W40 x8

14

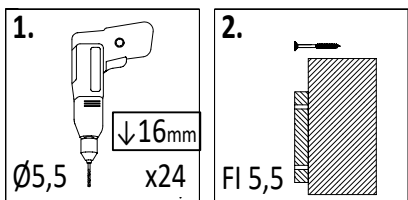

22

1,6x9,0x60cm

22

1,6x9,0x60cm

x5

x1

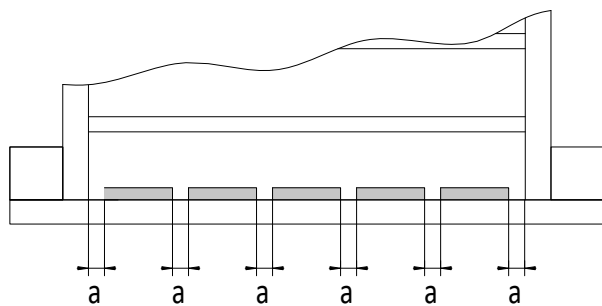
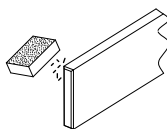

!!!min 13mm < a < !!!max 23mm

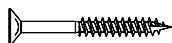
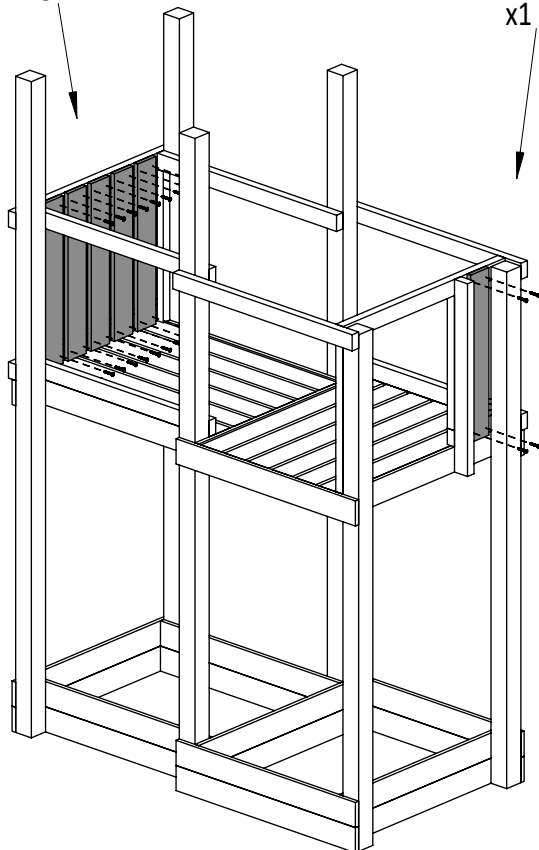

W40 x24

22

1,6x9,0x60cm

x6

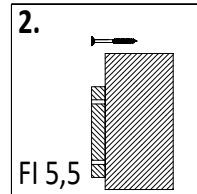
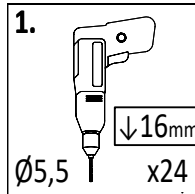
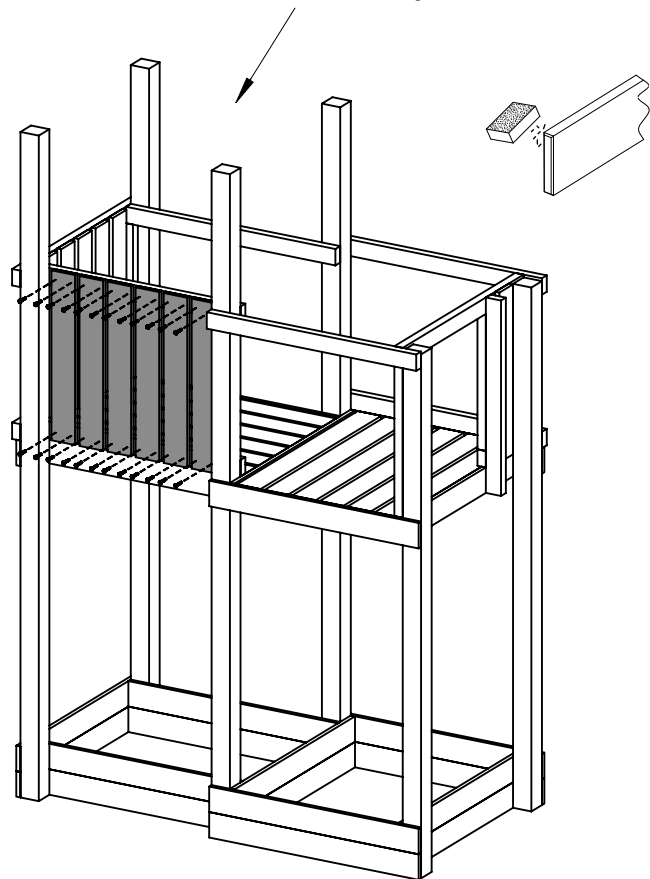

15

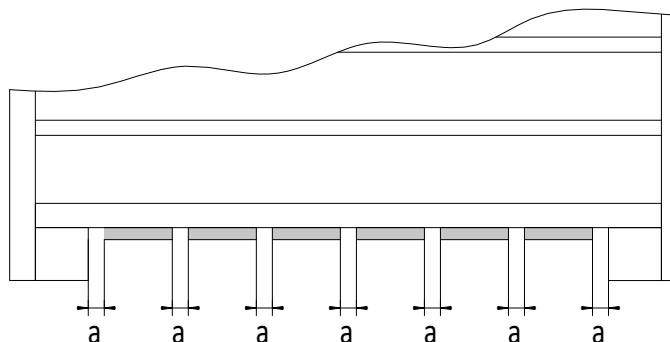

!!!min 13mm < a <!!!max 23mm

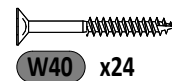

22

1,6x9,0x60cm

x12

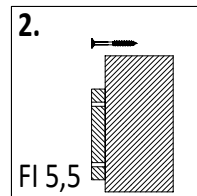
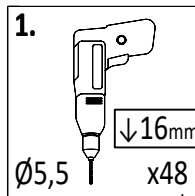
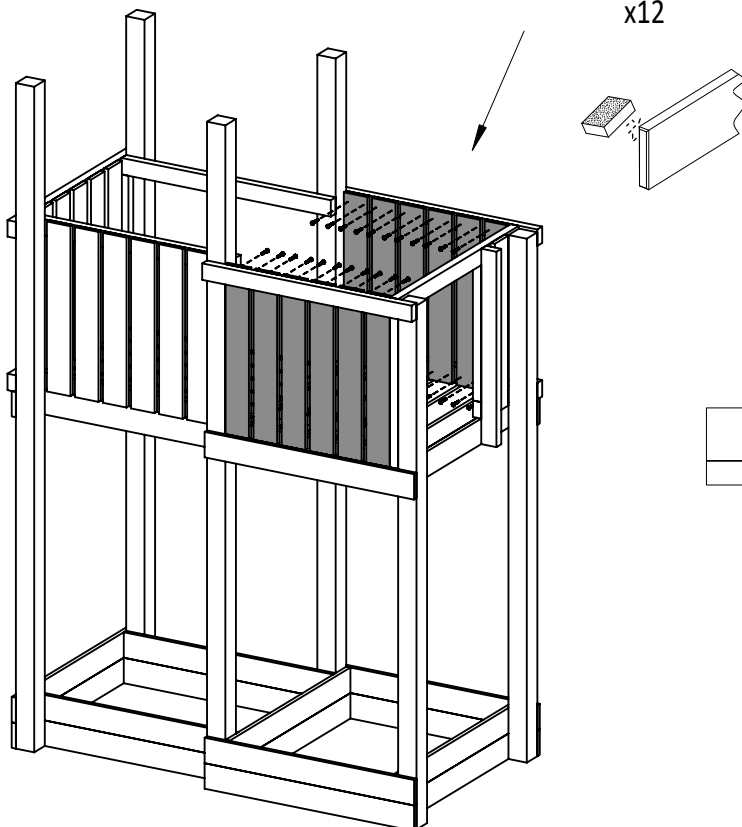

16

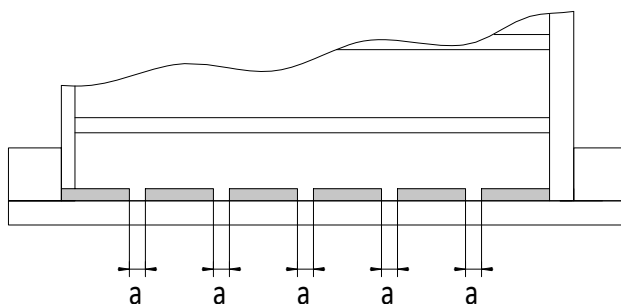

!!!min 13mm < a <!!!max 17mm

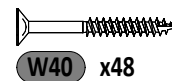

17

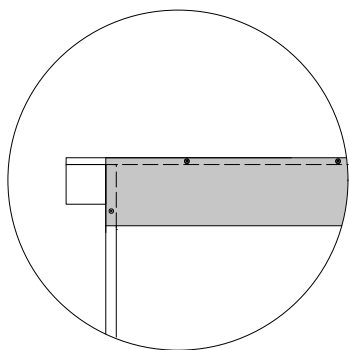
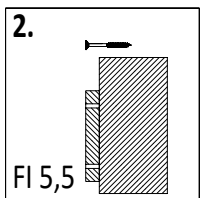
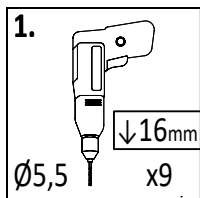

18 1,6x9,0x80cm
x1

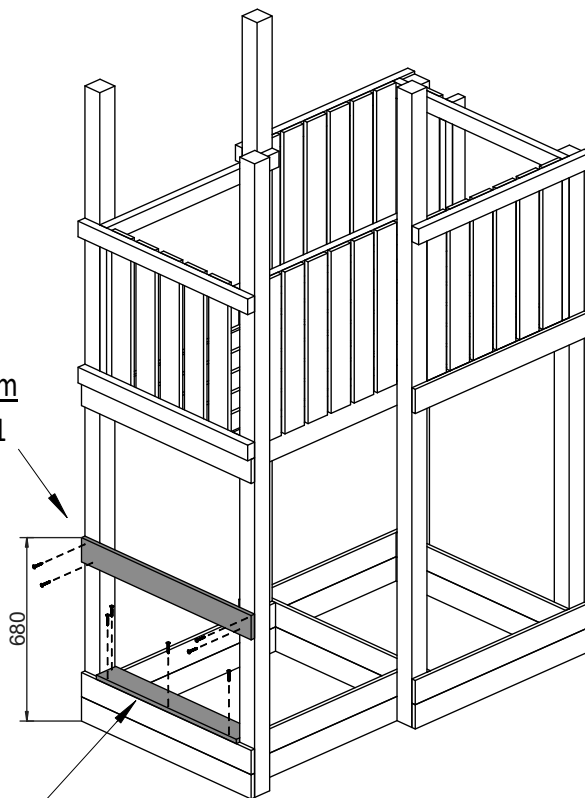
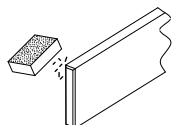

20 1,6x9,0x66cm
x1

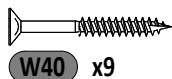

18

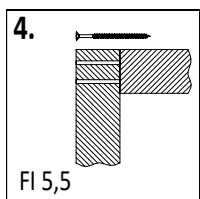
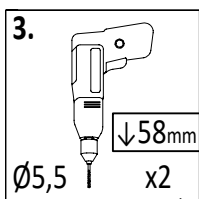
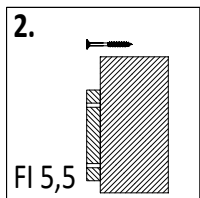
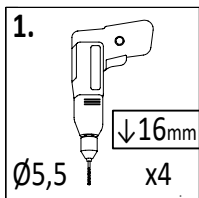

24a 1,6x9,0x56cm
x1*2 = 2

x2

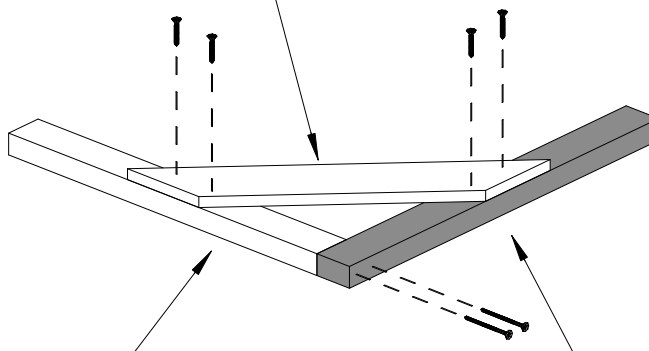
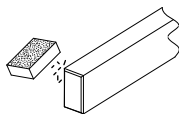

10 3,2x5,8x55cm
x1*2 = 2

9 3,2x5,8x61cm
x1*2 = 2

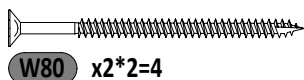
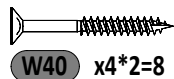

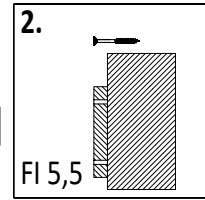
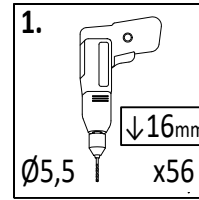
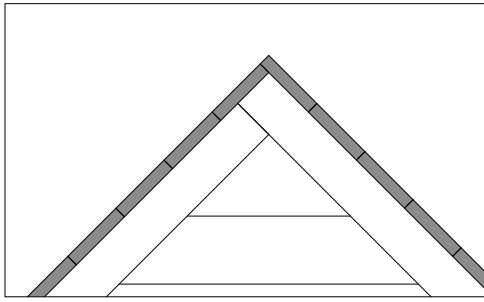

19

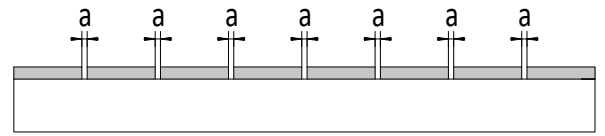

18 1,6x9,0x80cm
x14

!!!min 2mm < a < !!!max 6mm

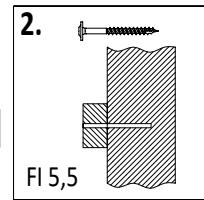
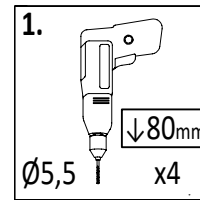
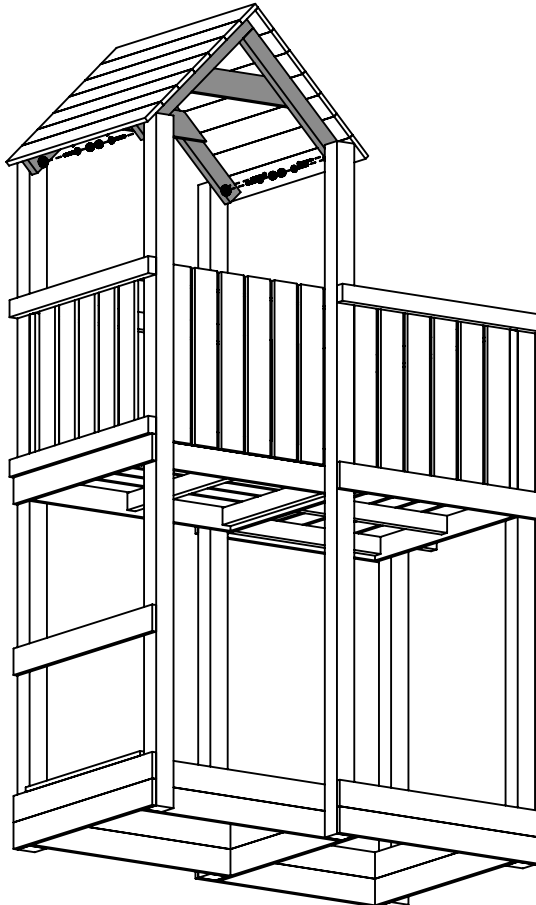
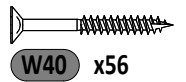
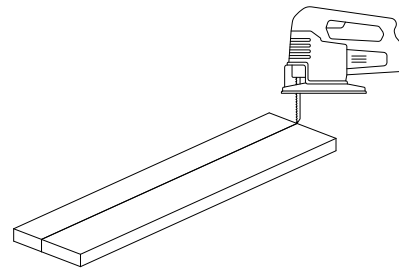
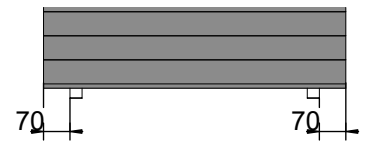
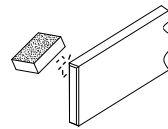
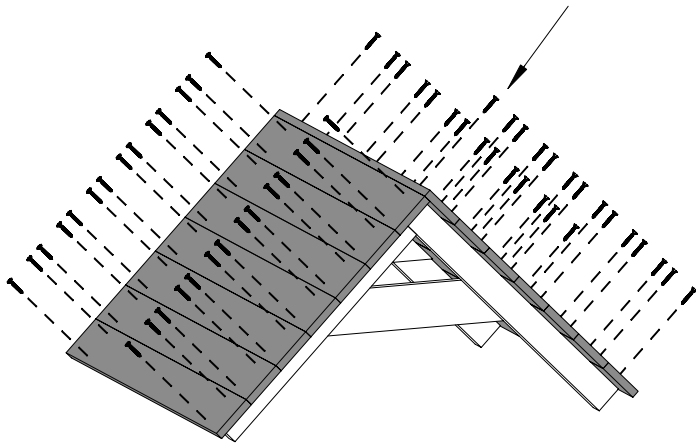

20

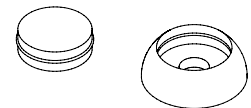
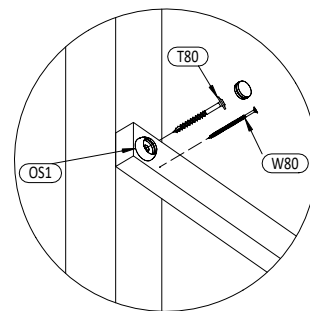

OS1 x4

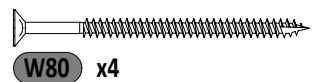

W80 x4

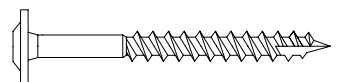

T80 x4

21

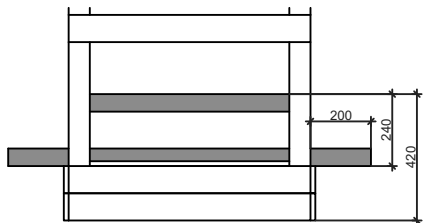
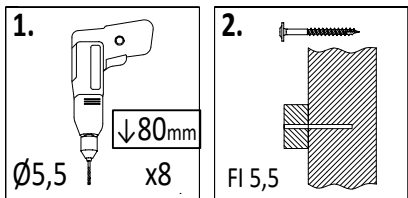

OS1 x8

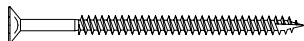

W80 x8

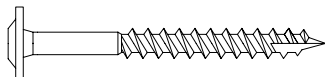

T80 x8

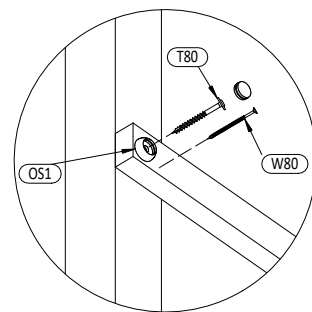
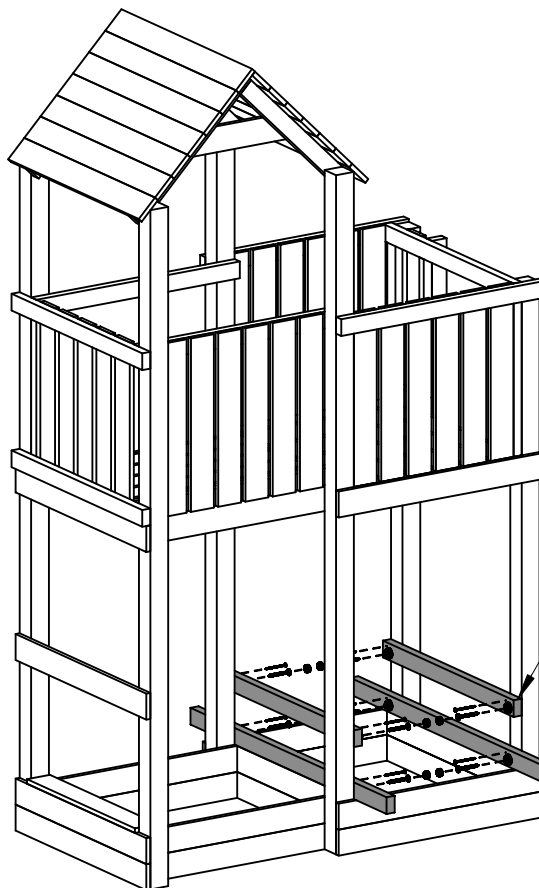

6 3,2x5,8x80cm
x2

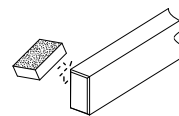

4 3,2x5,8x120cm
x2

22

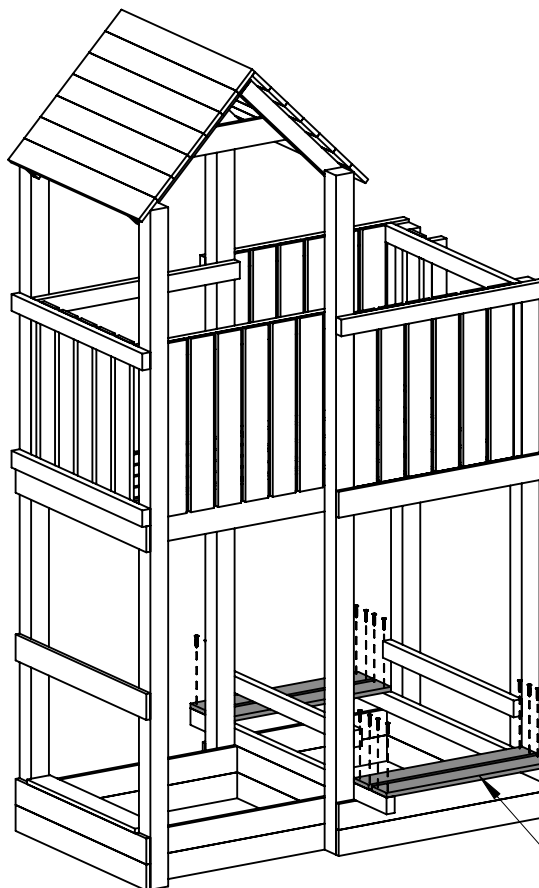
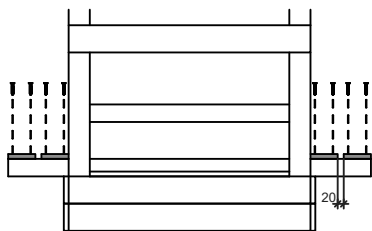
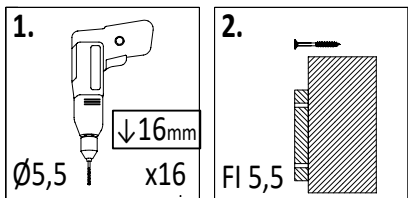

20 1,6x9,0x66cm
x4

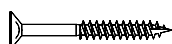
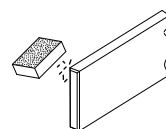

W40 x16

18 FLUPPI V2

Zgodnie z normą PN-EN 71 stosuj zalecenia producenta odnośnie odległości oraz metody mocowania poszczególnych elementów
In compliance with the standard PN-EN 71, apply guidelines of the producer in relation to distances and methods of fastening individual elements

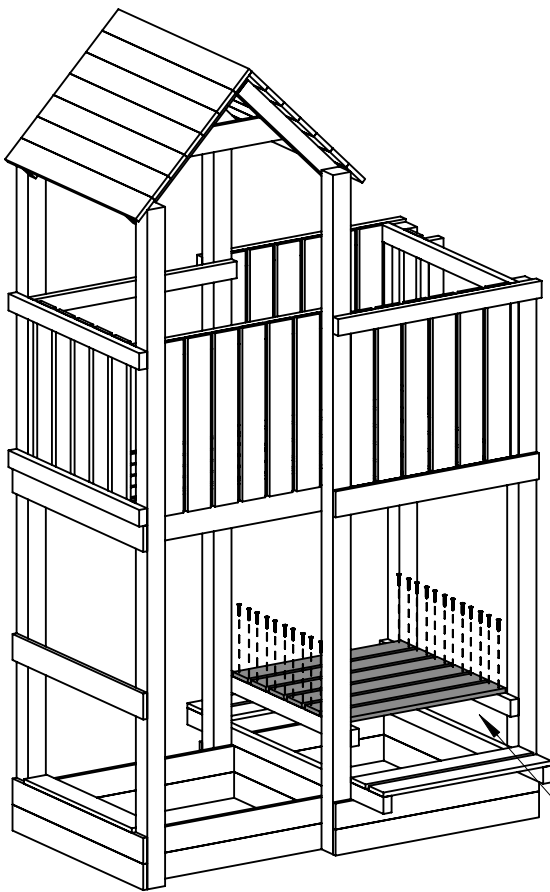
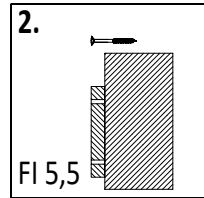
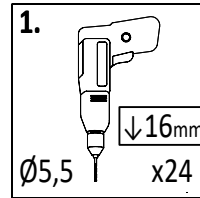

20 1,6x9,0x66cm
x6

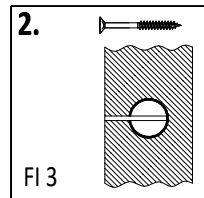
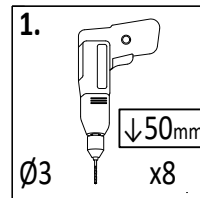
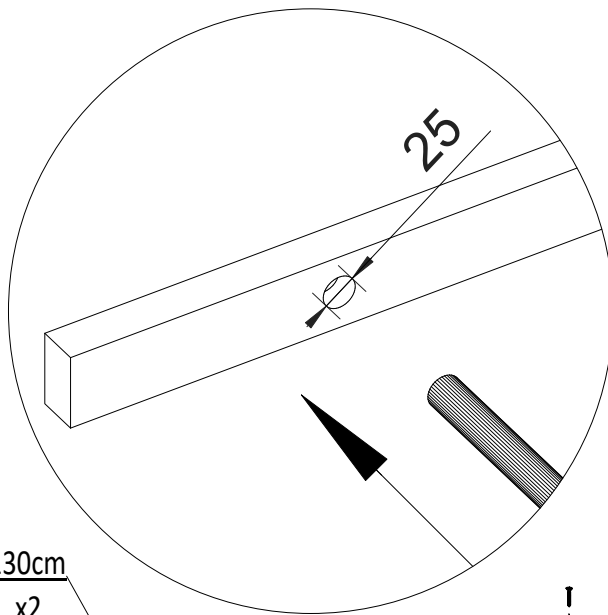
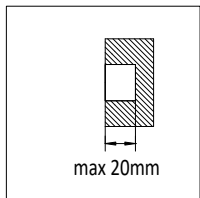
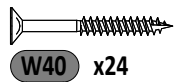
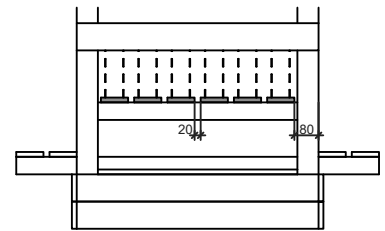

3a 3,2x5,8x130cm
x2

SD x4

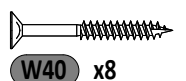
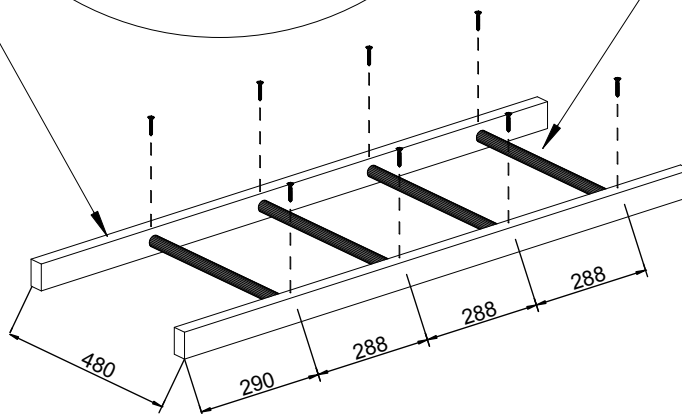
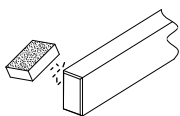

25

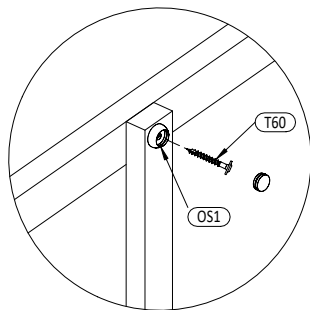
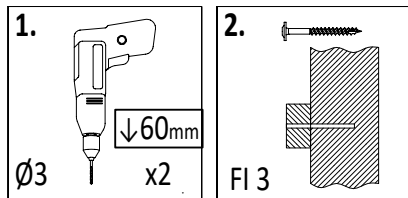

OS1 x2

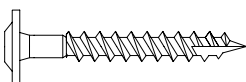

T60 x2

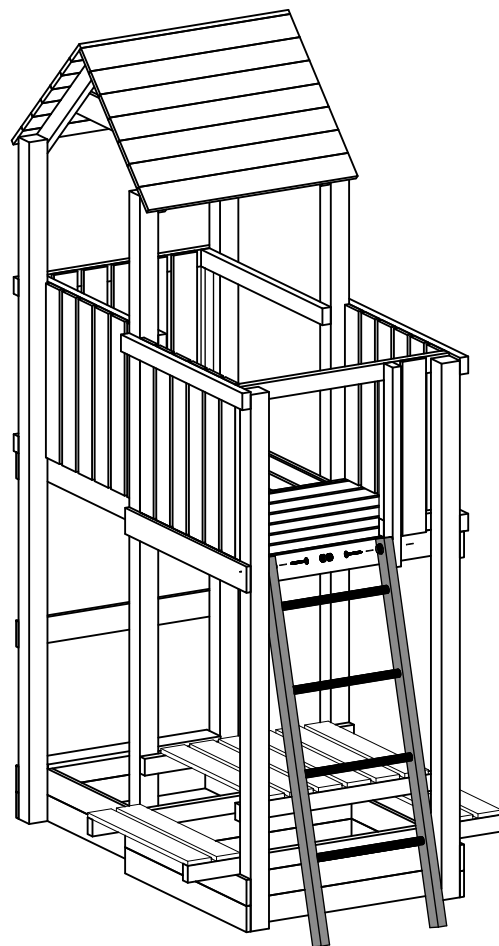

26

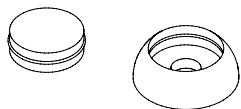
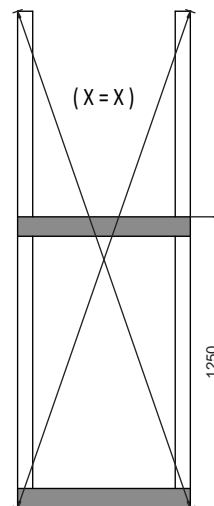
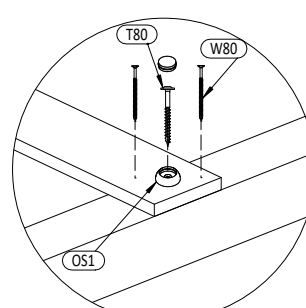
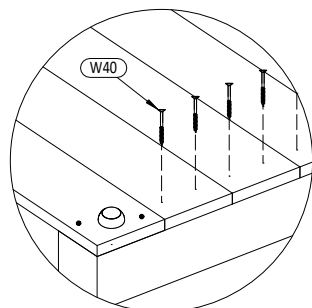
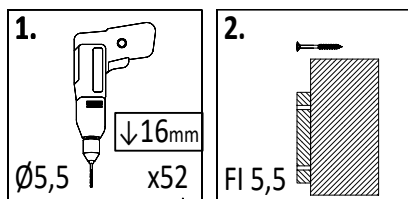
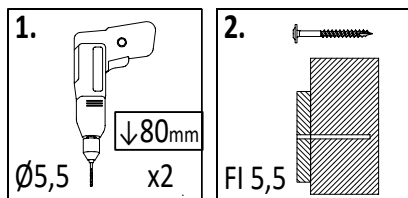

OS1 x4



W40 x52



W80 x4



T80 x4

18 1,6x9,0x80cm

!!!min 2mm < a < !!!max 6mm

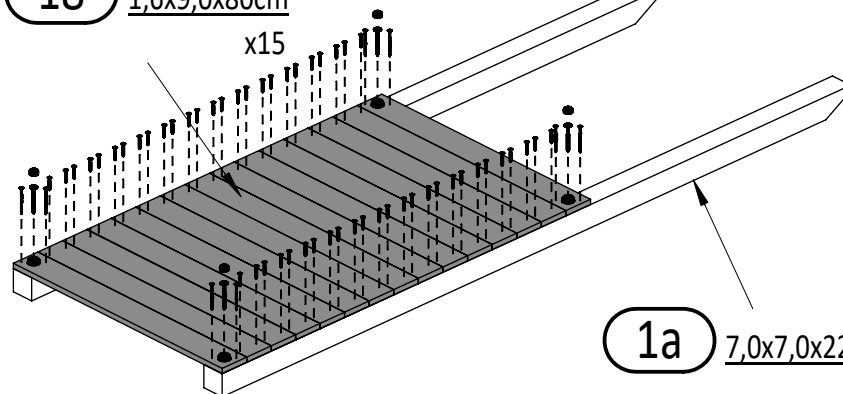

1a 7,0x7,0x220cm

x2

20 FLUPPI V2

Zgodnie z normą PN-EN 71 stosuj zalecenia producenta odnośnie odległości oraz metody mocowania poszczególnych elementów
In compliance with the standard PN-EN 71, apply guidelines of the producer in relation to distances and methods of fastening individual elements

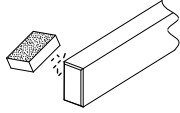
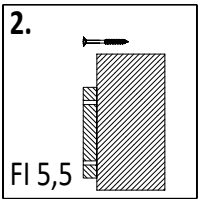
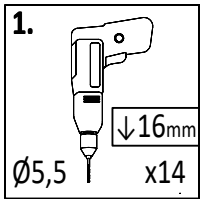

4 3,2x5,8x120cm
x1

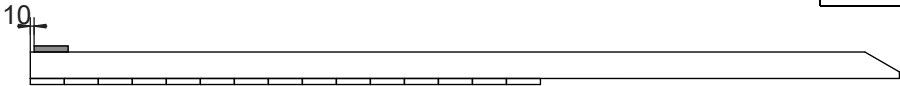
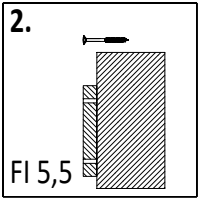
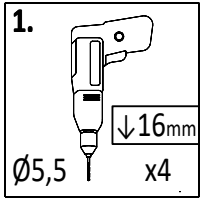
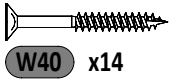
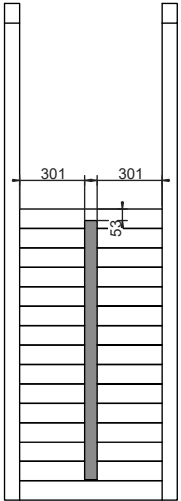
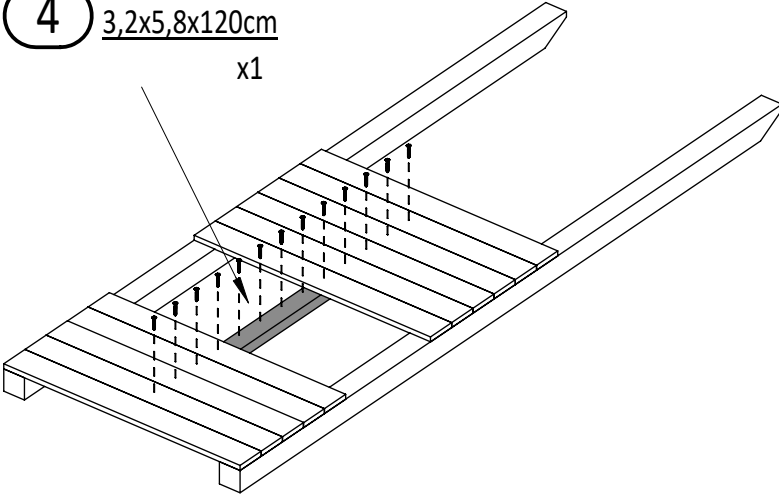

18 1,6x9,0x80cm
x1

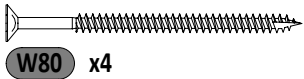
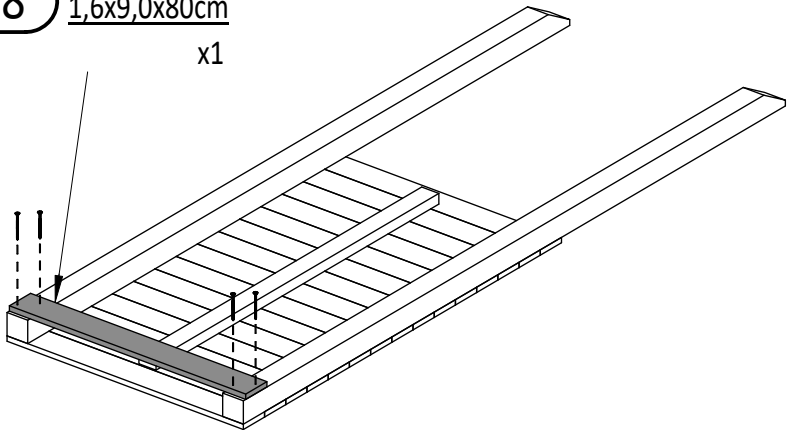
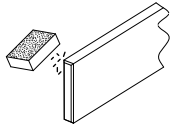

Zgodne z normą PN-EN 71 stosuj zalecenia producenta odnośnie odległości oraz metody mocowania poszczególnych elementów
 In compliance with the standard PN-EN 71, apply guidelines of the producer in relation to distances and methods of fastening individual elements

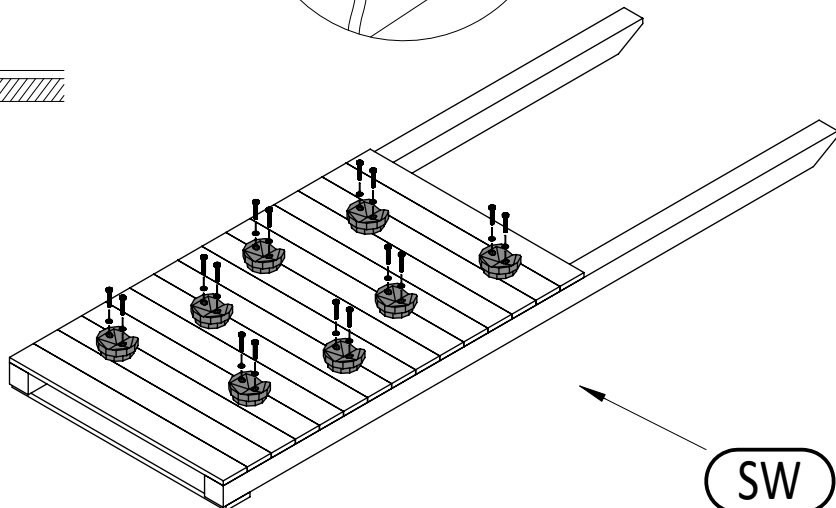
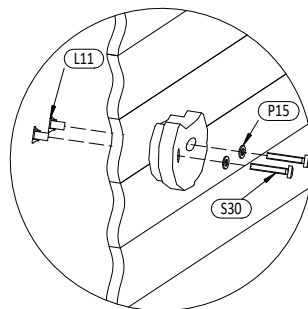
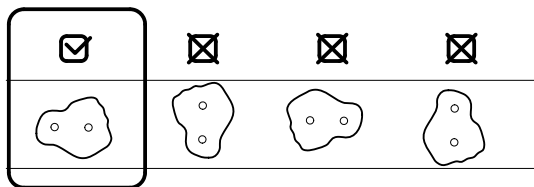
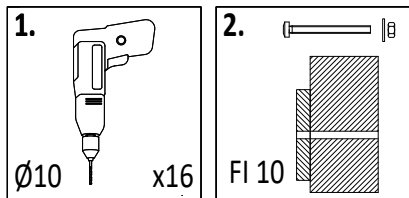

S30 x16



P15 x16



L11 x16

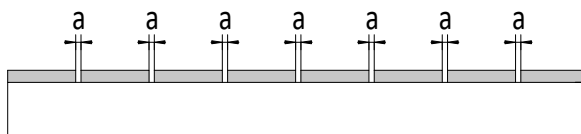
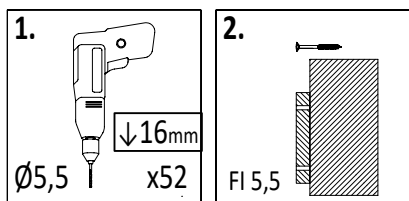
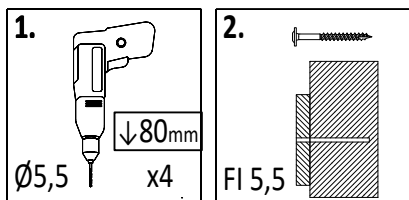

!!!min 2mm < a < !!!max 6mm

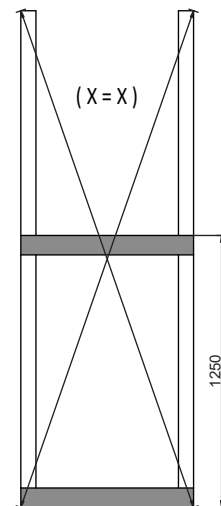

1a 7,0x7,0x220cm x2

18 1,6x9,0x80cm x12

18a 1,6x9,0x80cm x1



OS1 x4



W40 x52



W80 x10



T80 x4

6 3,2x5,8x80cm x3

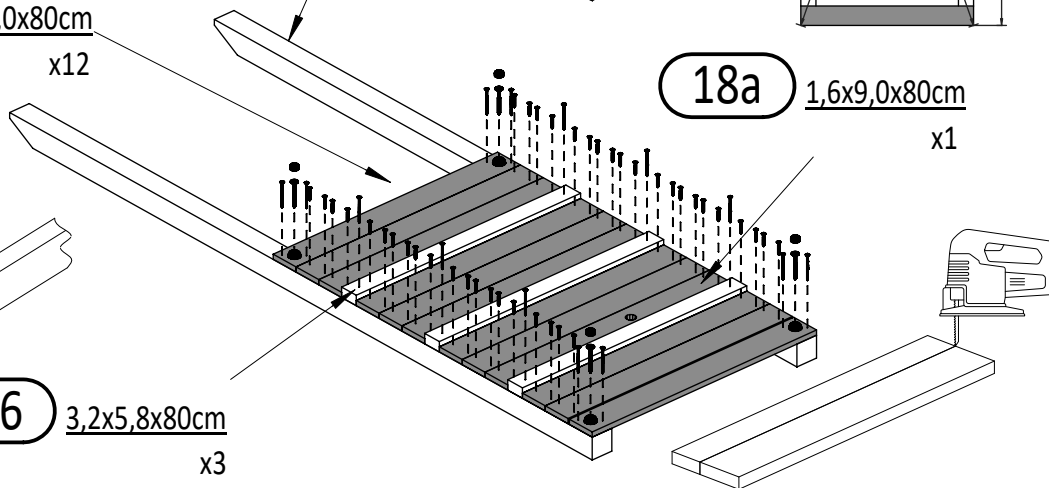

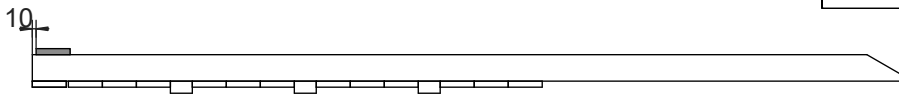
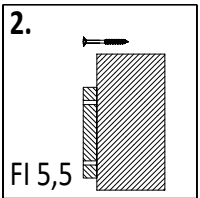
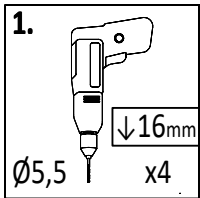

18 1,6x9,0x80cm
x1

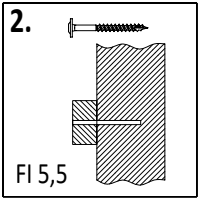
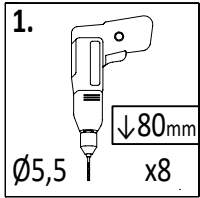
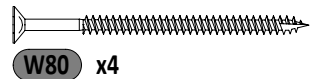
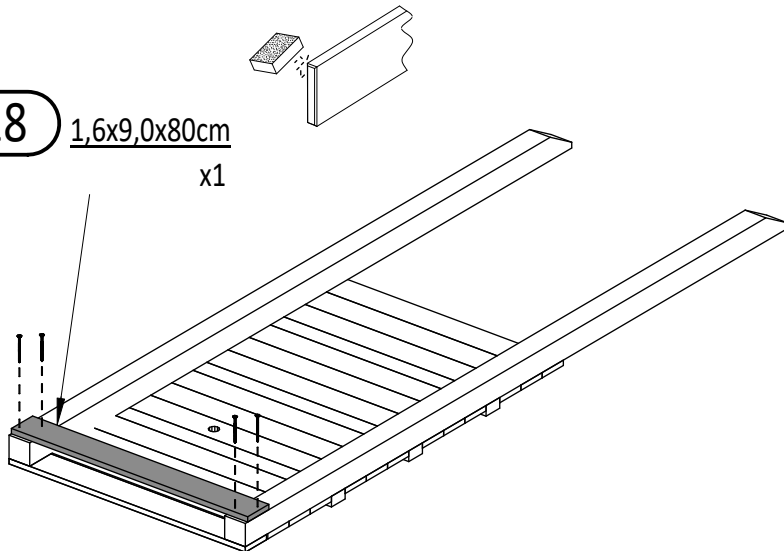

12a 3,2x5,8x30,0cm
x2

1b 7,0x14,0x220cm
x1

11a 3,2x5,8x36,7cm
x2

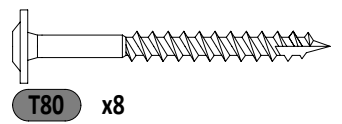
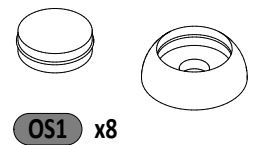
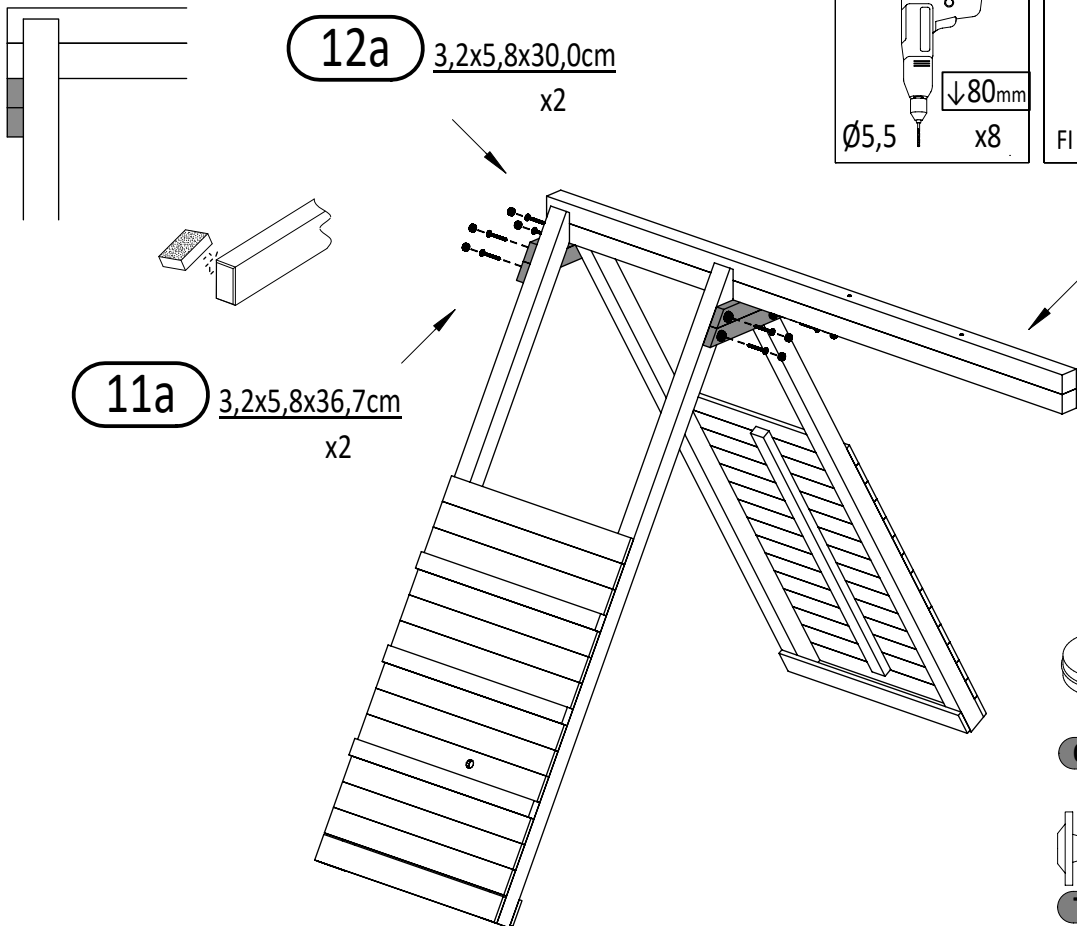

33

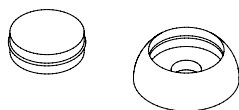
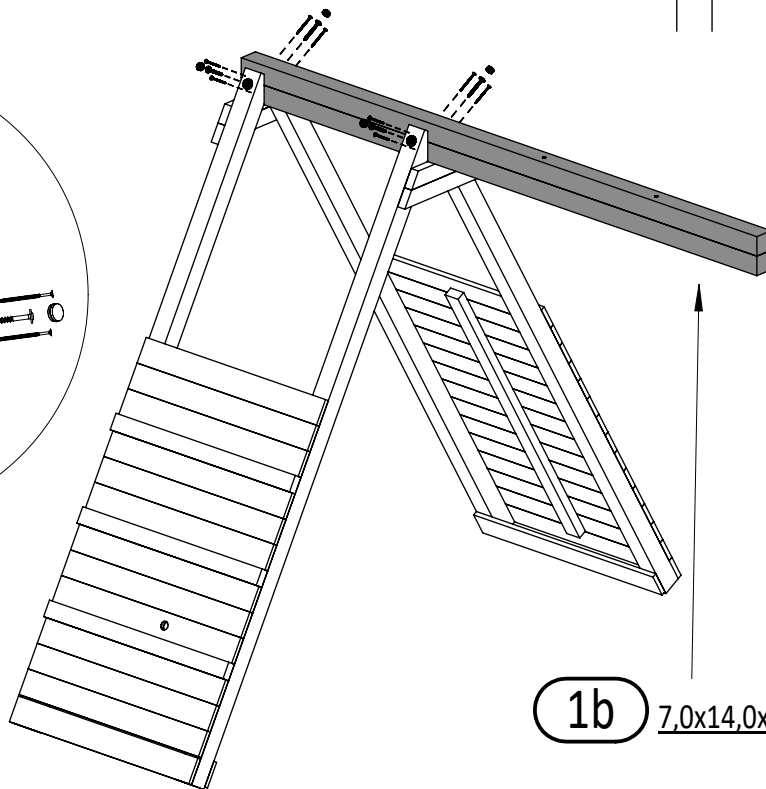
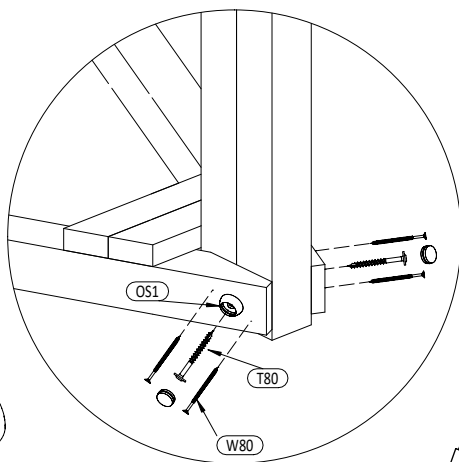
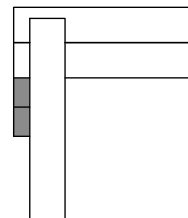
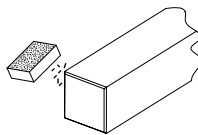
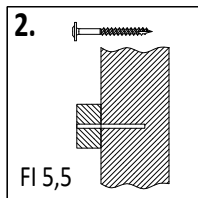
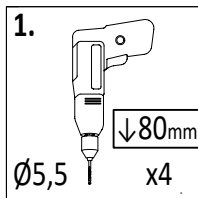

OS1 x4

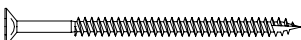

W80 x8

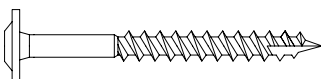

T80 x4

1b 7,0x14,0x220cm
x1

34

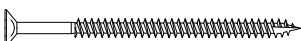
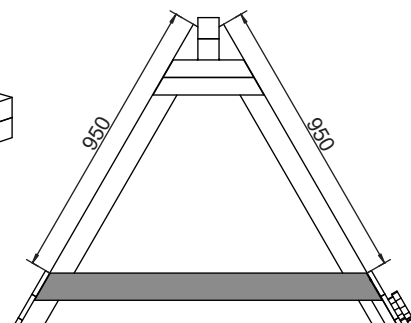
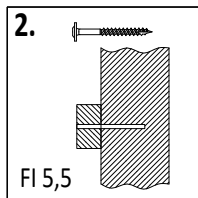
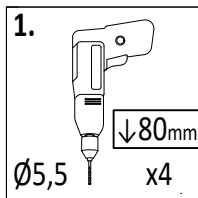

W80 x8

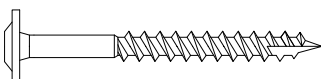



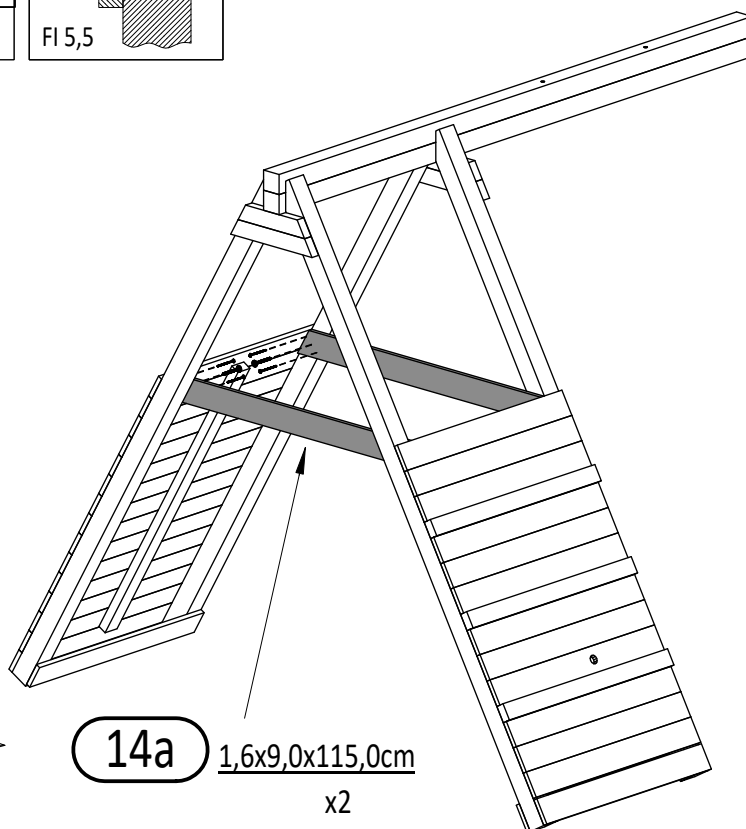



T80 x4

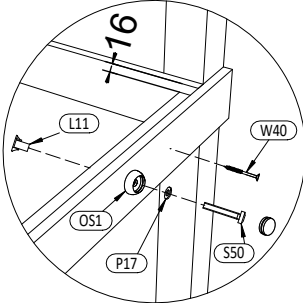
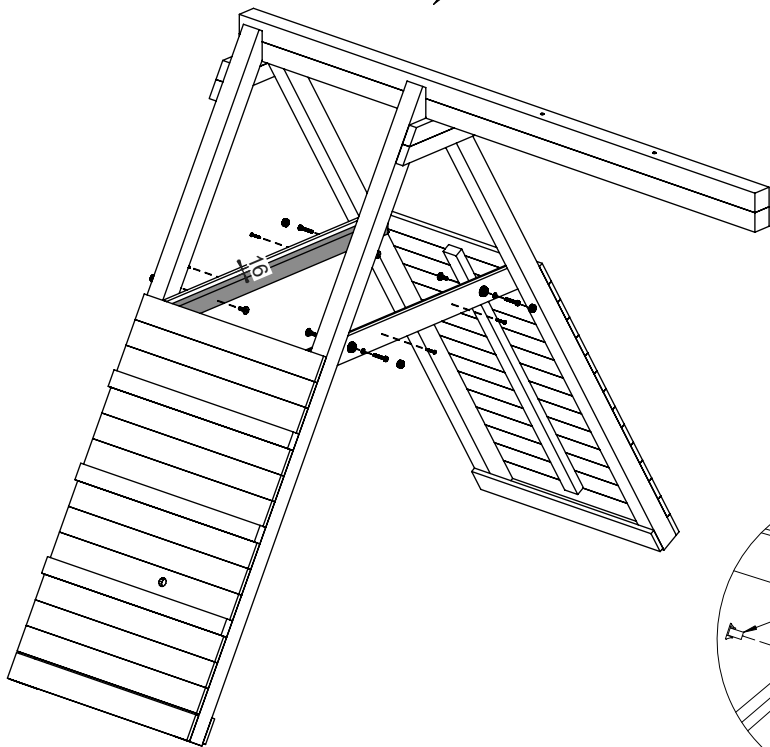
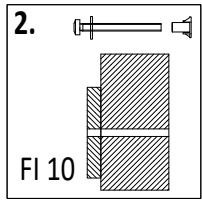
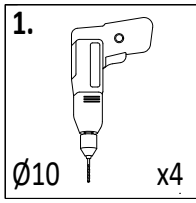

14a 1,6x9,0x115,0cm
x2

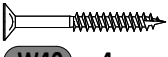
5 3,2x5,8x106,5cm x2



-  OS1 x4
-  W40 x4
-  S50 x4
-  P17 x4
-  L11 x4

5 3,2x5,8x106,5cm x1

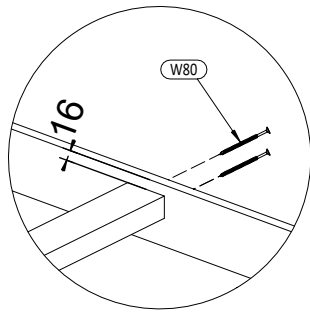
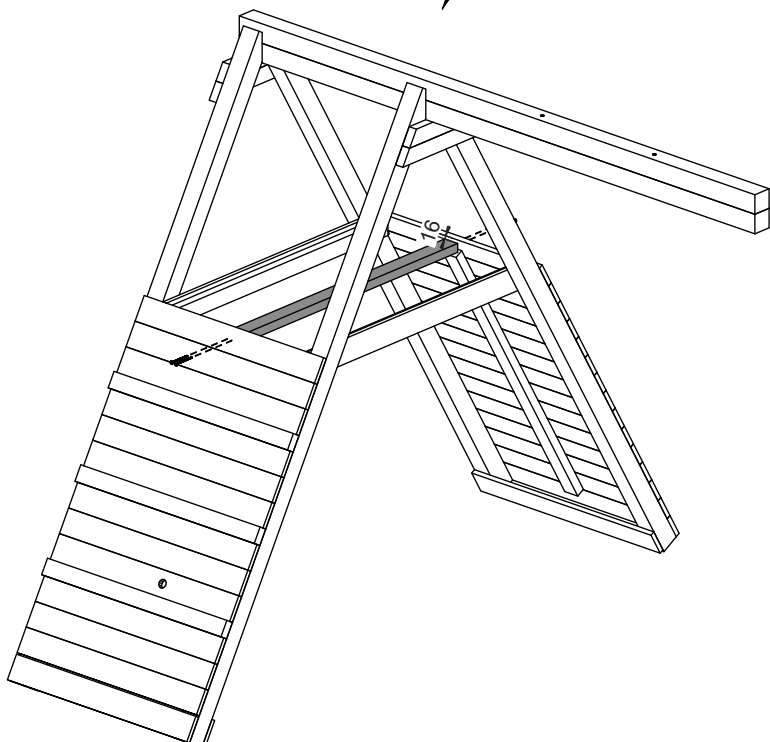

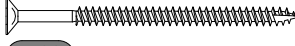
-  W80 x4

Zgodne z normą PN-EN 71 stosuj zalecenia producenta odnośnie odległości oraz metody mocowania poszczególnych elementów
 In compliance with the standard PN-EN 71, apply guidelines of the producer in relation to distances and methods of fastening individual elements

37

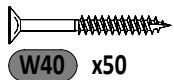
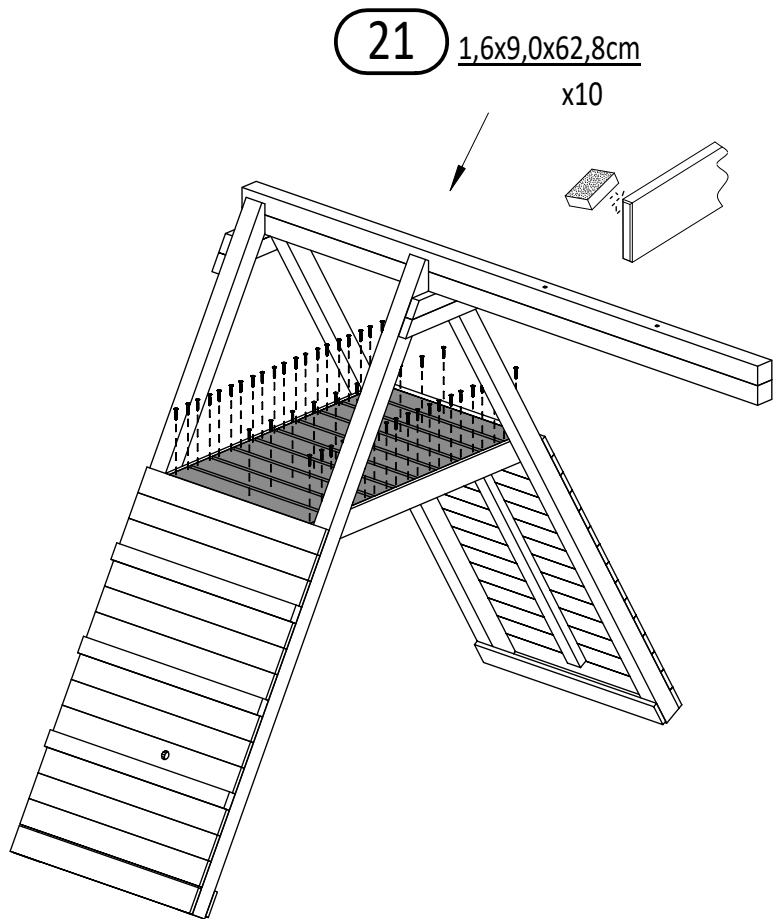
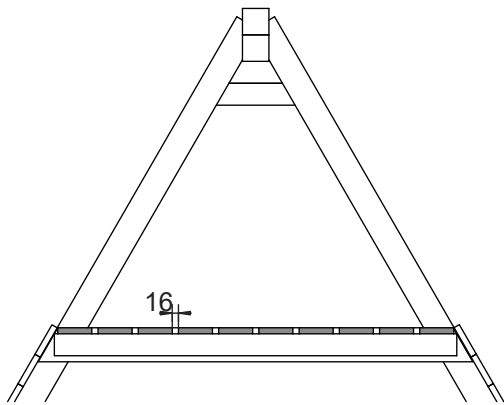
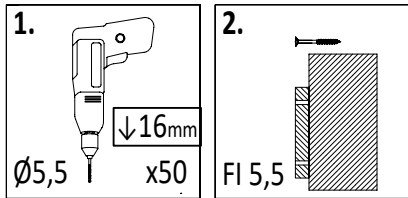

W40 x50

38

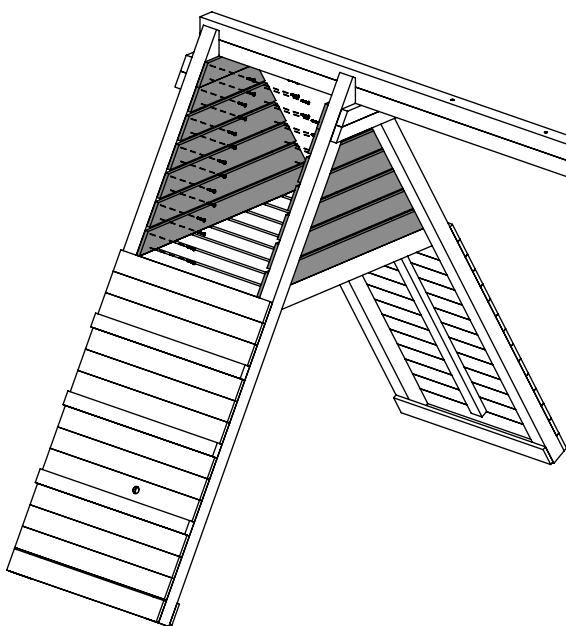
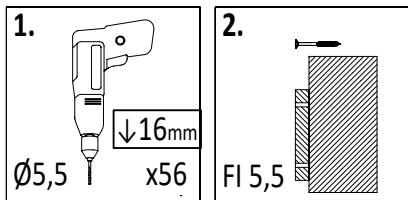

- 26a 1,6x9,0x34,0cm x2
- 25a 1,6x9,0x44,0cm x2
- 23a 1,6x9,0x56,5cm x2
- 19a 1,6x9,0x68,5cm x2
- 17a 1,6x9,0x80,5cm x2
- 16a 1,6x9,0x92,5cm x2
- 15a 1,6x9,0x105,0cm x2

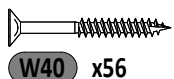
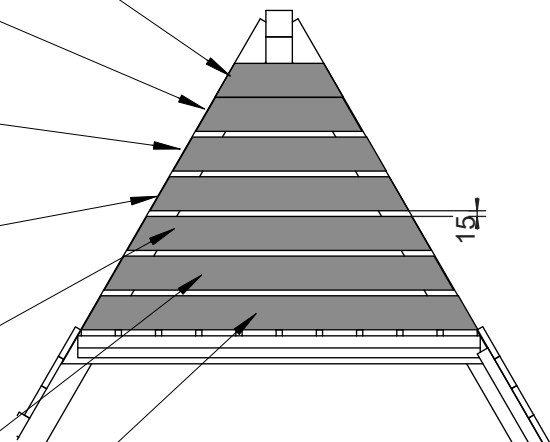
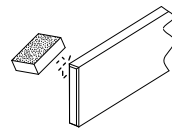

W40 x56

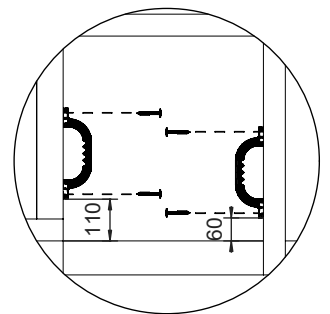
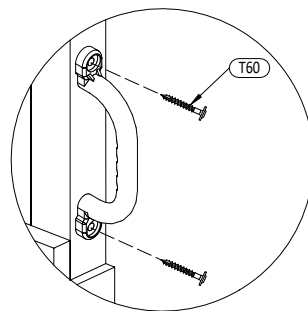
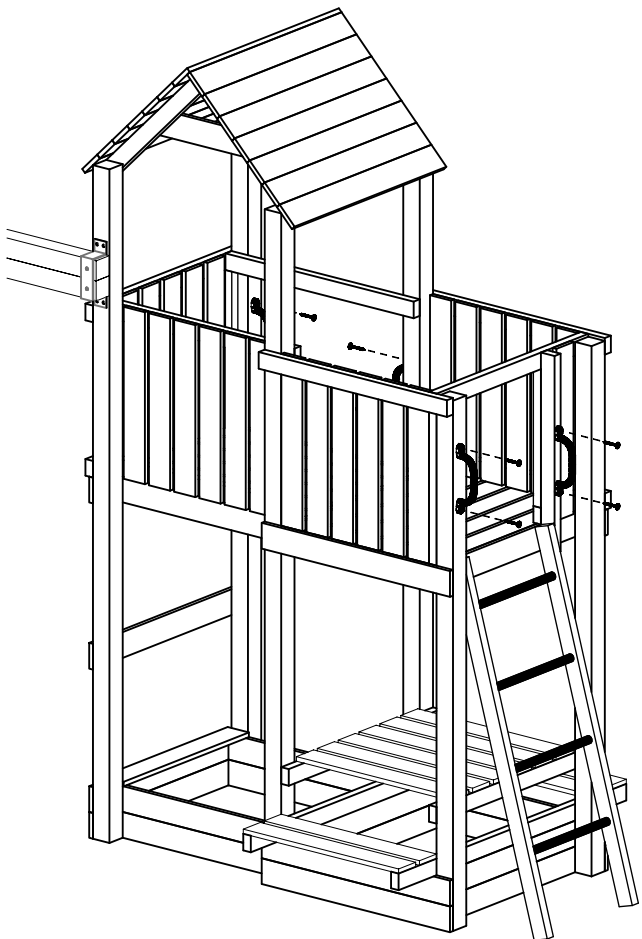
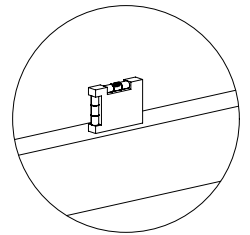
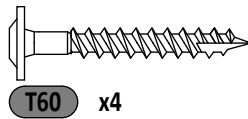
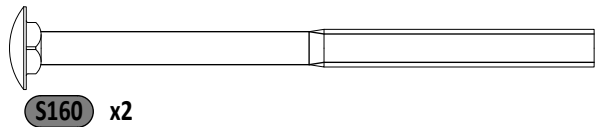
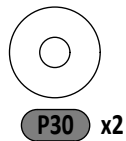
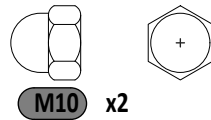
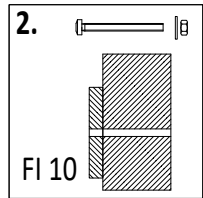
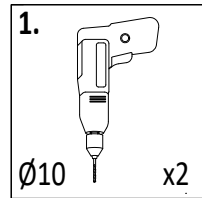
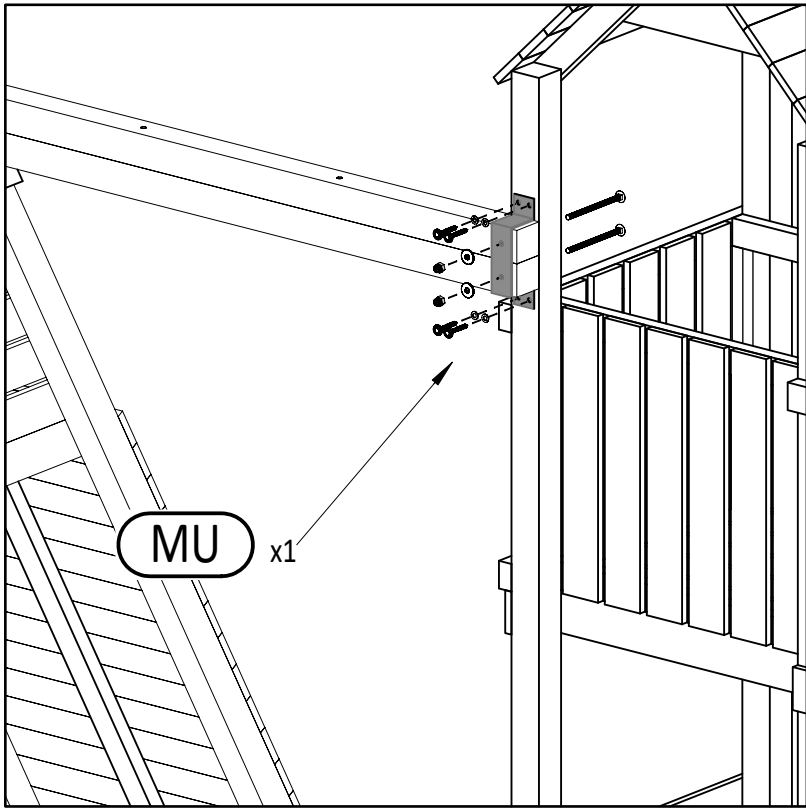

UC x4

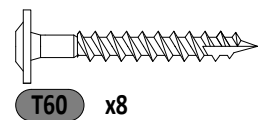

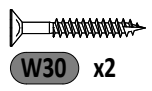
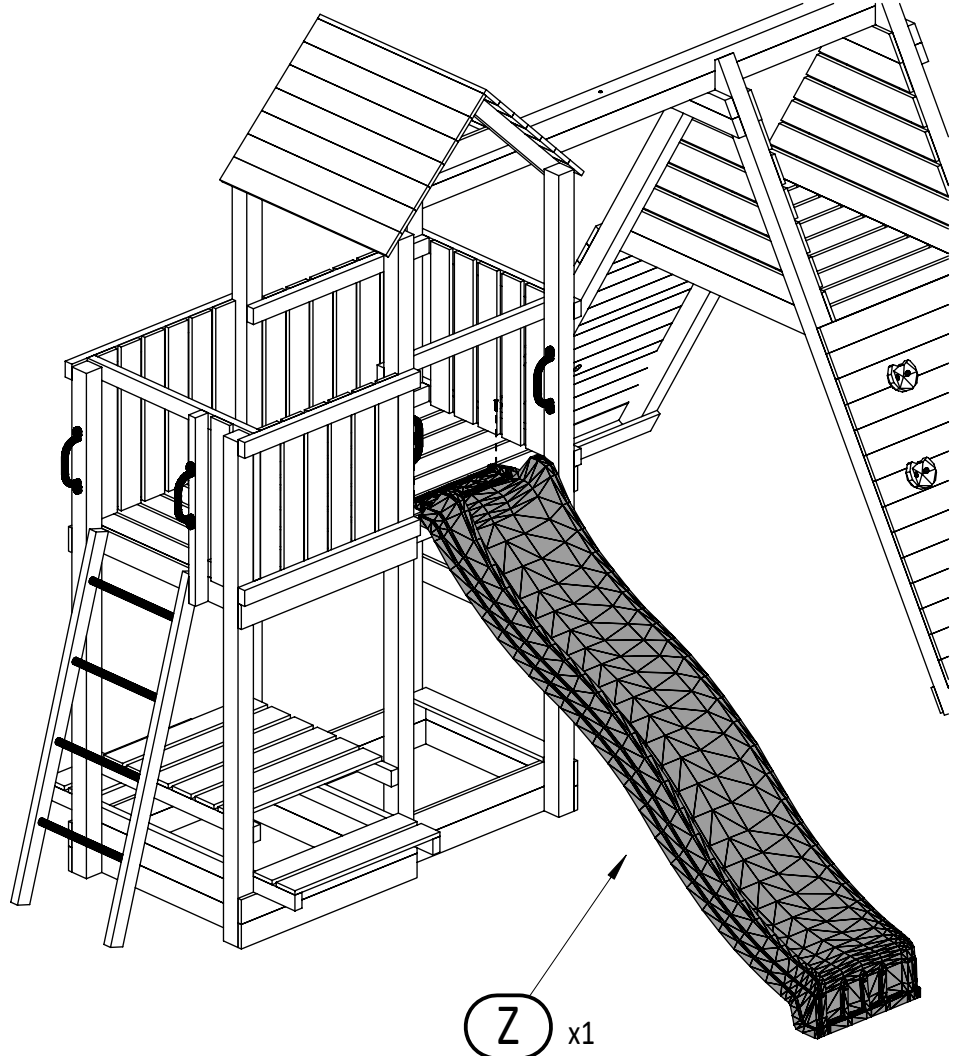
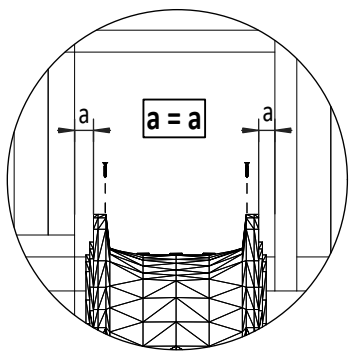

Z x1

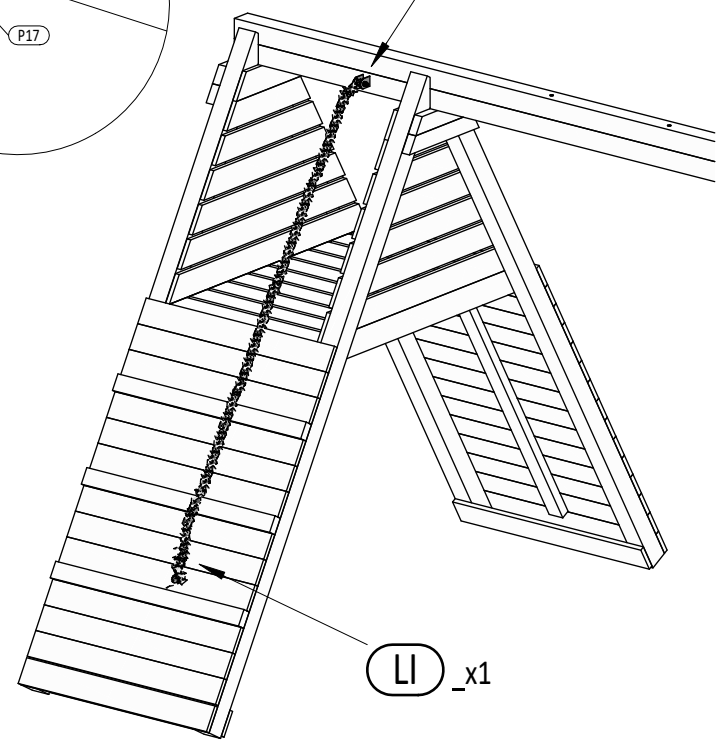
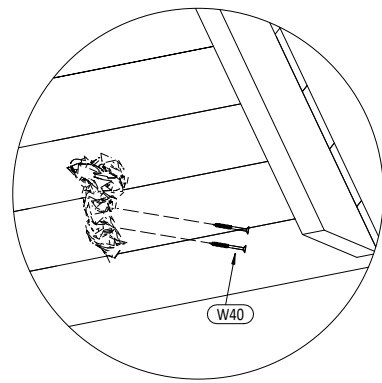
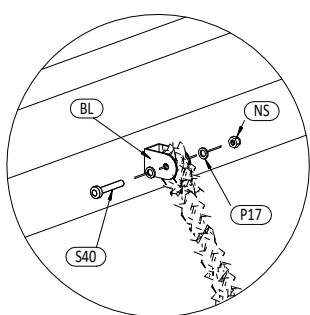
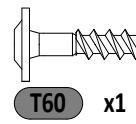
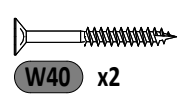
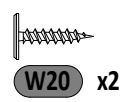
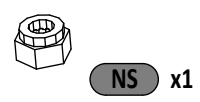
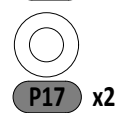
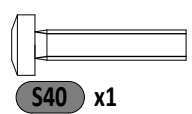
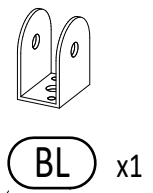
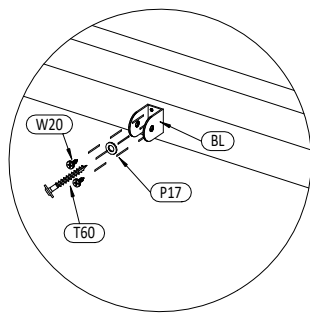
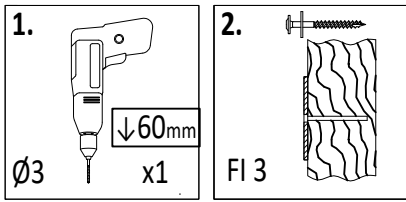

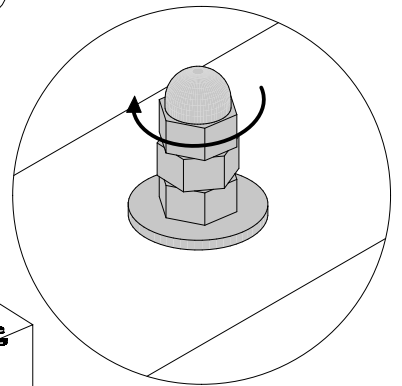
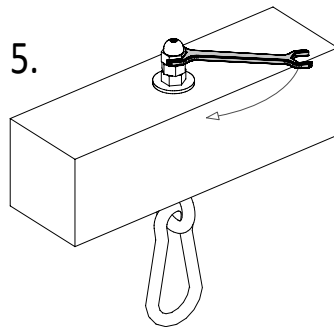
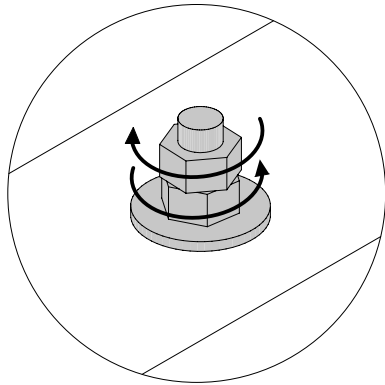
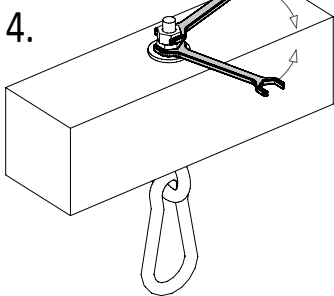
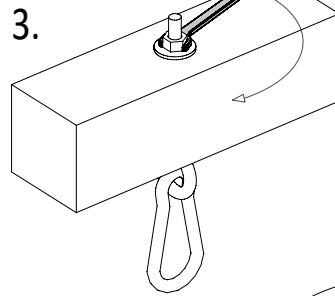
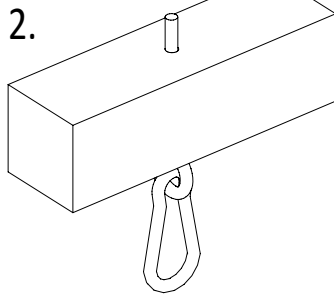
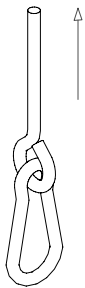
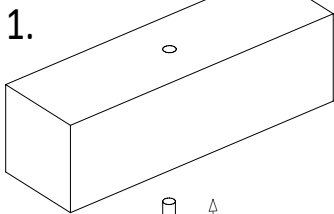
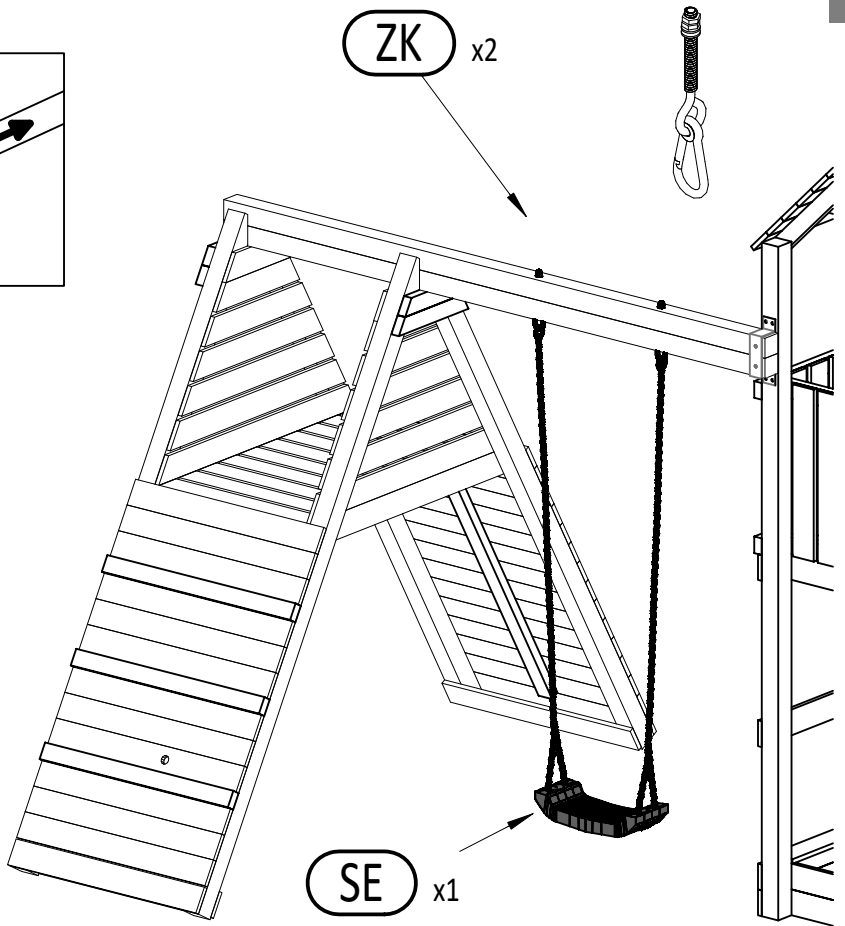
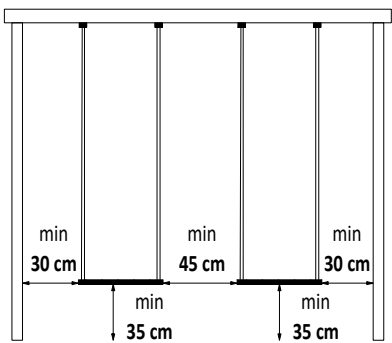
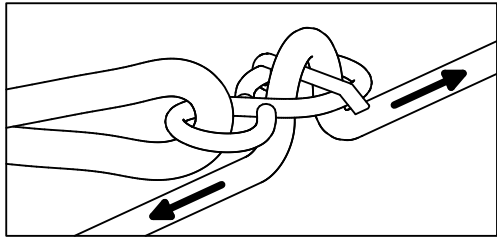

M12 x2

Zgodne z normą PN-EN 71 stosuj zalecenia producenta odnośnie odległości oraz metody mocowania poszczególnych elementów
 In compliance with the standard PN-EN 71, apply guidelines of the producer in relation to distances and methods of fastening individual elements

45

DW

x1

TS

x1

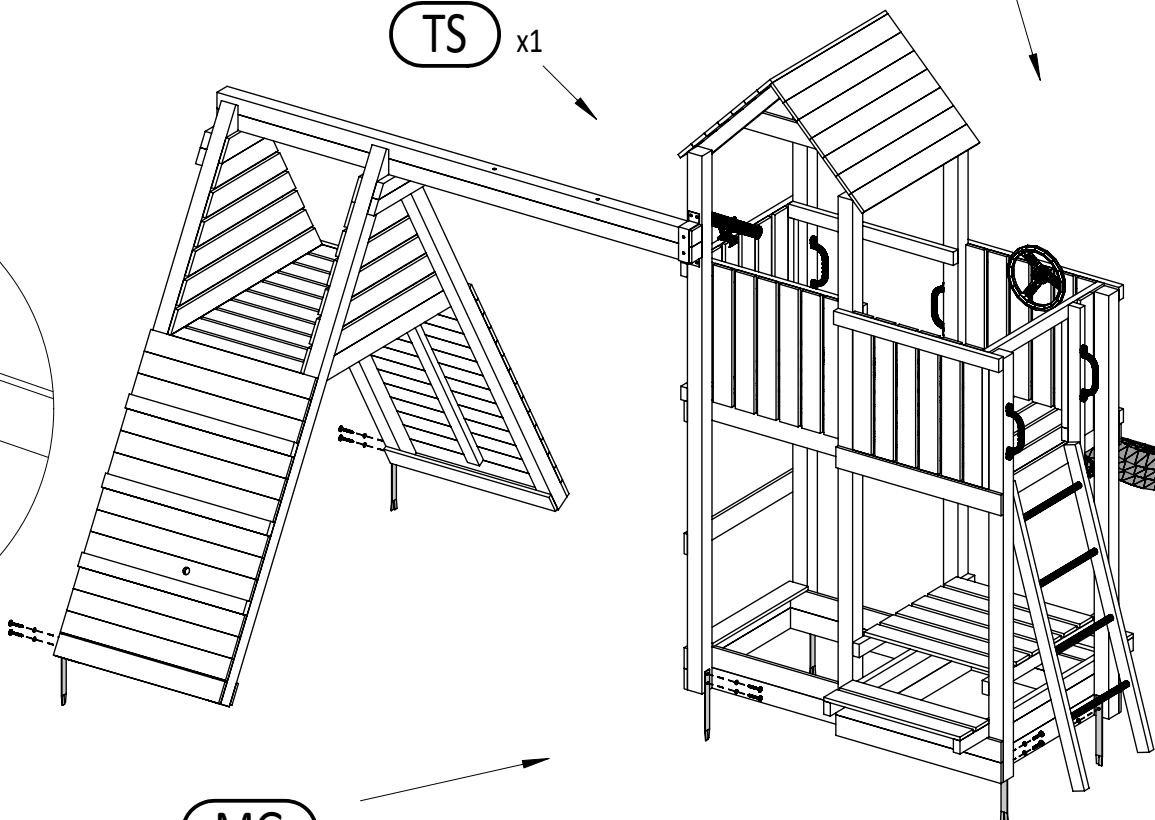
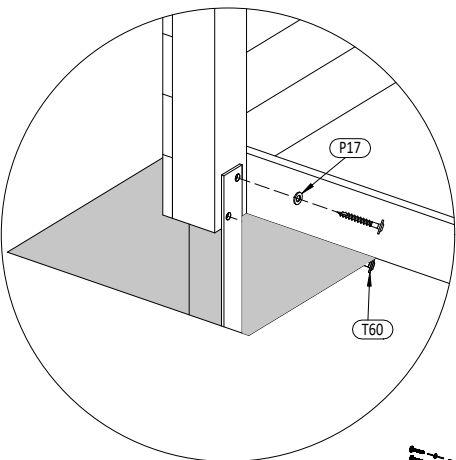

MG

x6



P17 x12

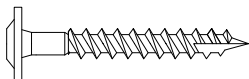

T60 x12

46

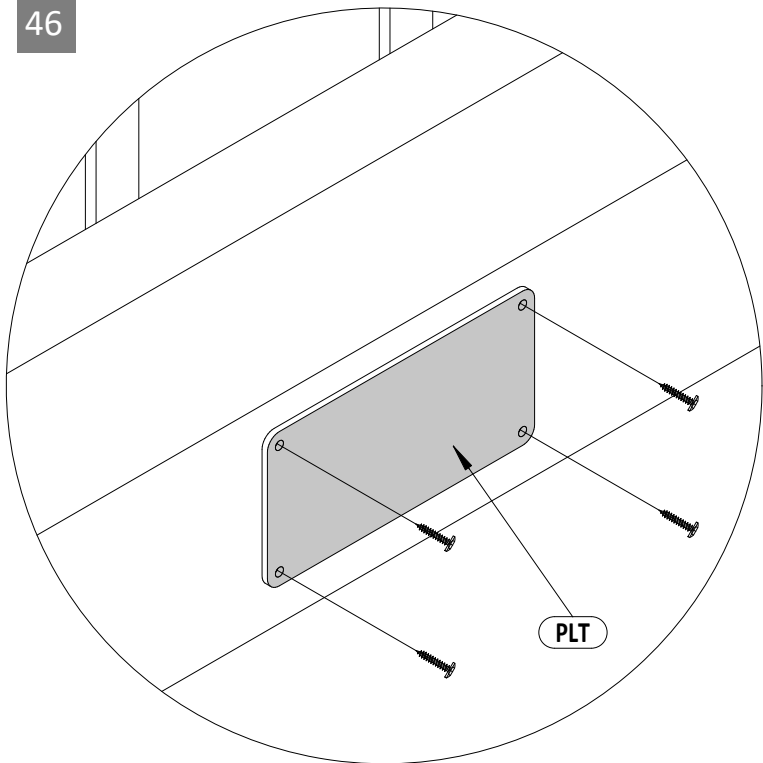

PLT

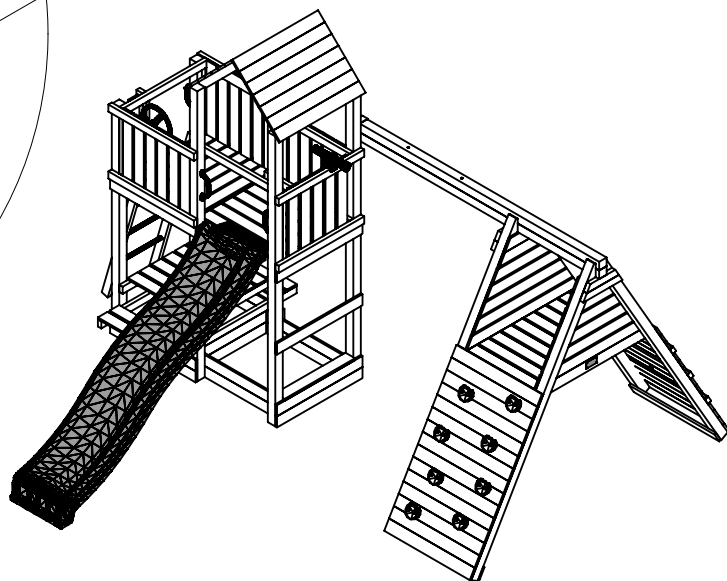

W20 x4