

# PLAYGROUND SPIELPLATZ

# GIOCO AIRE DE JEUX

(385 x 410 x h262cm)

003\_08800\_10102024

## FLEPPI V2

INSTALLATION INSTRUCTIONS  
MONTAGEANLEITUNG

ISTRUZIONI DI MONTAGGIO  
GUIDE D'INSTALLATION

Warranty period - 2 years from purchase date

Garantiezeit - 2 Jahre ab Kaufdatum

Periodo di garanzia - 2 anni dalla data di acquisto

Période de garantie - 2 ans à compter de l'achat

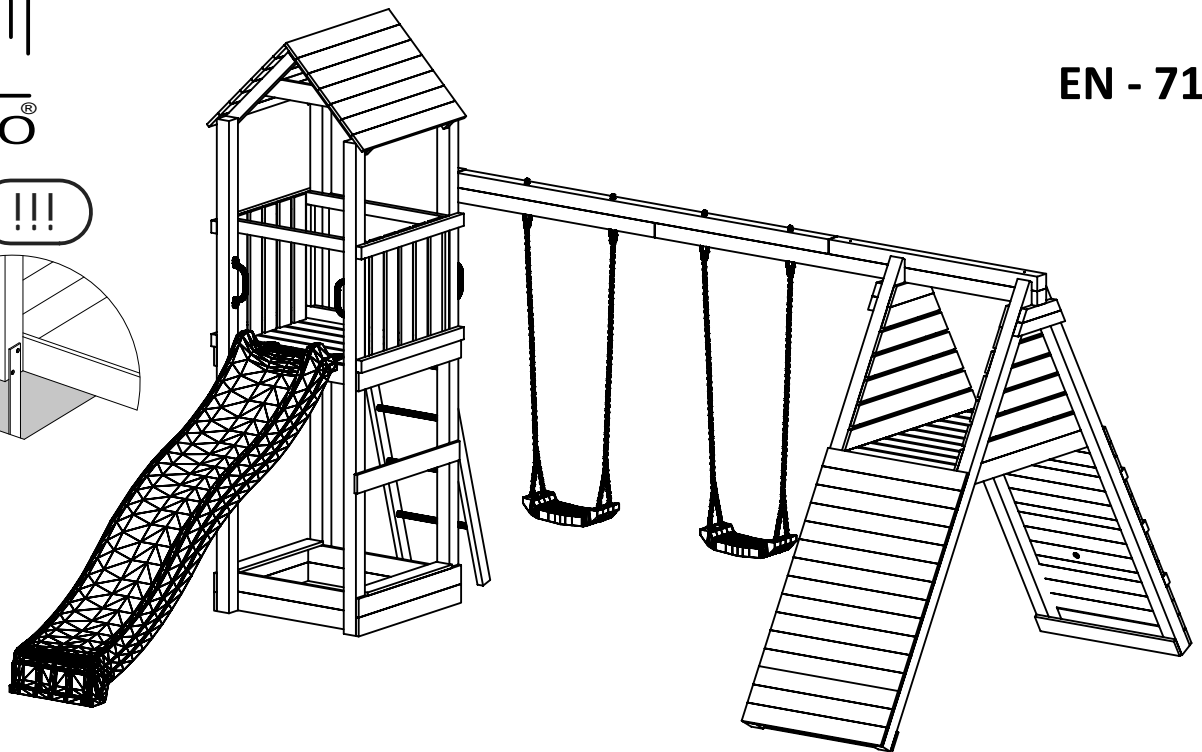
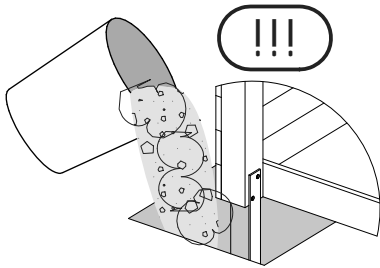

EN - 71

### WARNINGS!

Only for home use.

Dedicated for external use only.

Not suitable for children under 3 years old.

Risk of falling down and/or hitting.

Maximum user weight is up to 50 kg.

Maximum number of users staying on the  
playground at the same time: 9.

### ATTENZIONE!

Solo per uso domestico.

Articolo per uso esterno.

Previsto per bambini di età superiore ai 3 anni.

Pericolo di caduta, e/o impatto.

Peso massimo di utente : 50kg

Numero massimo di utilizzatori  
del gioco nello stesso momento: 9.

### ACHTUNG!

Nur für den privaten, häuslichen Bereich.

Ausschließlich für die Verwendung im Freien.

Nicht geeignet für Kinder unter 3 Jahren.

Stolper- und / oder Sturzgefahr

Höchstgewicht pro Einzelkind beträgt 50 kg

Der Aufenthalt auf diesem Spielturm ist max. : 9.

Kindern gleichzeitig erlaubt.

### AVERTISSEMENT!

Aire exclusivement destinée à un usage privé.

Aire exclusivement destinée à un usage en extérieur.

Prévue pour les enfants de plus de 3 ans.

Danger de chute ou de choc.

Poids maximal d'un utilisateur : 50 kg.

Nombre maximal d'utilisateurs présents en  
même temps sur la même aire de jeux: 9.

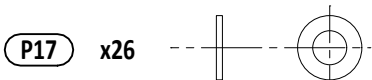
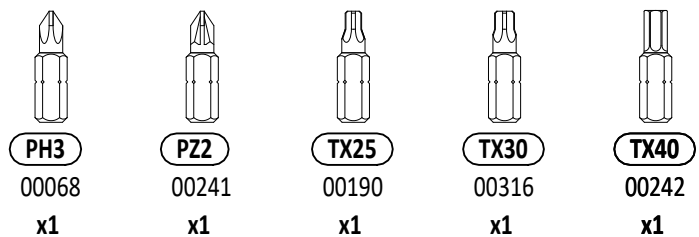
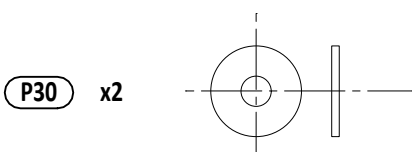
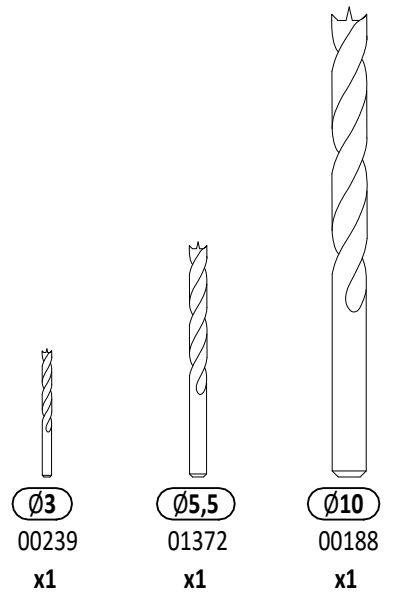
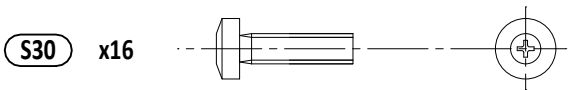
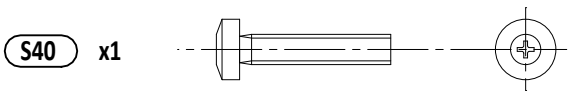
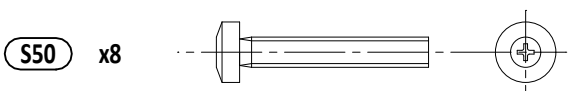
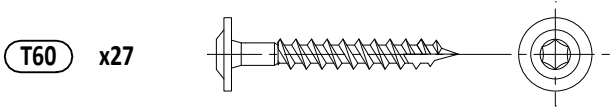
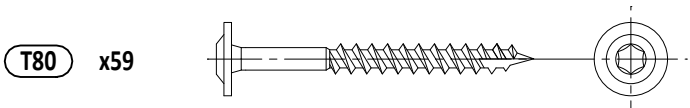
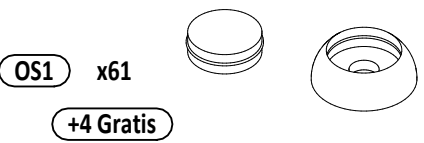
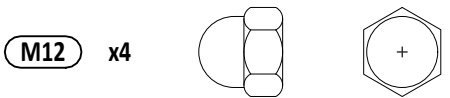
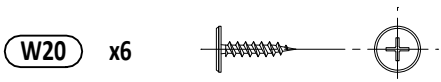
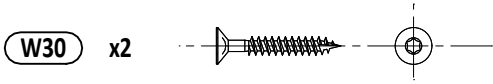
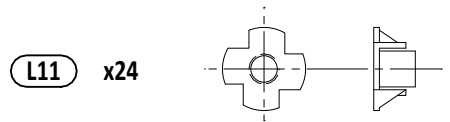
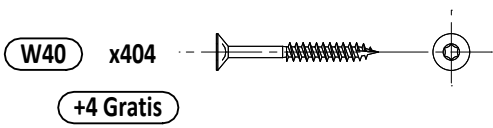
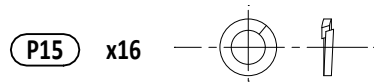
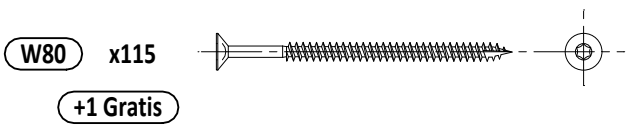

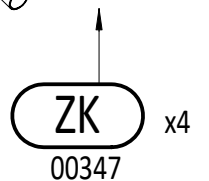
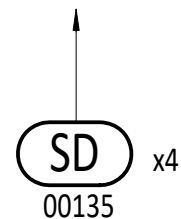
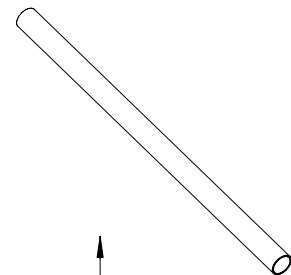
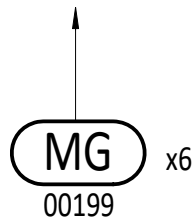
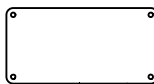
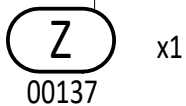
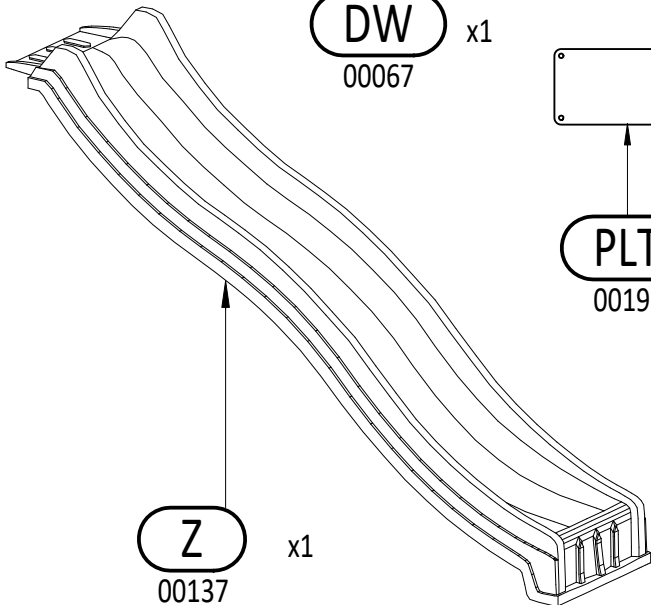
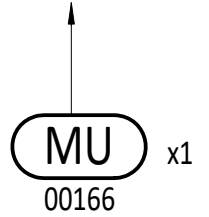
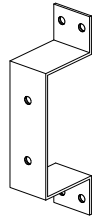
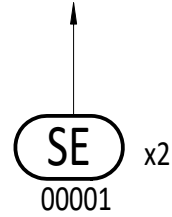
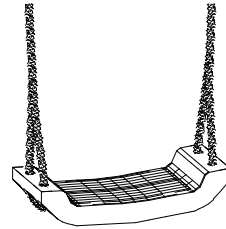
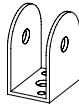
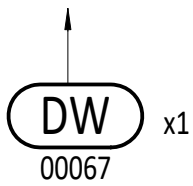
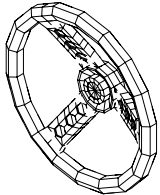
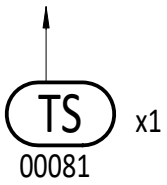
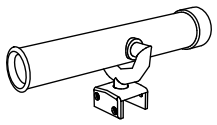
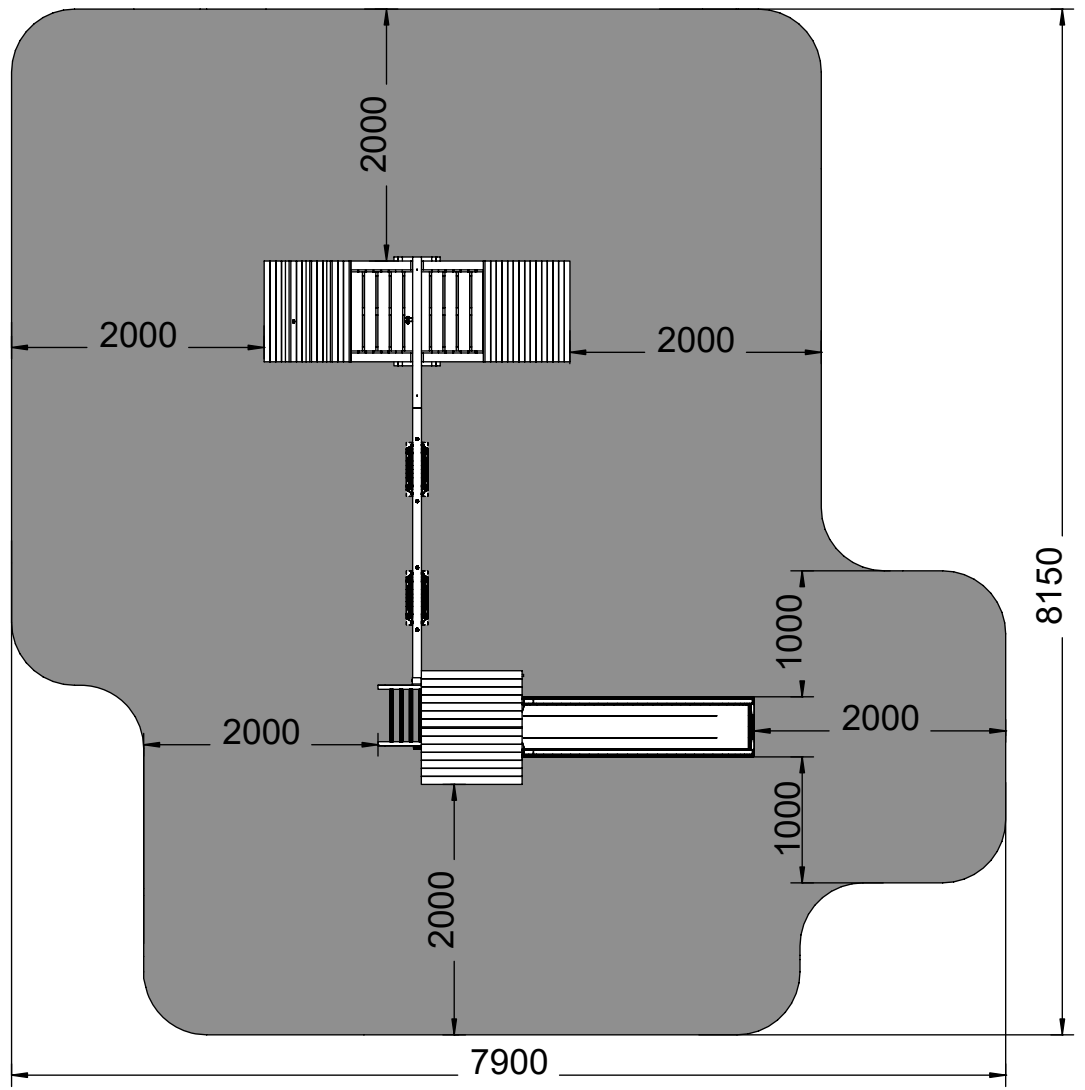
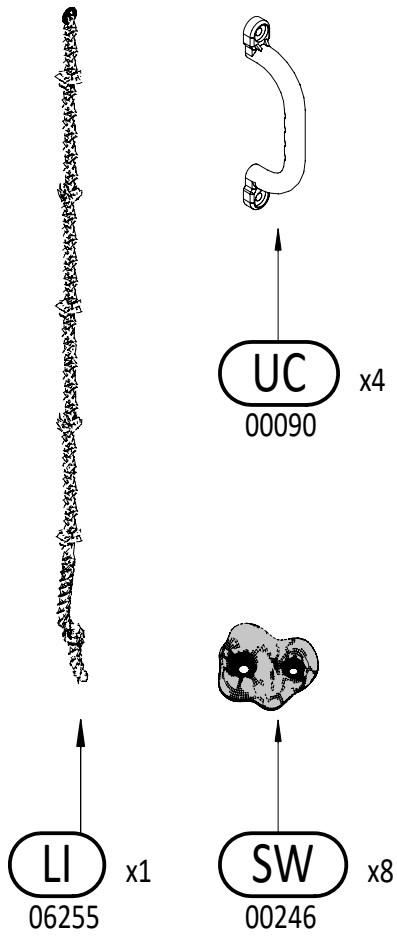

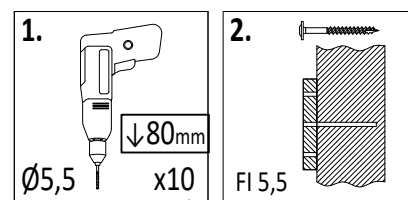
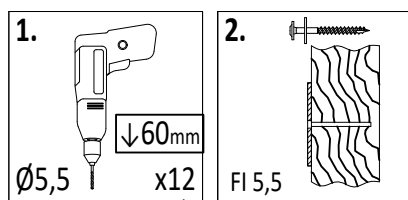
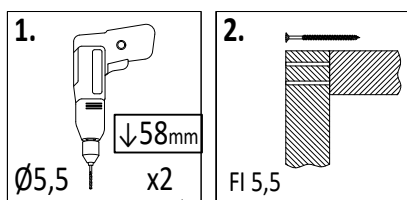
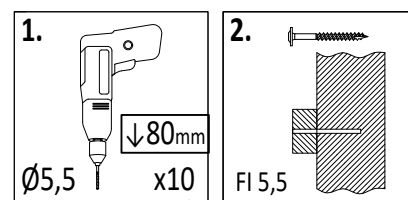
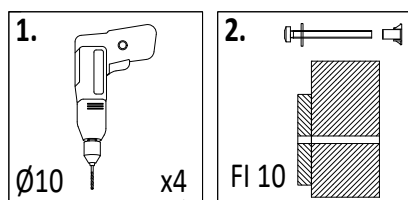
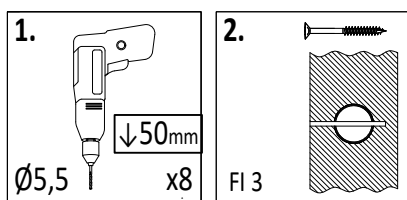
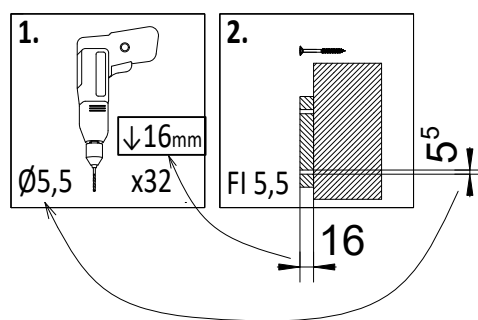
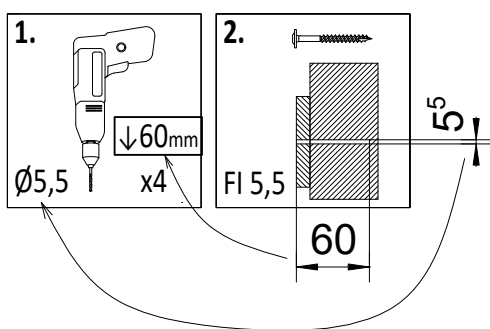
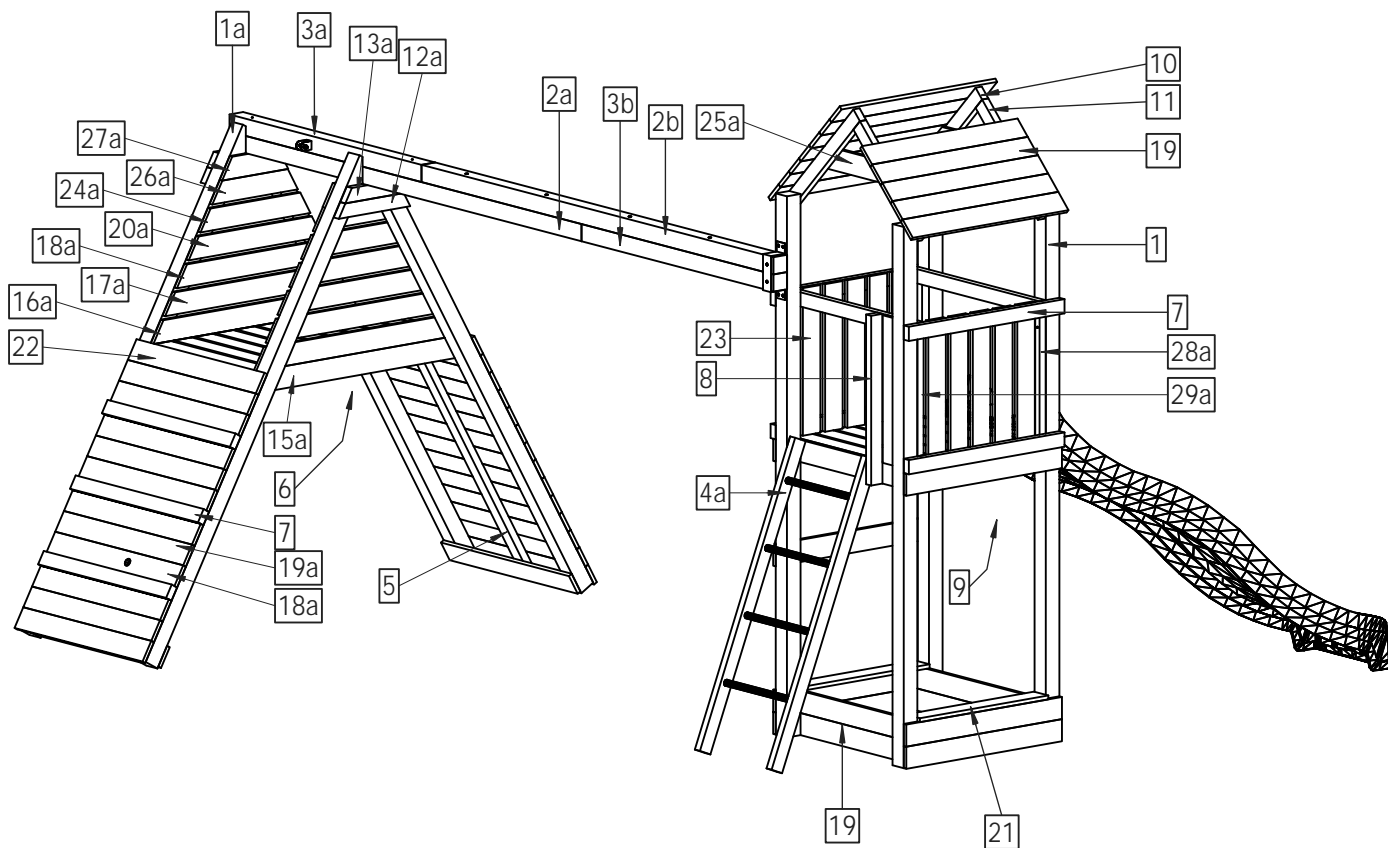

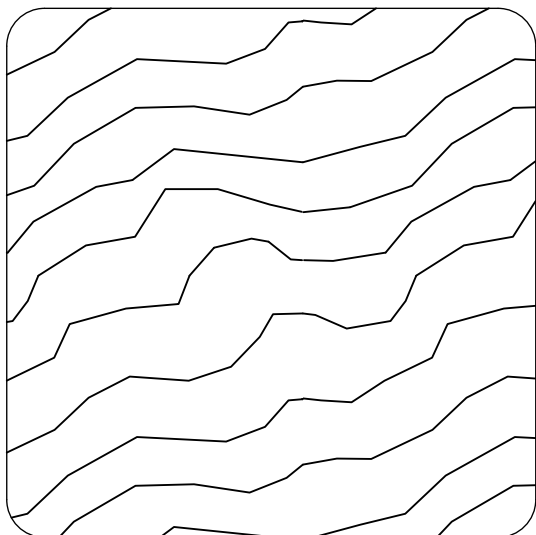

**7,0 x 7,0 cm**

Lp.	Kod	Wymiary [mm]	szk.
1	03901	70x70x2200mm	4
1a	08457	70x70x2200mm	4
2a	03991	70x70x2200mm	1
2b	03993	70x70x2200mm	1
3a	03995	70x70x1200mm	1
3b	03946	70x70x1200mm	1



**1,6 x 9,0 cm**

Lp.	Kod	Wymiary [mm]	szk.
15a	04916	16x90x1150mm	2
16a	04918	16x90x1050mm	2
17a	04920	16x90x925mm	2
18a	04922	16x90x805mm	2
19	04465	16x90x800mm	63
19a	04393	16x90x800mm	1
20a	04924	16x90x685mm	2
21	04096	16x90x660mm	2
22	04914	16x90x628mm	10
23	04625	16x90x600mm	11
24a	04926	16x90x565mm	2
25a	04467	16x90x560mm	2
26a	04928	16x90x440mm	2
27a	04930	16x90x340mm	2

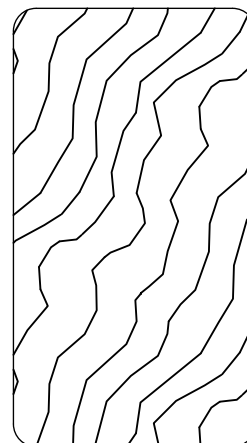

**3,2 x 5,8 cm**

Lp.	Kod	Wymiary [mm]	szk.
4a	04613	32x58x1300mm	2
5	03889	32x58x1200mm	1
6	04906	32x58x1065mm	3
7	04457	32x58x800mm	9
8	04615	32x58x690mm	1
9	04459	32x58x628mm	3
10	04617	32x58x610mm	2
11	04619	32x58x550mm	2
12a	04908	32x58x367mm	2
13a	04910	32x58x300mm	2
14	04621	32x58x250mm	1

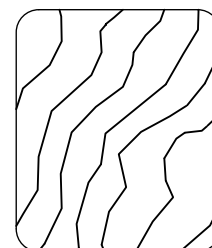

**2,7 x 3,2 cm**

Lp.	Kod	Wymiary [mm]	szk.
28a	04471	27x32x542mm	3
29a	04476	27x32x484mm	1

1

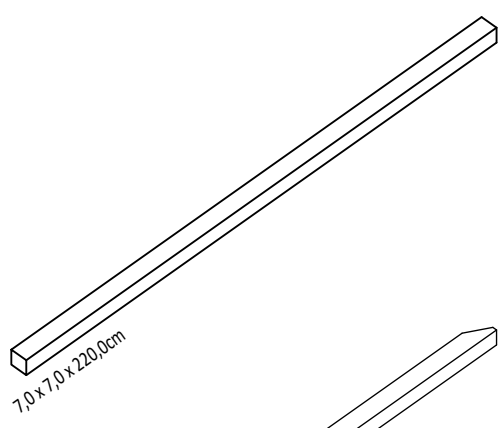

1a

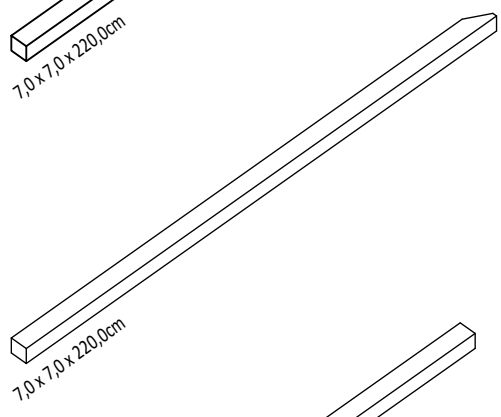

2a

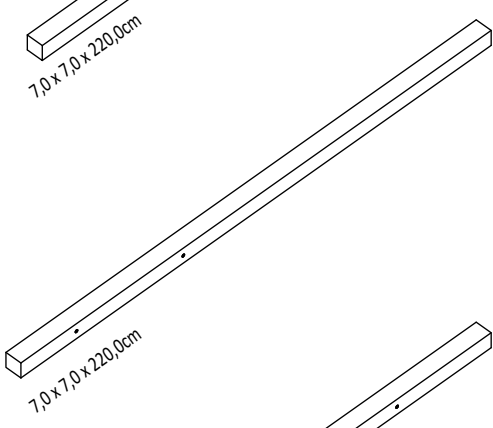

2b

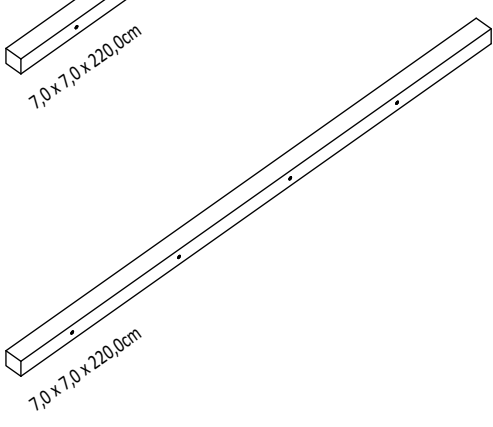

3a

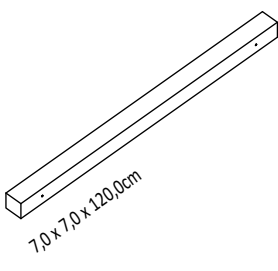

3b

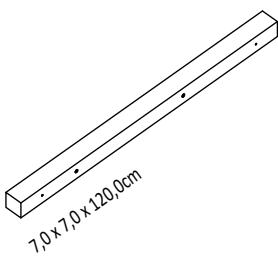

4a

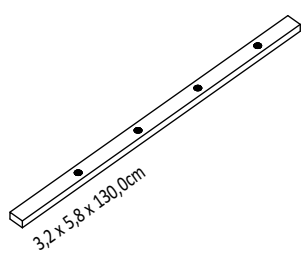

5

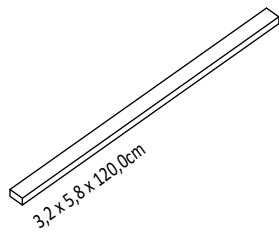

6

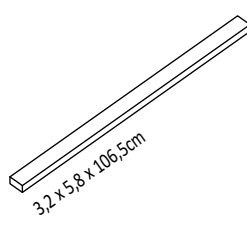

7

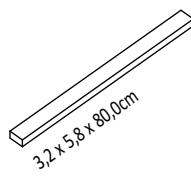

11

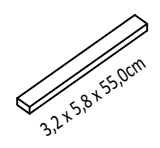

8

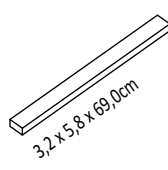

12a

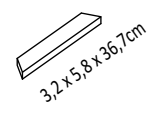

9

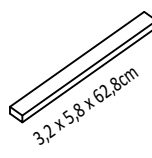

13a

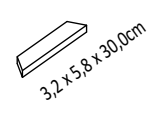

10

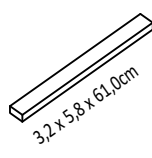

14

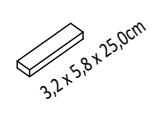

15a

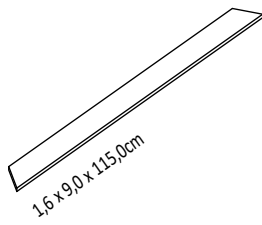

21

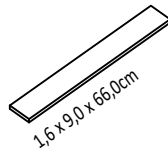

16a

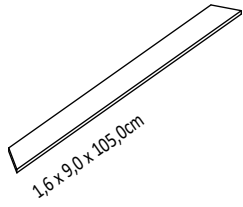

22

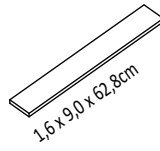

17a

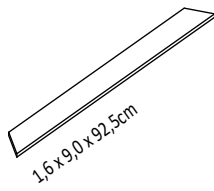

23

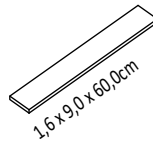

18a

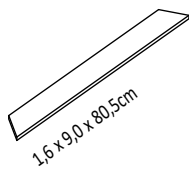

24a

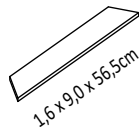

19

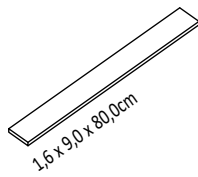

25a

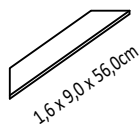

19a

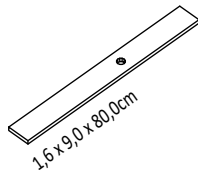

26a

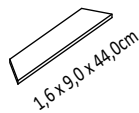

28a

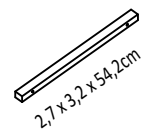

20a

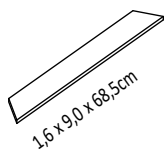

27a

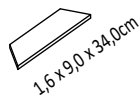

29a

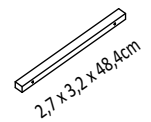

01

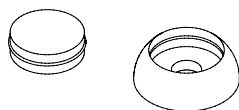
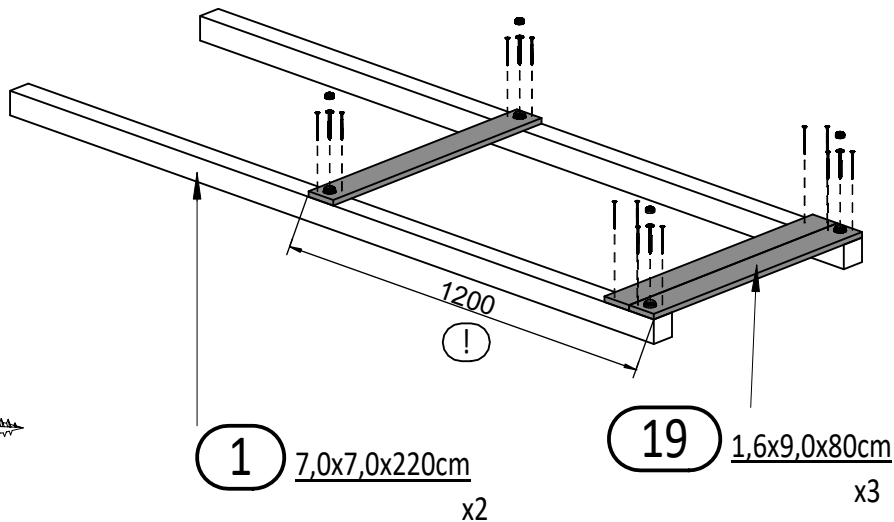
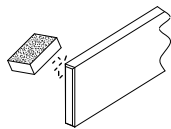
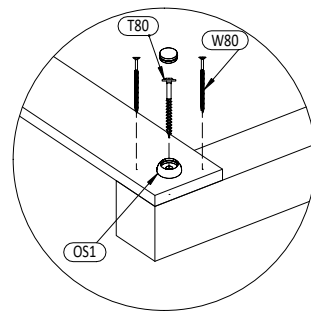
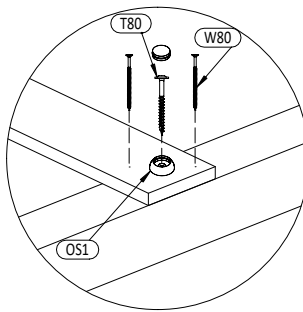
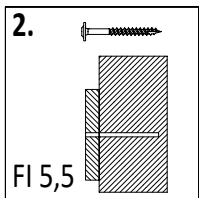
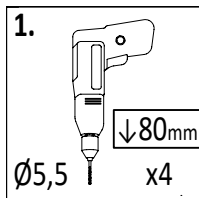

OS1 x4



W80 x12



T80 x4

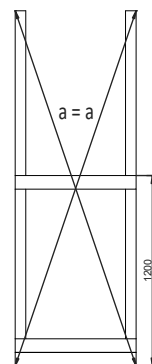

02

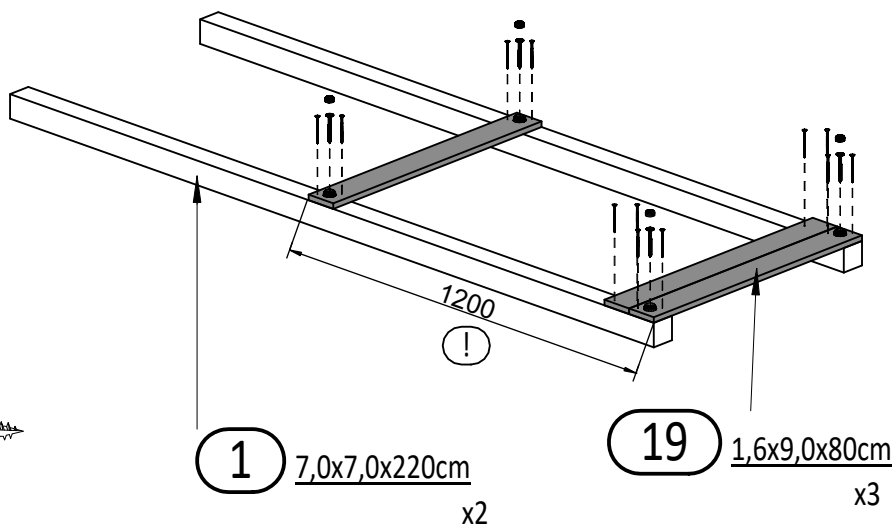
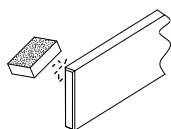
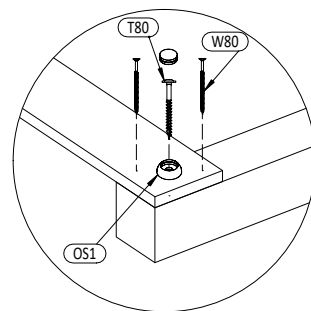
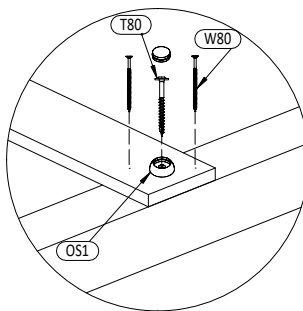
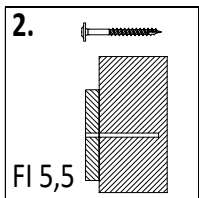
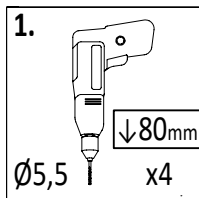

OS1 x4



W80 x12

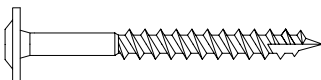

T80 x4

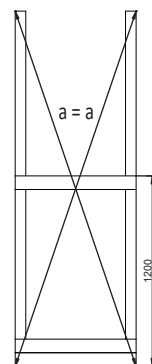

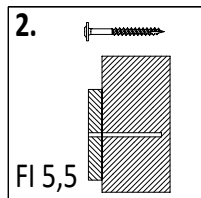
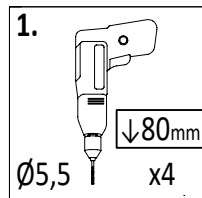
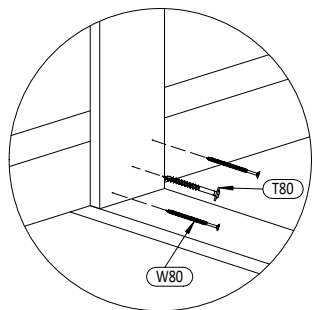

**19** 1,6x9,0x80cm

x6

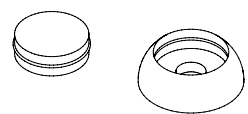
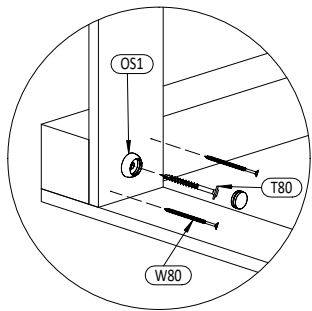
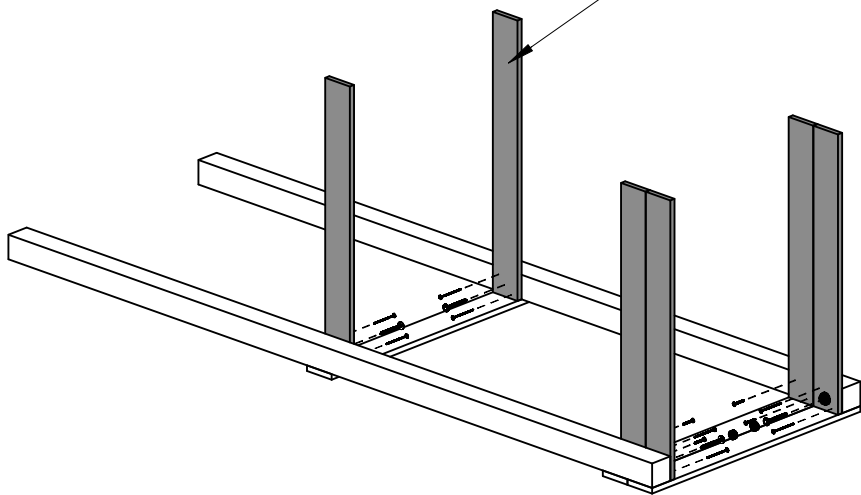

**OS1** x2



**W80** x12



**T80** x4

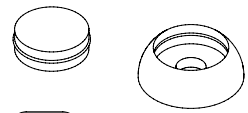
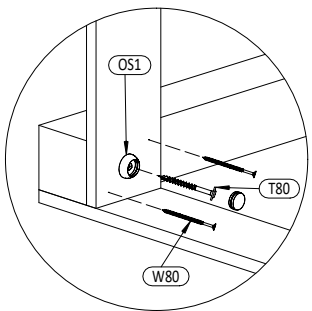
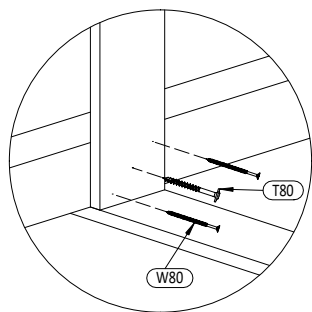
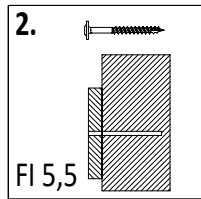
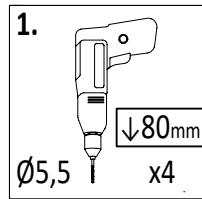
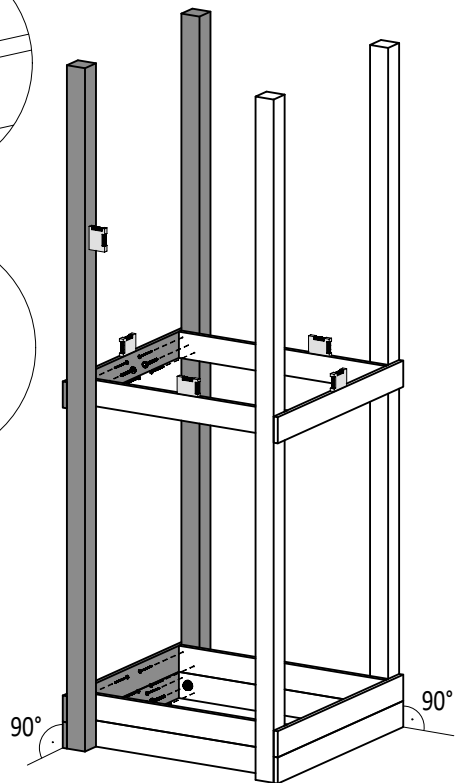
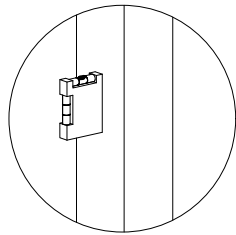
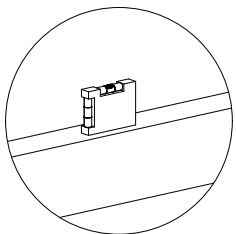

**OS1** x2

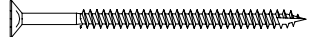

**W80** x12



**T80** x4

05

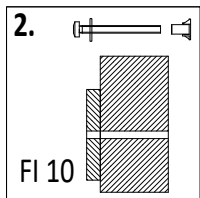
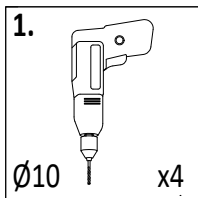

9 3,2x5,8x62,8cm  
x2



OS1 x4

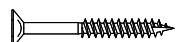

W40 x4

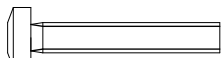

S50 x4



P17 x4



L11 x4

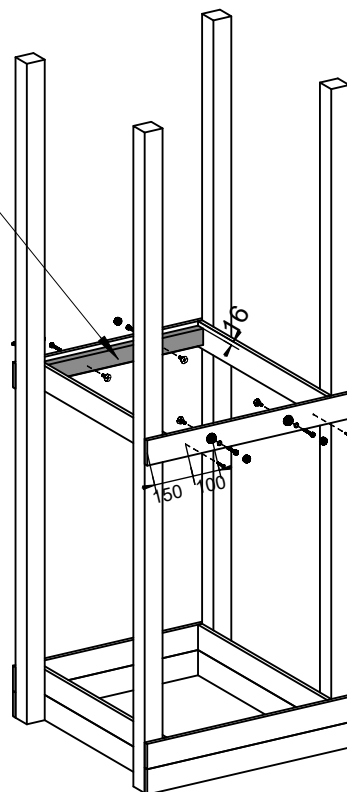
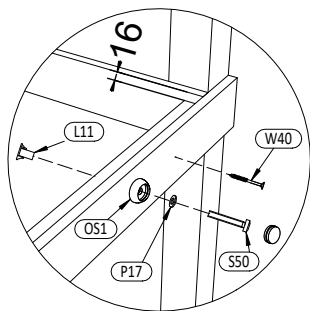

06

9 3,2x5,8x62,8cm  
x1

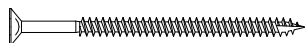
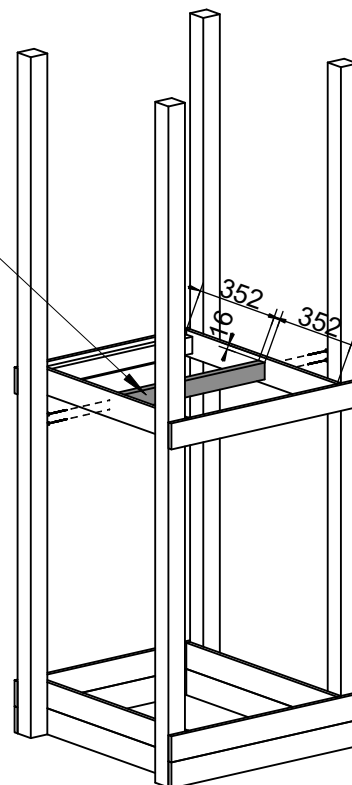
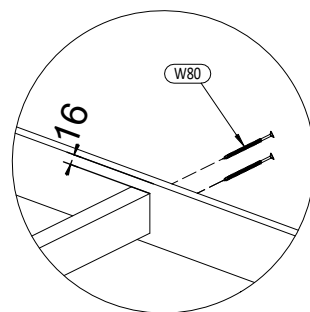

W80 x4

10 FLEPPI V2

Zgodne z normą PN-EN 71 stosuj zalecenia producenta odnośnie odległości oraz metody mocowania poszczególnych elementów  
In compliance with the standard PN-EN 71, apply guidelines of the producer in relation to distances and methods of fastening individual elements

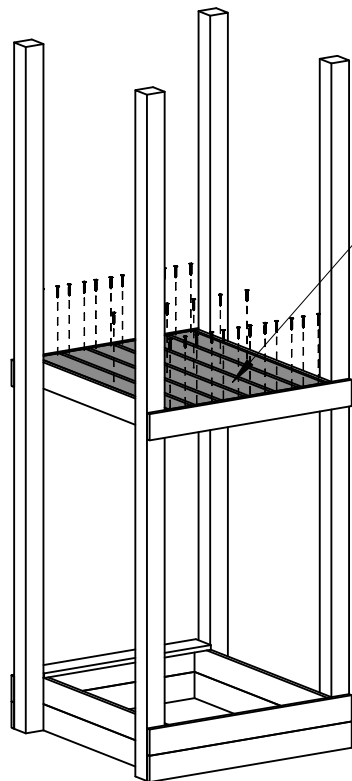
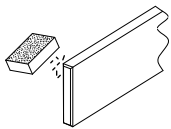

19 1,6x9,0x80cm  
x6

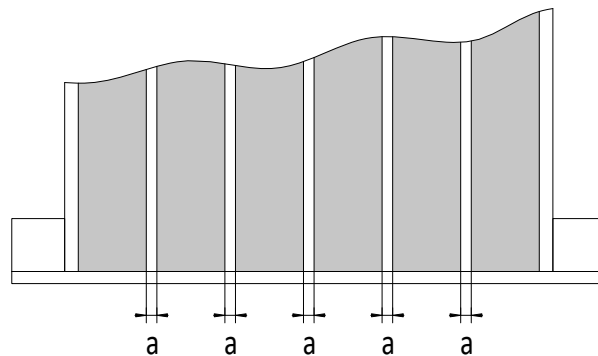

!!!min 13mm < a <!!!max 18mm

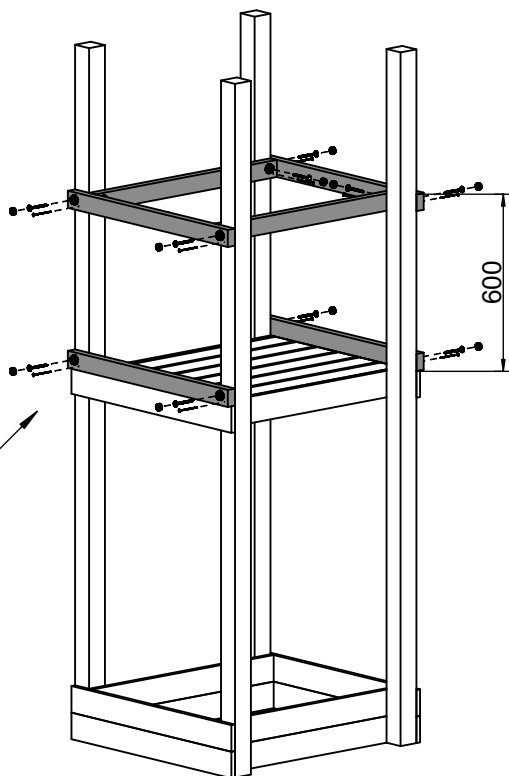
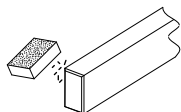
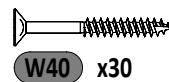
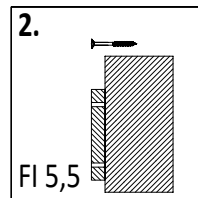
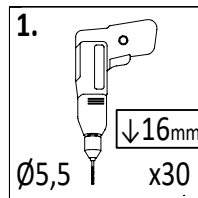

7 3,2x5,8x80cm  
x6

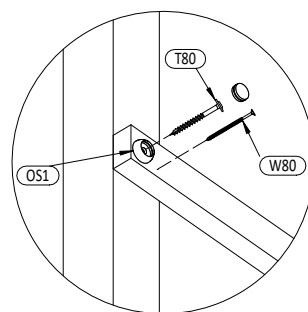
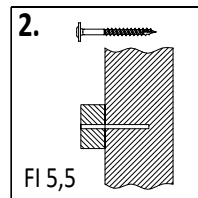
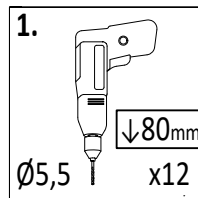

OS1 x12

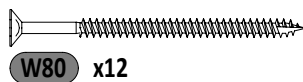

W80 x12

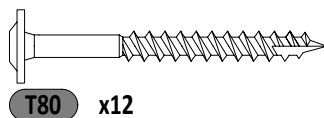

T80 x12

09

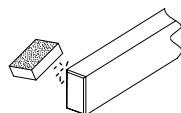
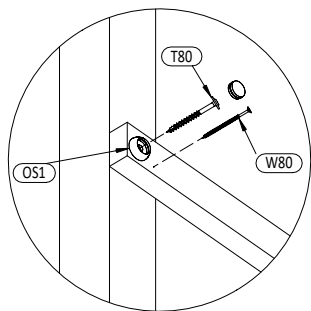
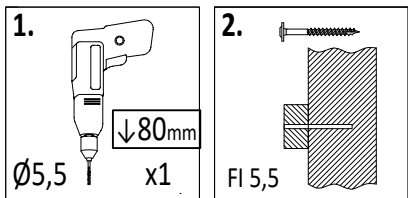

**14** 3,2x5,8x25cm  
x1



OS1 x1

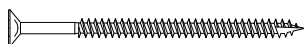

W80 x1

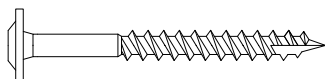

T80 x1

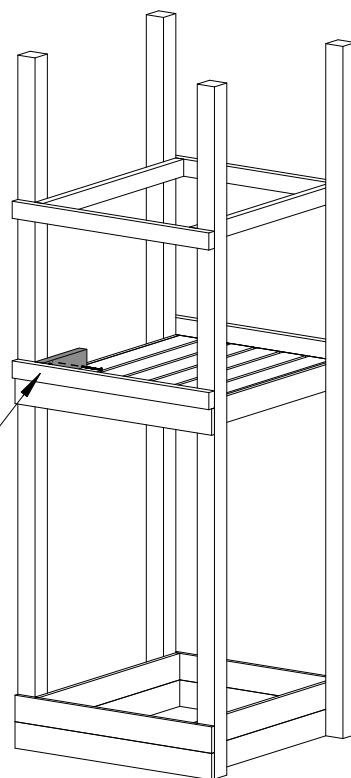

10

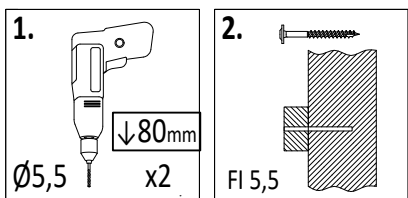

**8** 3,2x5,8x69cm  
x1

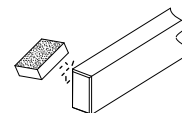
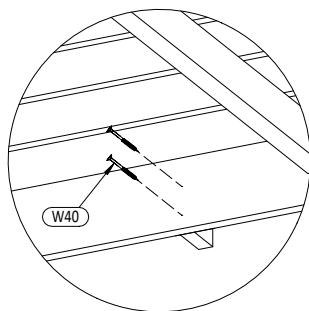
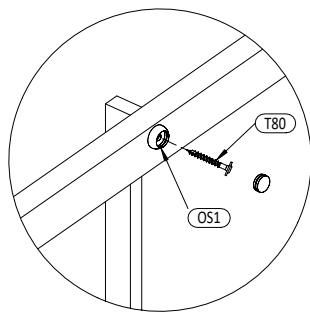

OS1 x2

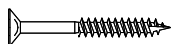

W40 x2

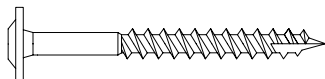

T80 x2

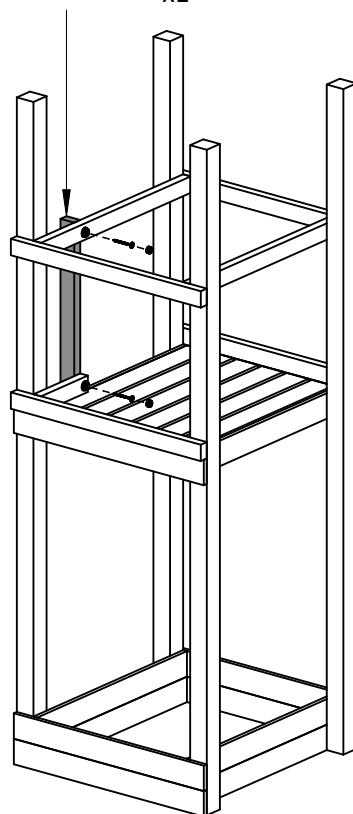

28a 2,7x3,2x54,2cm

x3

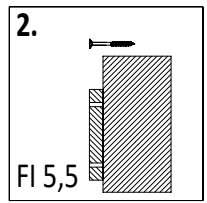
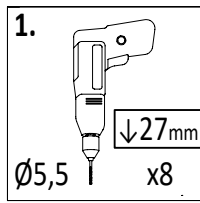
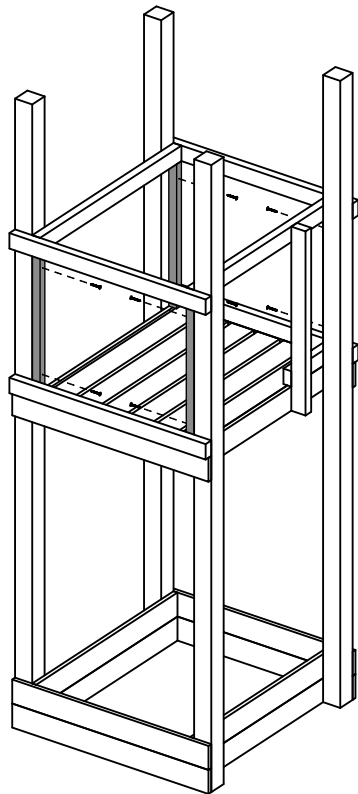

29a 2,7x3,2x48,4cm x1

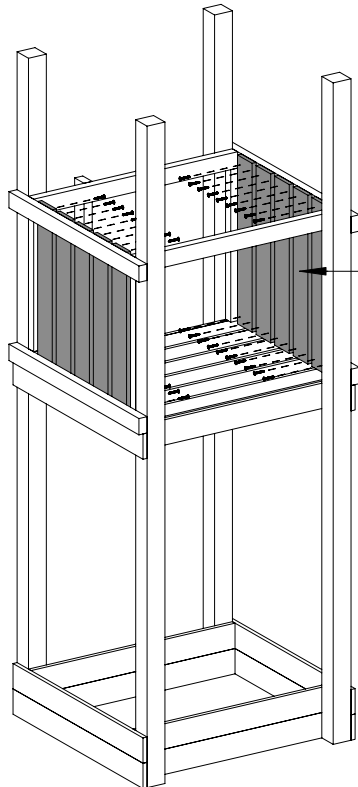
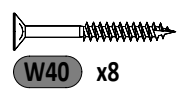
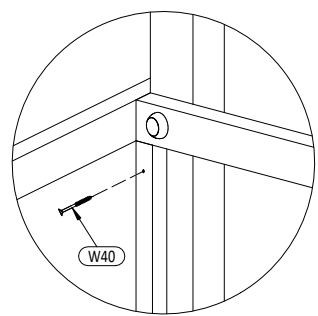

23 1,6x9,0x60cm x10

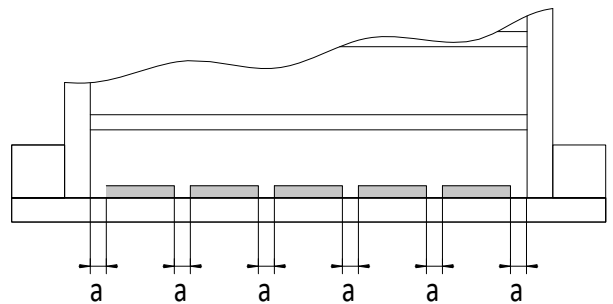
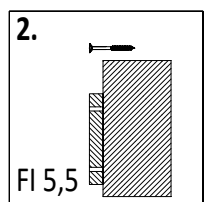
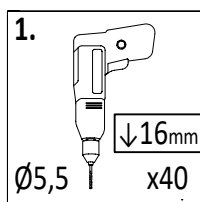
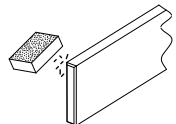

!!!min 13mm < a < !!!max 23mm

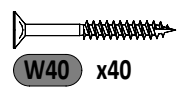

Zgodnie z normą PN-EN 71 stosuj zalecenia producenta odnośnie odległości oraz metody mocowania poszczególnych elementów  
In compliance with the standard PN-EN 71, apply guidelines of the producer in relation to distances and methods of fastening individual elements

13

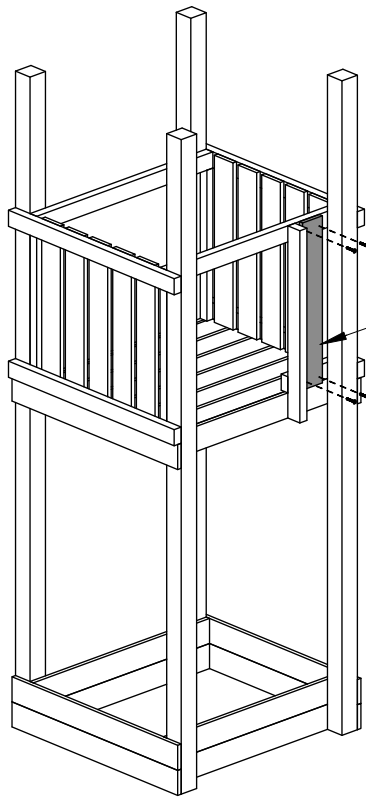
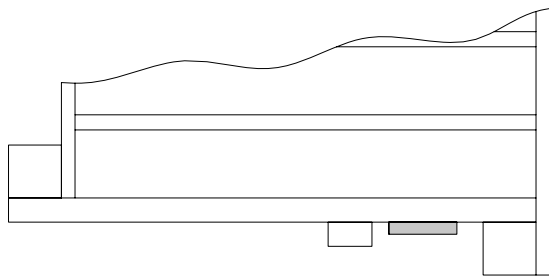
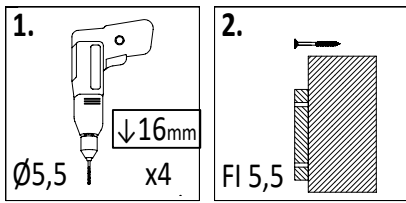

**23** 1,6x9,0x60cm  
x1

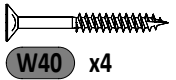
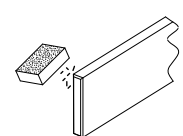

14

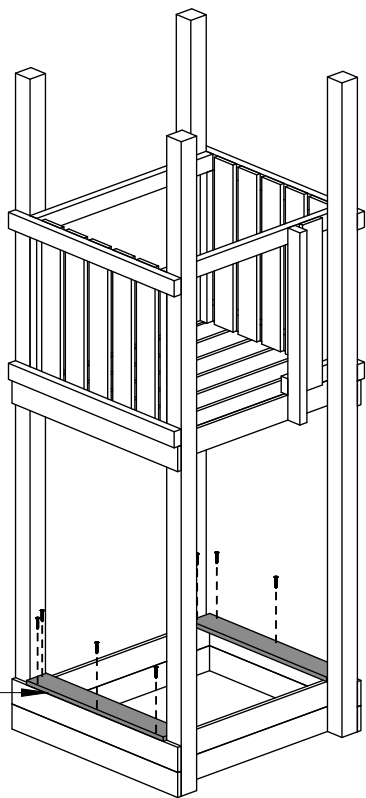
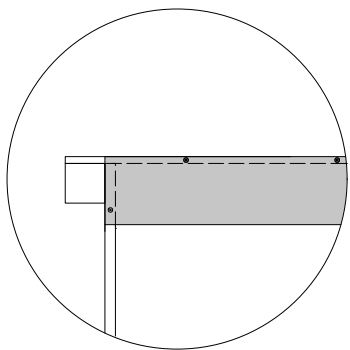
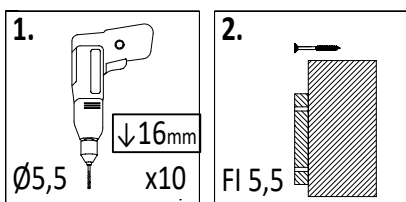

**21** 1,6x9,0x66cm  
x2

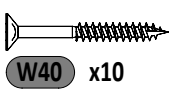
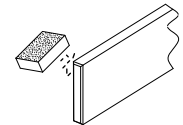

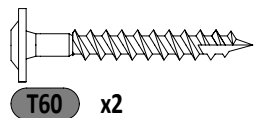
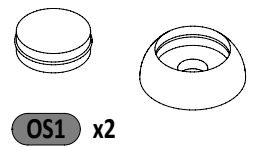
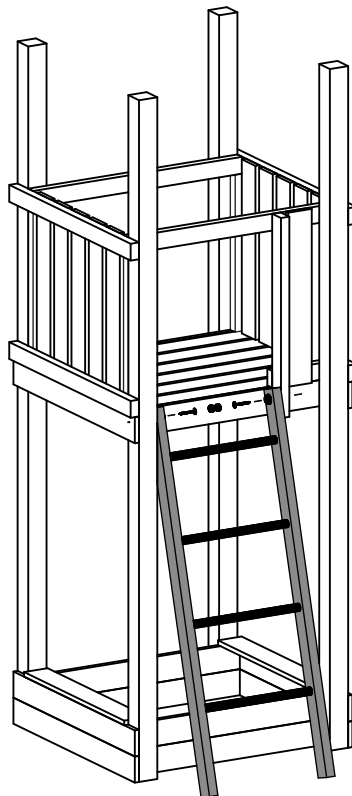
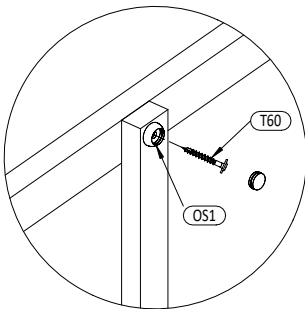
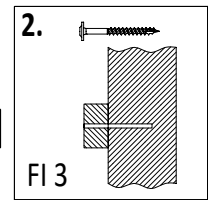
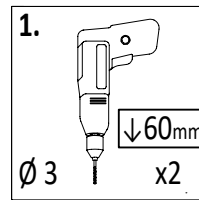
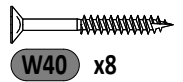
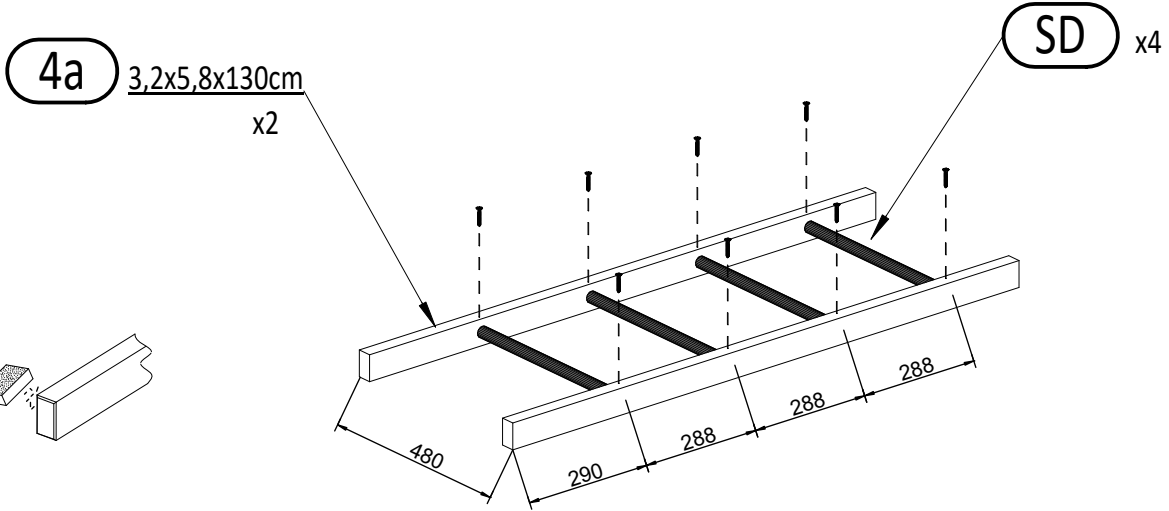
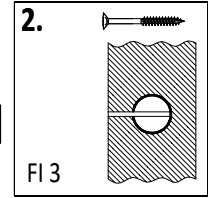
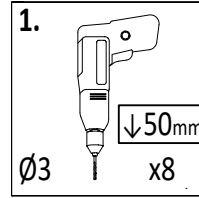
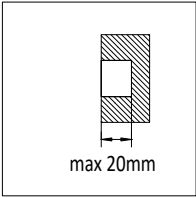

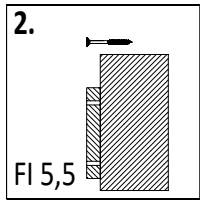
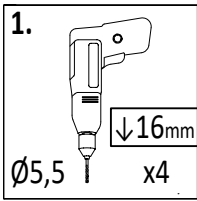

x2

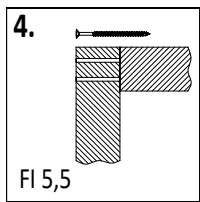
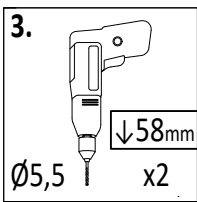

25a  $1,6 \times 9,0 \times 56\text{cm}$   
x1

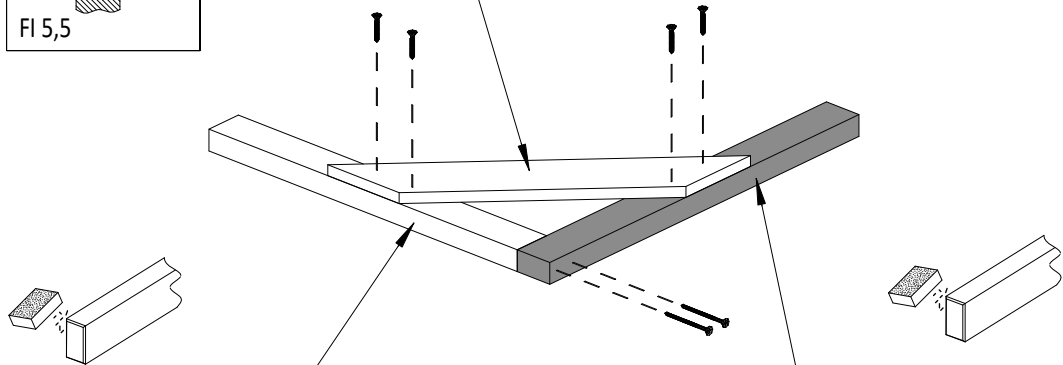

11  $3,2 \times 5,8 \times 55\text{cm}$   
x1

10  $3,2 \times 5,8 \times 61\text{cm}$   
x1

W40 x4\*2=8

W80 x2\*2=4

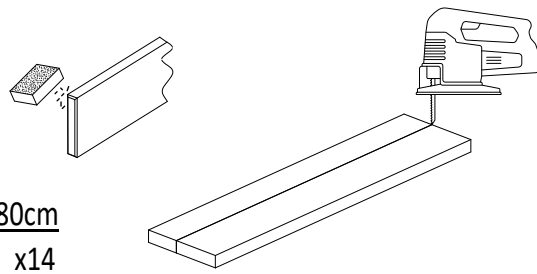
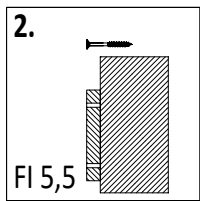
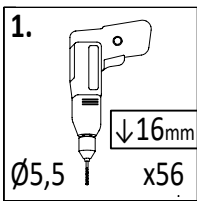

19  $1,6 \times 9,0 \times 80\text{cm}$   
x14

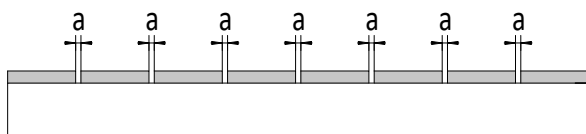
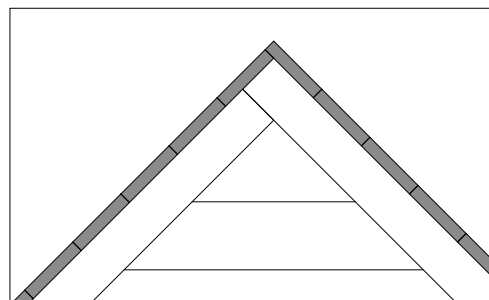
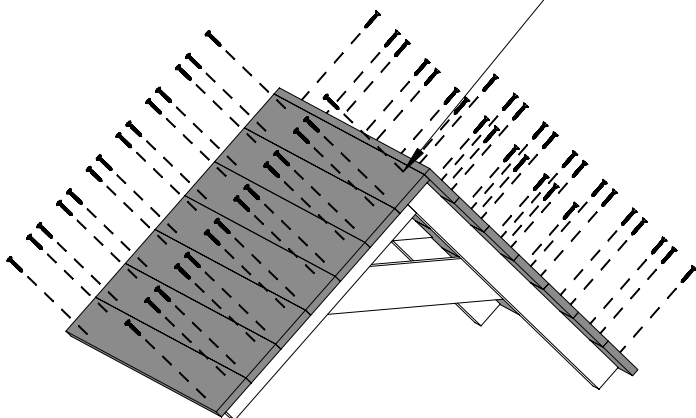

W40 x56

!!!min 2mm < a < !!!max 6mm

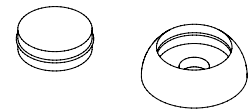
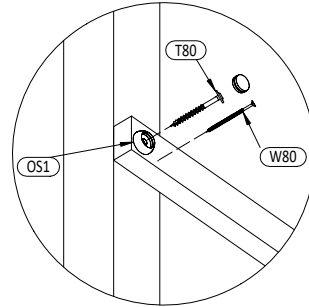
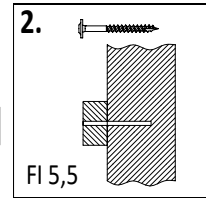
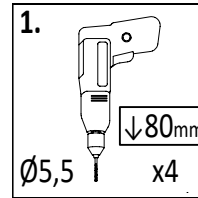
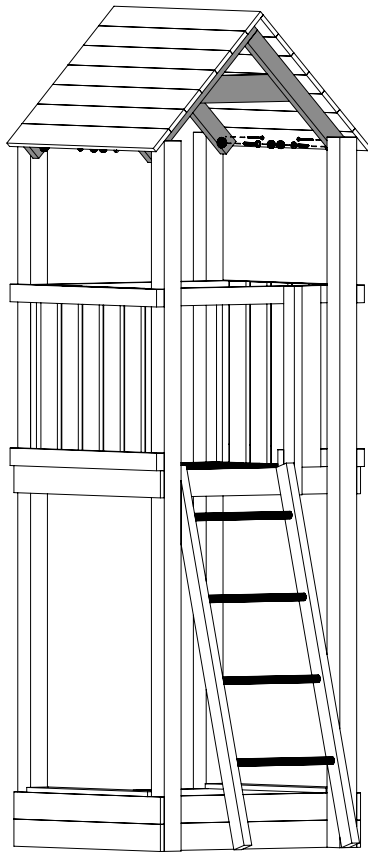

OS1 x4

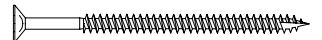

W80 x4



T80 x4

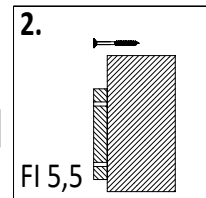
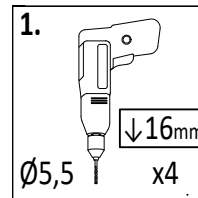

19 1,6x9,0x80cm  
x1

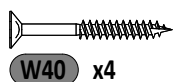
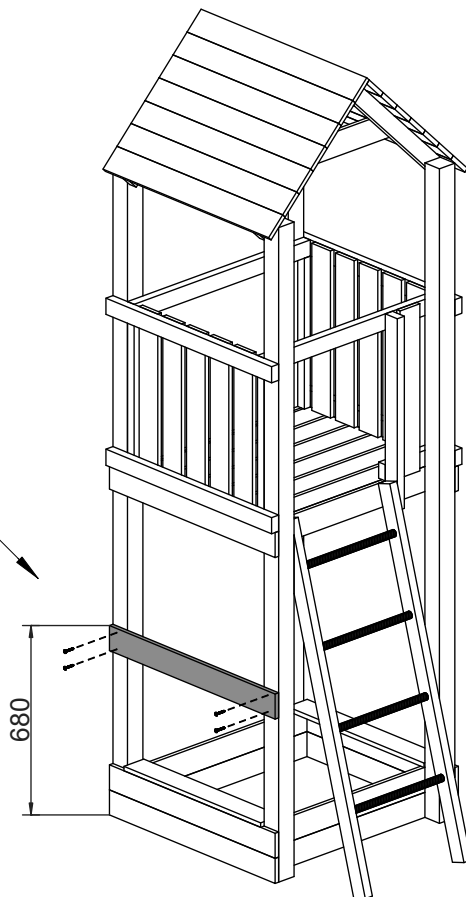
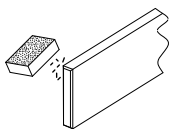

W40 x4

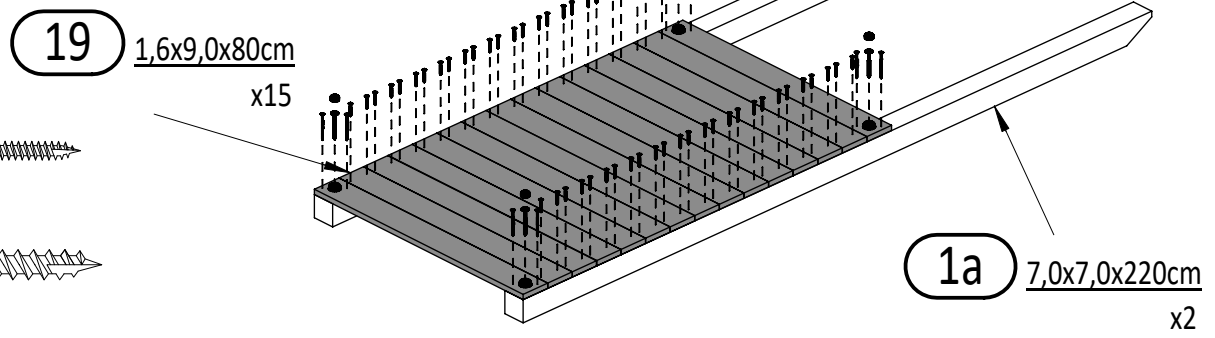
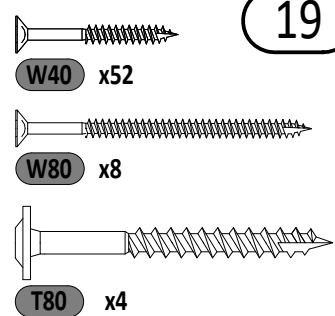
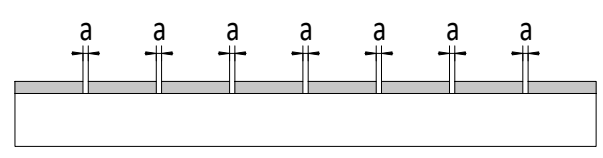
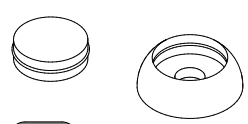
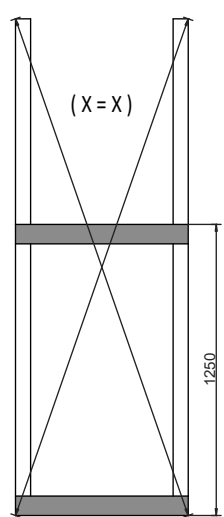
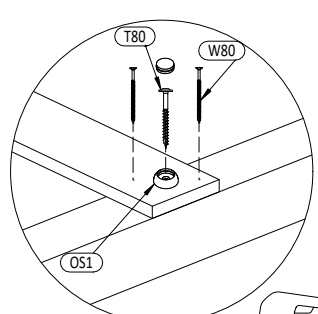
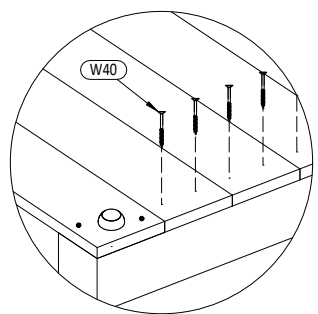
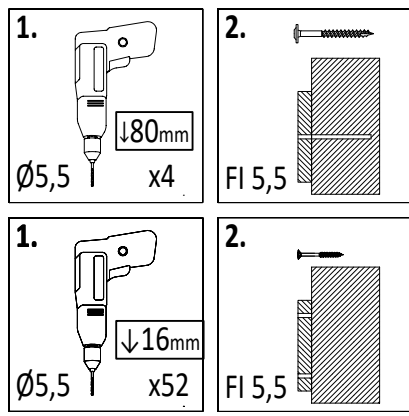
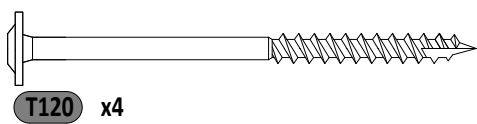
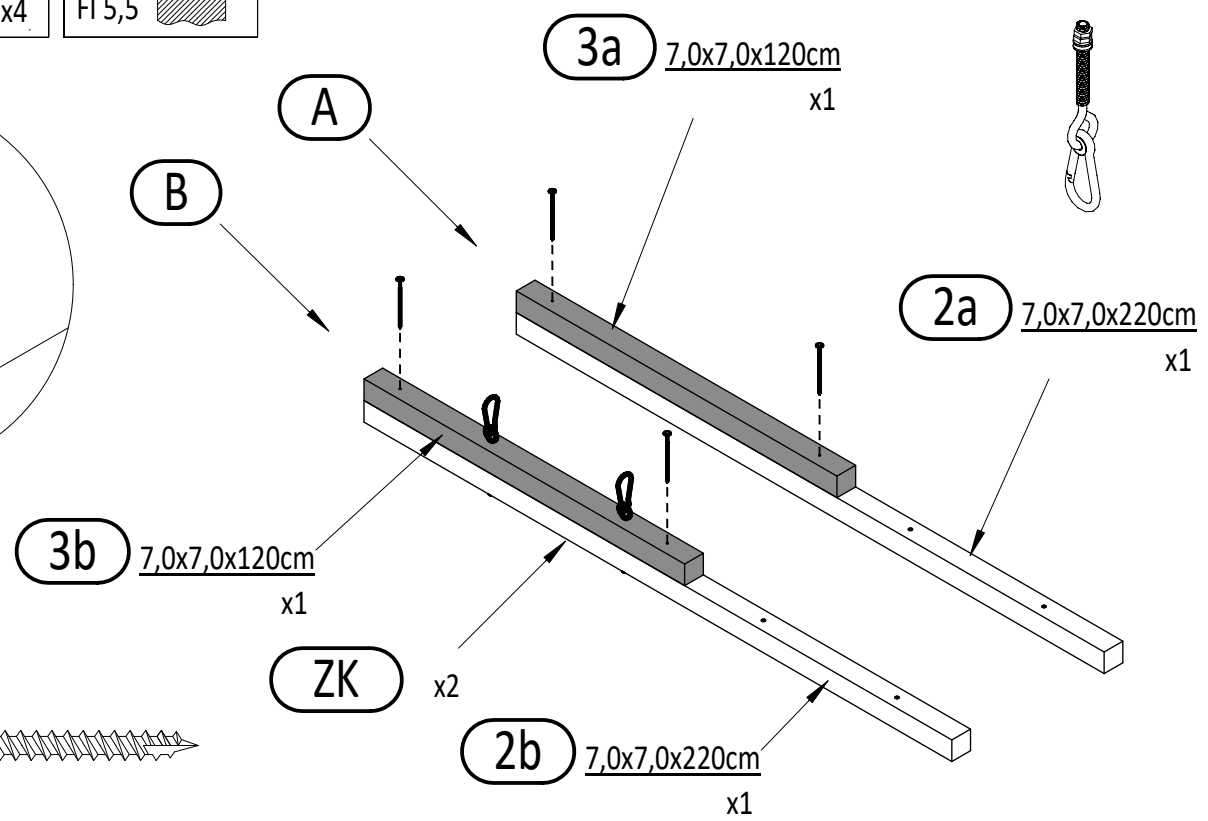
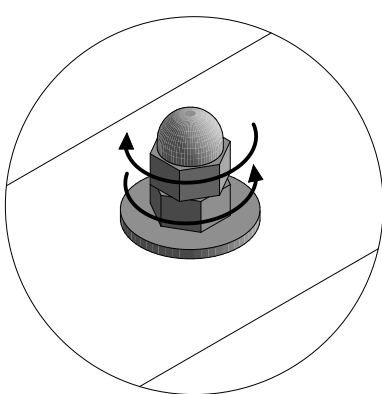
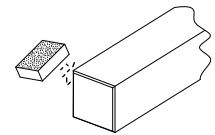
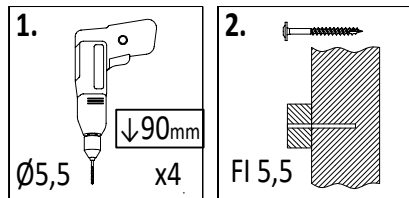

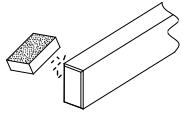
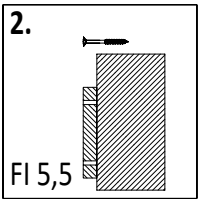
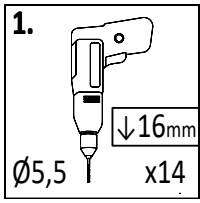

5 3,2x5,8x120cm  
x1

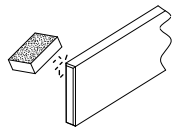
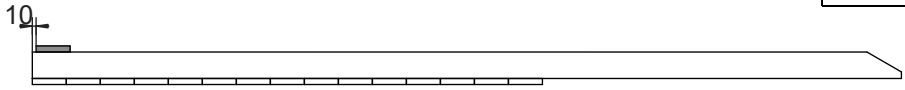
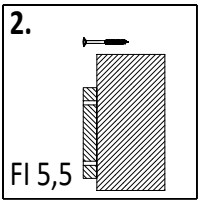
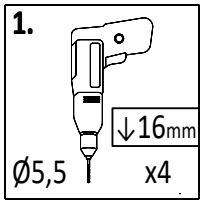
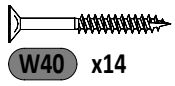
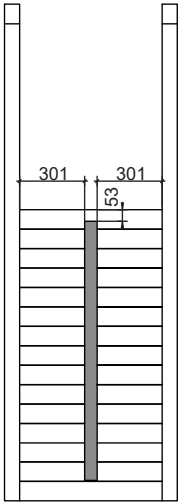
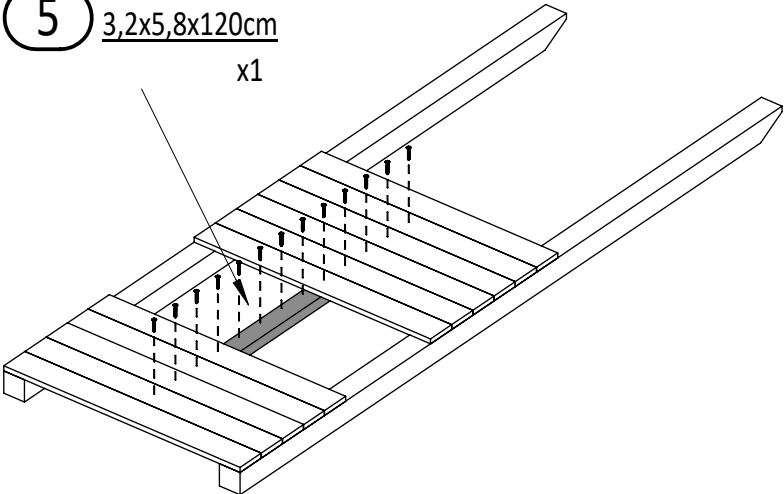

19 1,6x9,0x80cm  
x1

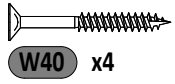
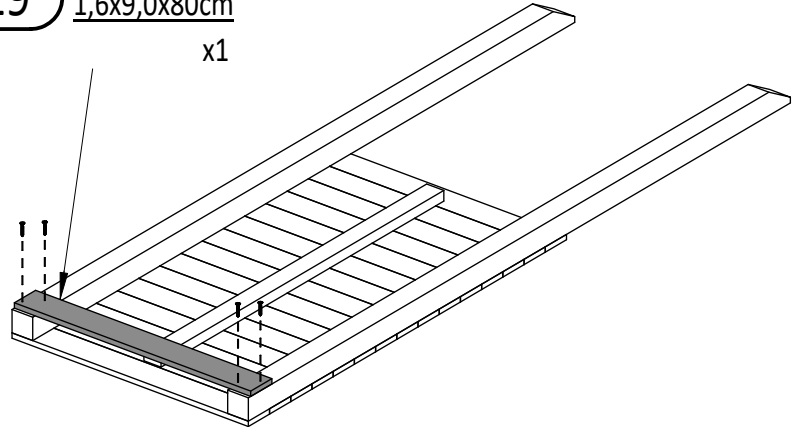

Zgodne z normą PN-EN 71 stosuj zalecenia producenta odnośnie odległości oraz metody mocowania poszczególnych elementów  
 In compliance with the standard PN-EN 71, apply guidelines of the producer in relation to distances and methods of fastening individual elements

25

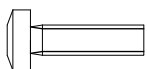
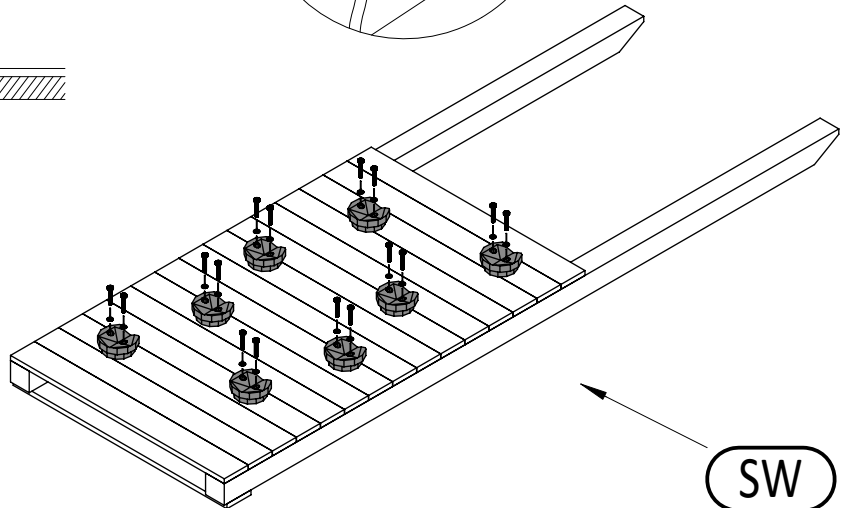
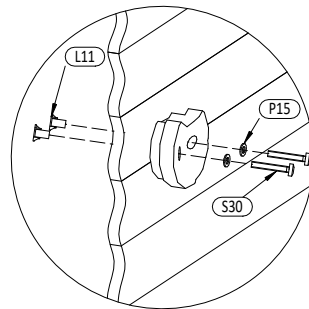
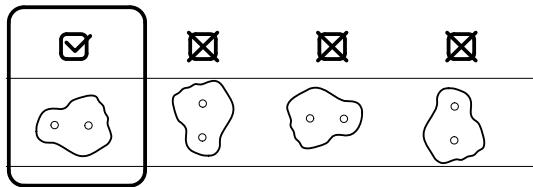
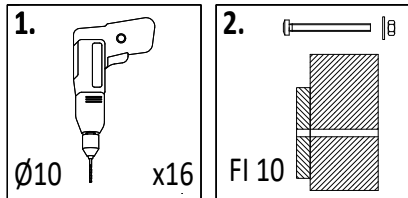

S30 x16



P15 x16



L11 x16

26

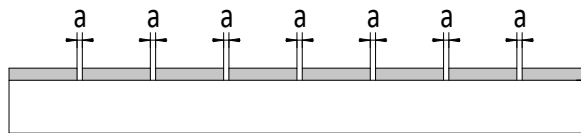
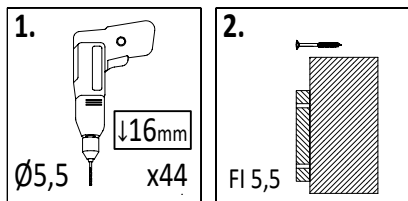
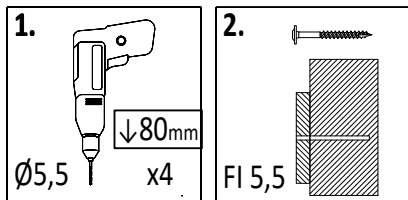

!!!min 2mm < a < !!!max 6mm

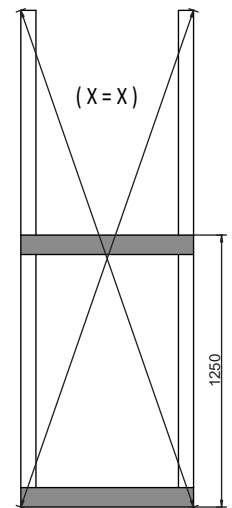

1a 7,0x7,0x220cm x2

19 1,6x9,0x80cm x12

19a 1,6x9,0x80cm x1

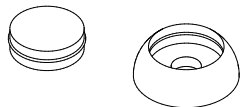

OS1 x4

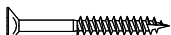

W40 x44



W80 x14

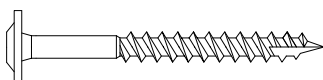

T80 x4

7 3,2x5,8x80cm x3

20 FLEPPI V2

Zgodne z normą PN-EN 71 stosuj zalecenia producenta odnośnie odległości oraz metody mocowania poszczególnych elementów  
In compliance with the standard PN-EN 71, apply guidelines of the producer in relation to distances and methods of fastening individual elements

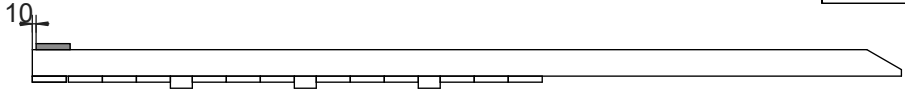
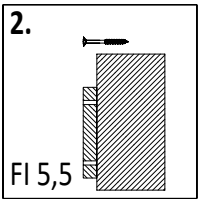
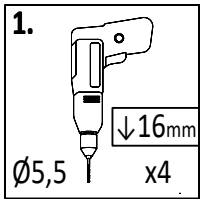

19 1,6x9,0x80cm  
x1

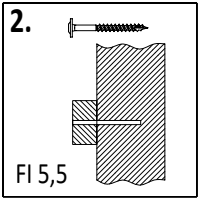
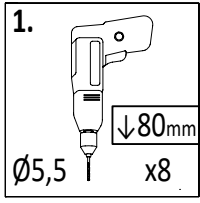
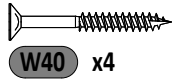
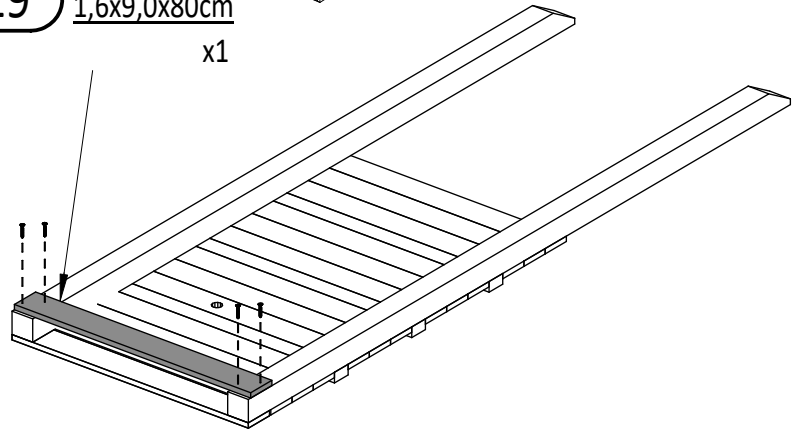

13a 3,2x5,8x30,0cm  
x2

12a 3,2x5,8x36,7cm  
x2

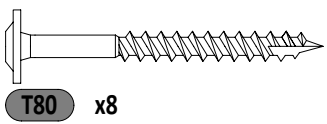
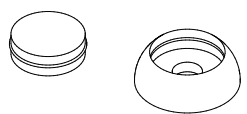
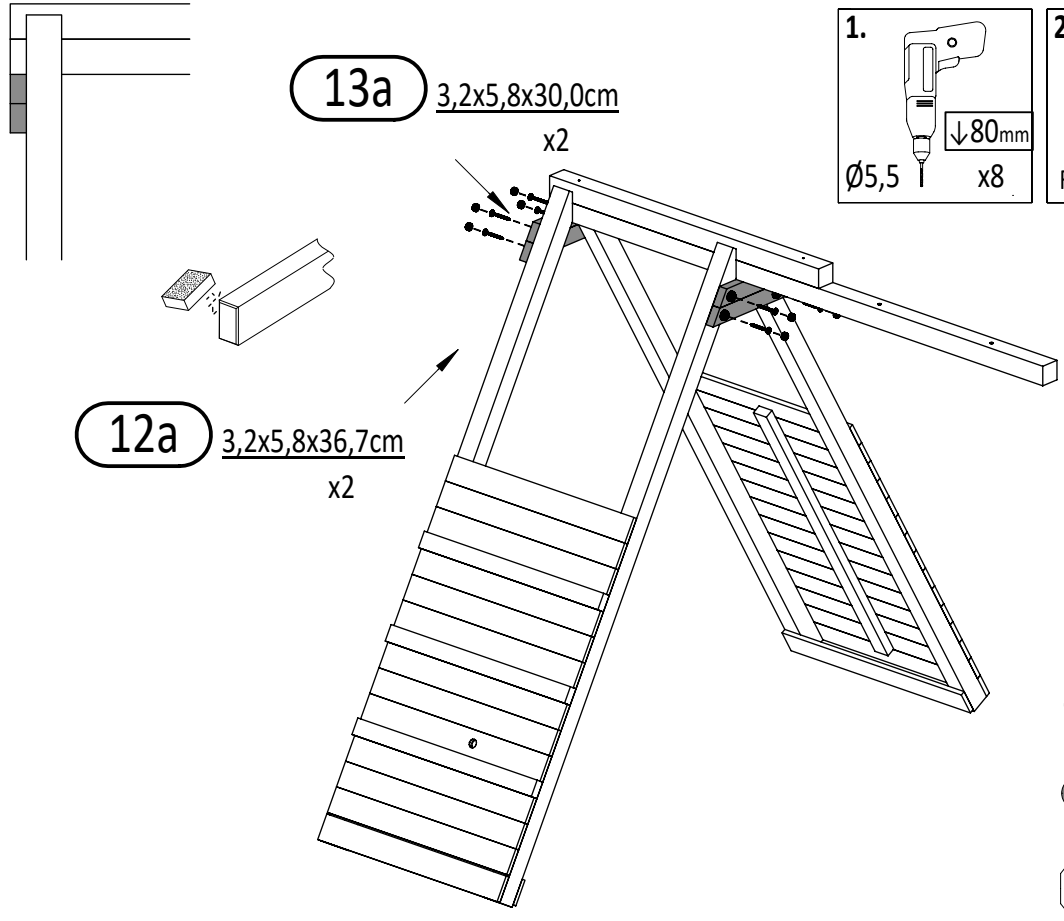

Zgodnie z normą PN-EN 71 stosuj zalecenia producenta odnośnie odległości oraz metody mocowania poszczególnych elementów  
In compliance with the standard PN-EN 71, apply guidelines of the producer in relation to distances and methods of fastening individual elements

29

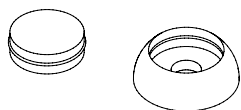
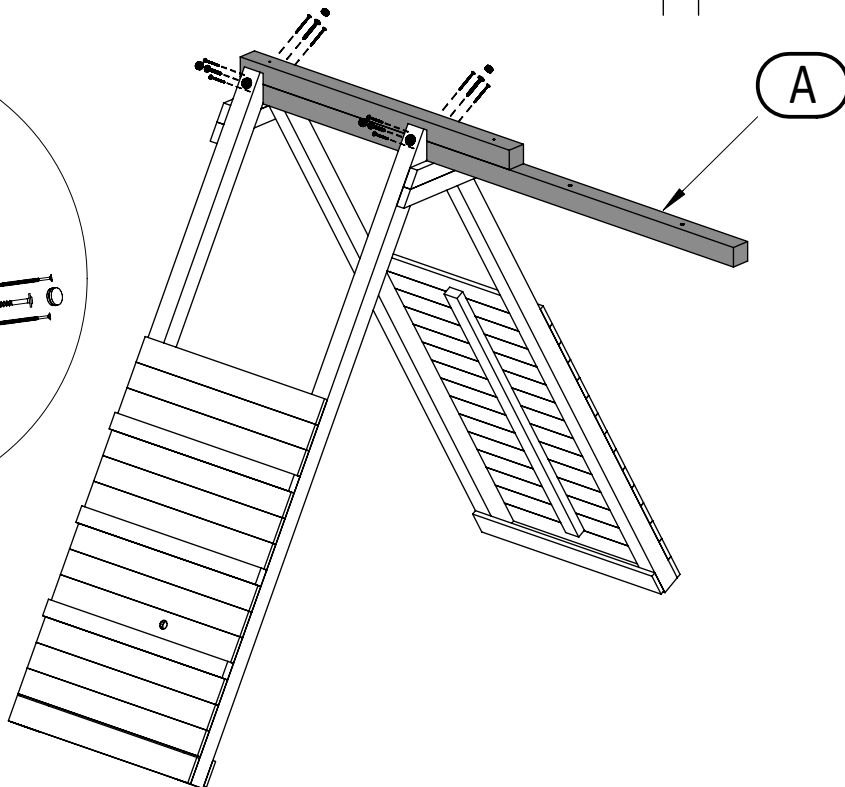
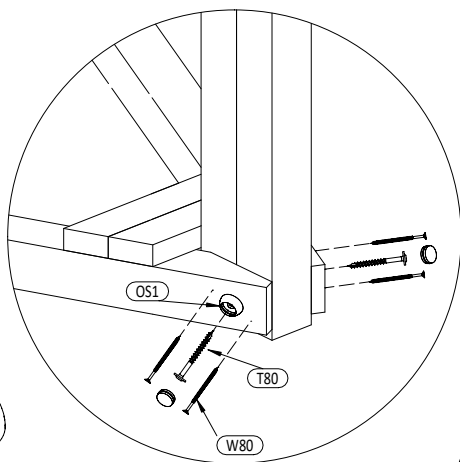
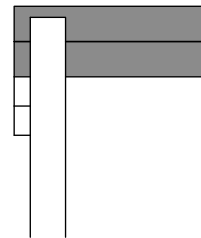
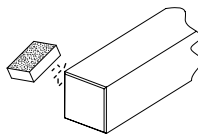
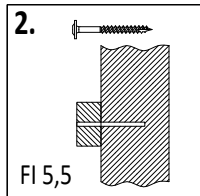
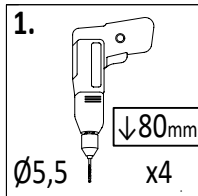

OS1 x4

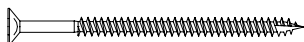

W80 x8

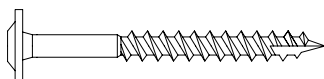

T80 x4

30

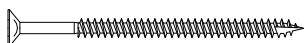
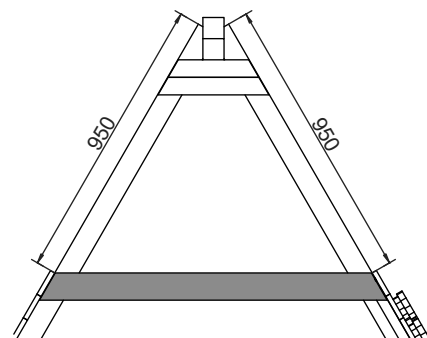
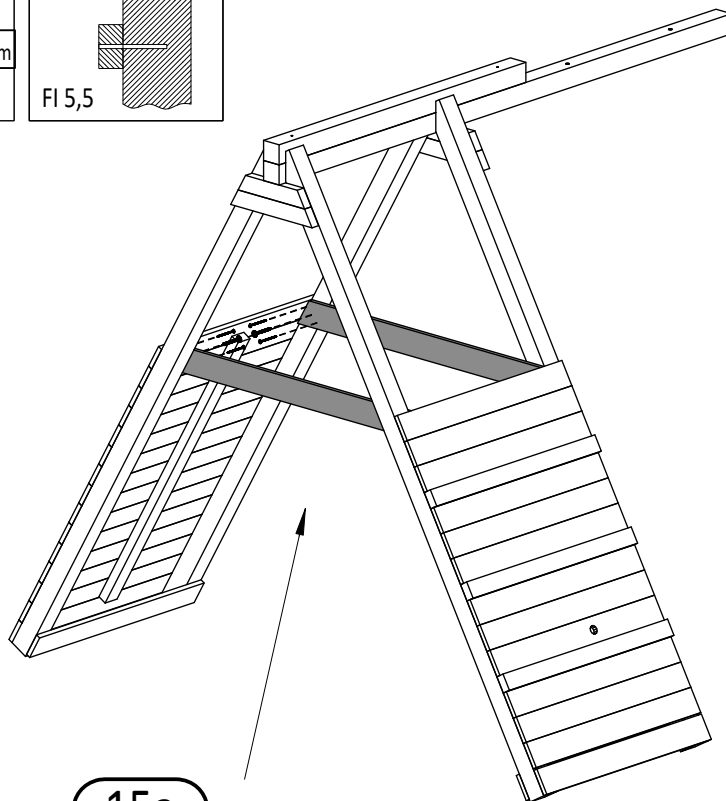
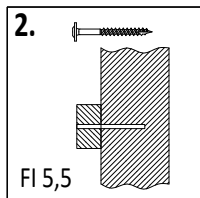
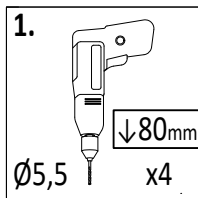

W80 x8

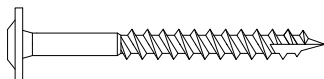

T80 x4

**15a** 1,6x9,0x115,0cm  
x2

**6** 3,2x5,8x106,5cm  
x3

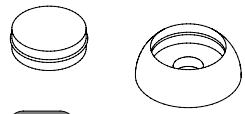
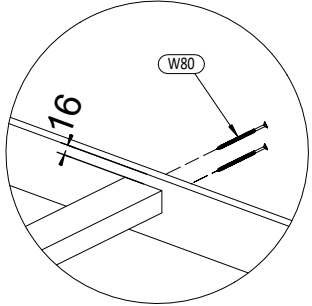
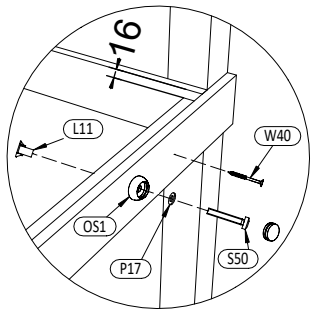
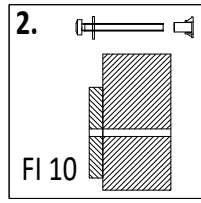
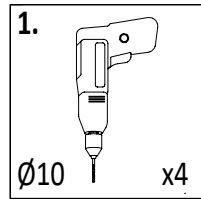
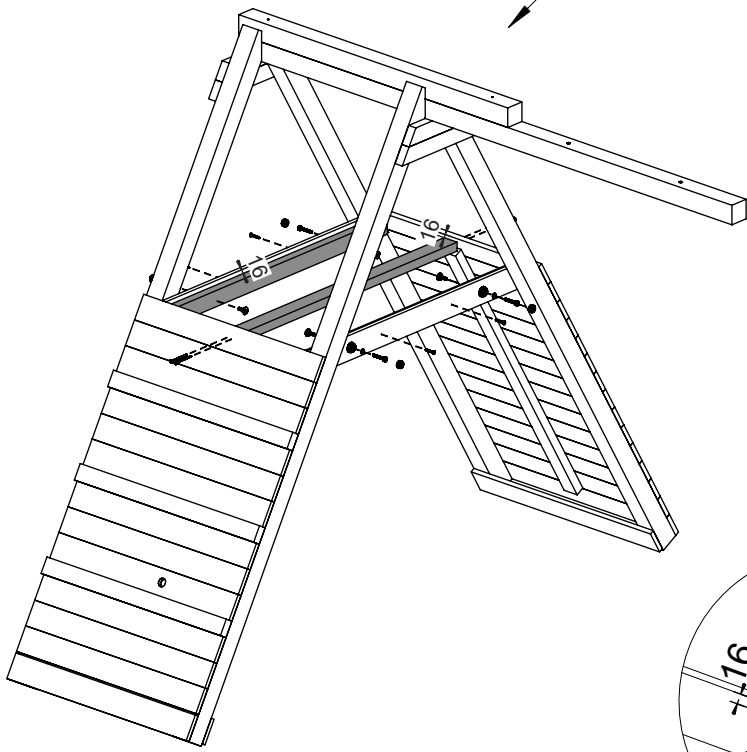

OS1 x4

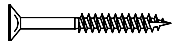

W40 x4

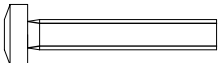

S50 x4



P17 x4



L11 x4

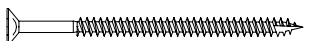

W80 x4

**22** 1,6x9,0x62,8cm  
x10

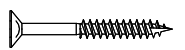
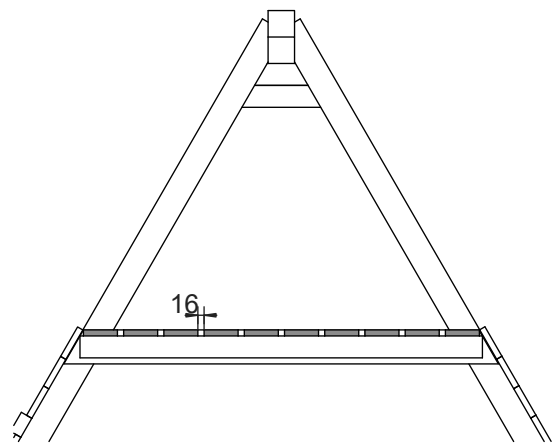
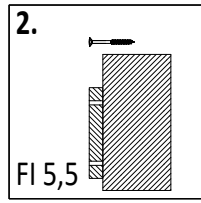
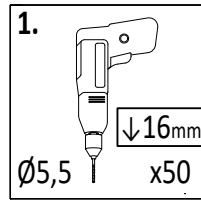
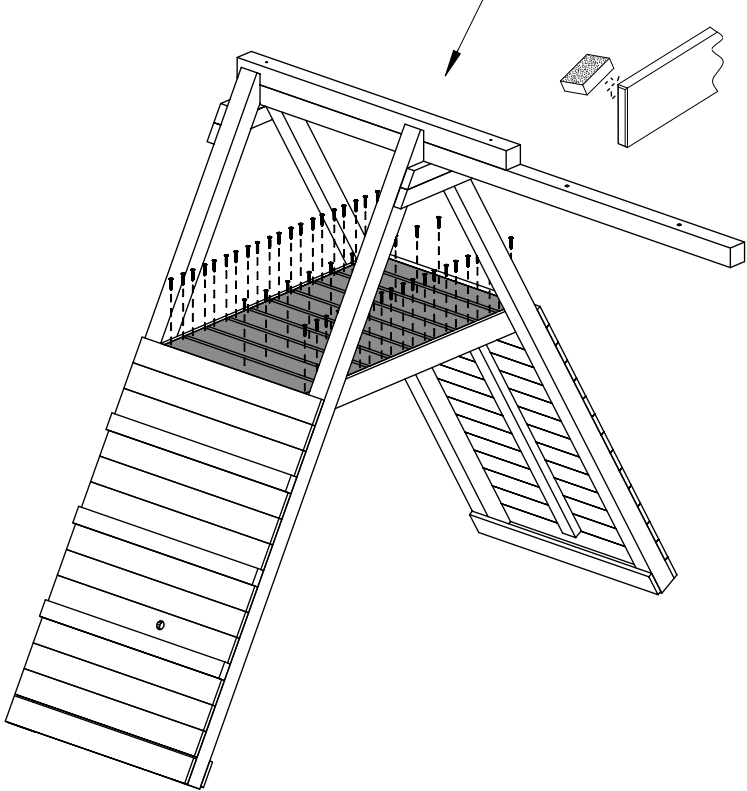

W40 x50

Zgodnie z normą PN-EN 71 stosuj zalecenia producenta odnośnie odległości oraz metody mocowania poszczególnych elementów  
In compliance with the standard PN-EN 71, apply guidelines of the producer in relation to distances and methods of fastening individual elements

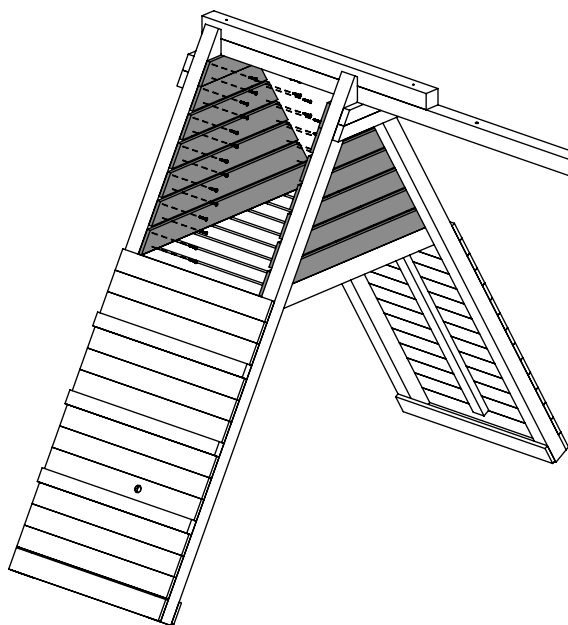
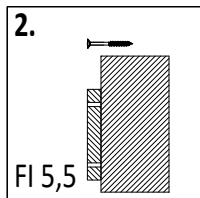
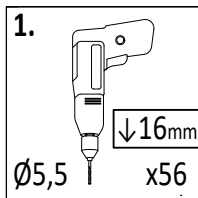

27a  $1,6 \times 9,0 \times 34,0\text{cm}$   
x2

26a  $1,6 \times 9,0 \times 44,0\text{cm}$   
x2

24a  $1,6 \times 9,0 \times 56,5\text{cm}$   
x2

20a  $1,6 \times 9,0 \times 68,5\text{cm}$   
x2

18a  $1,6 \times 9,0 \times 80,5\text{cm}$   
x2

17a  $1,6 \times 9,0 \times 92,5\text{cm}$   
x2

16a  $1,6 \times 9,0 \times 105,0\text{cm}$   
x2

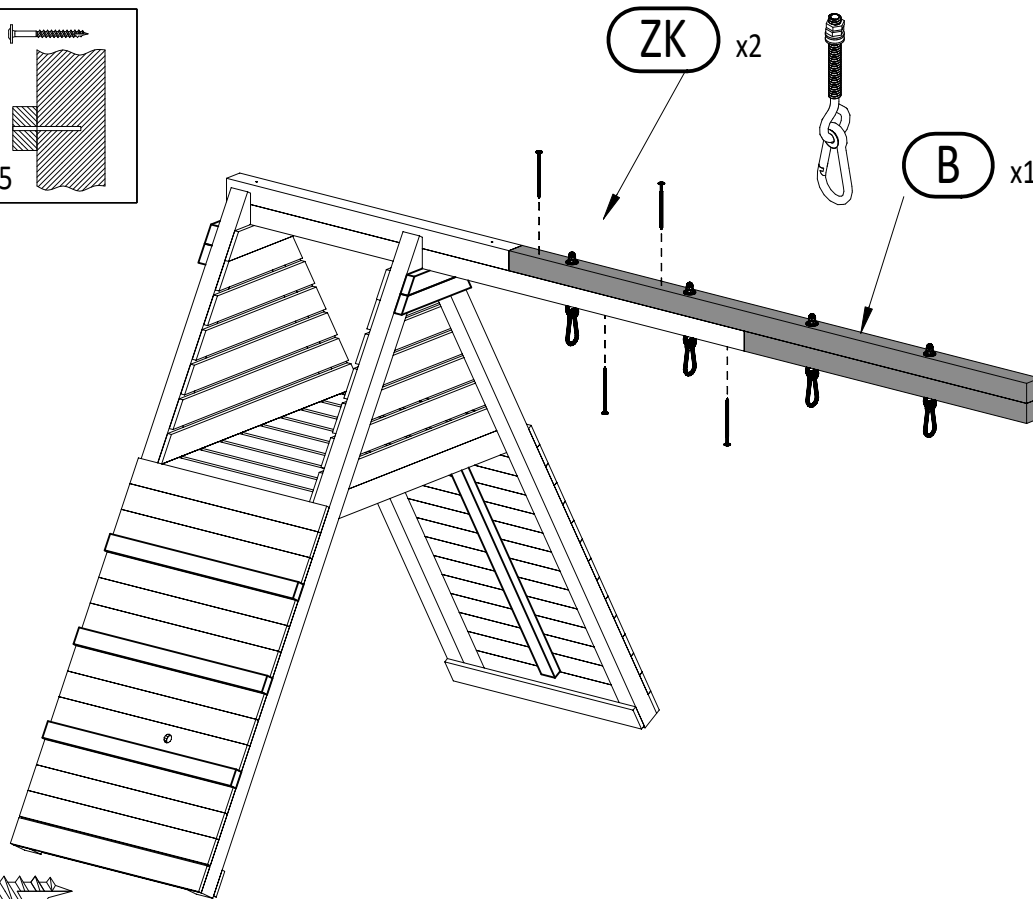
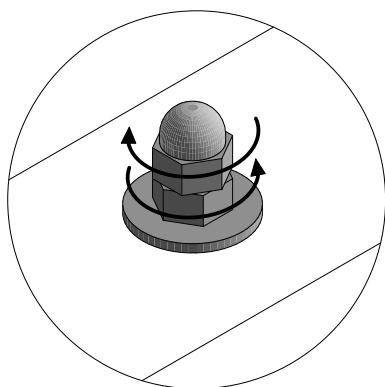
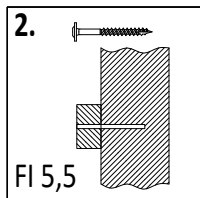
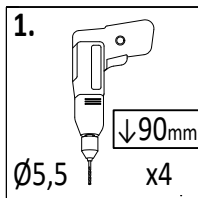
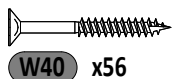
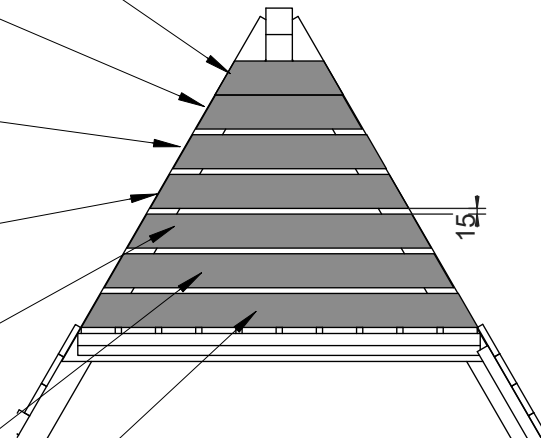
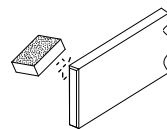

ZK x2

B x1

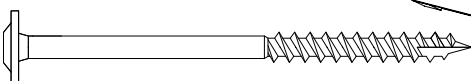

T120 x4

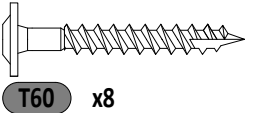
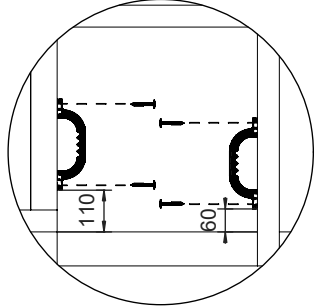
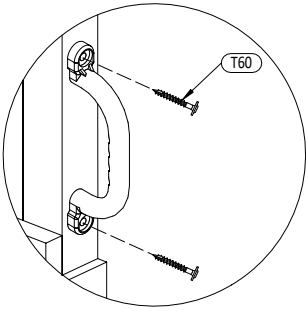
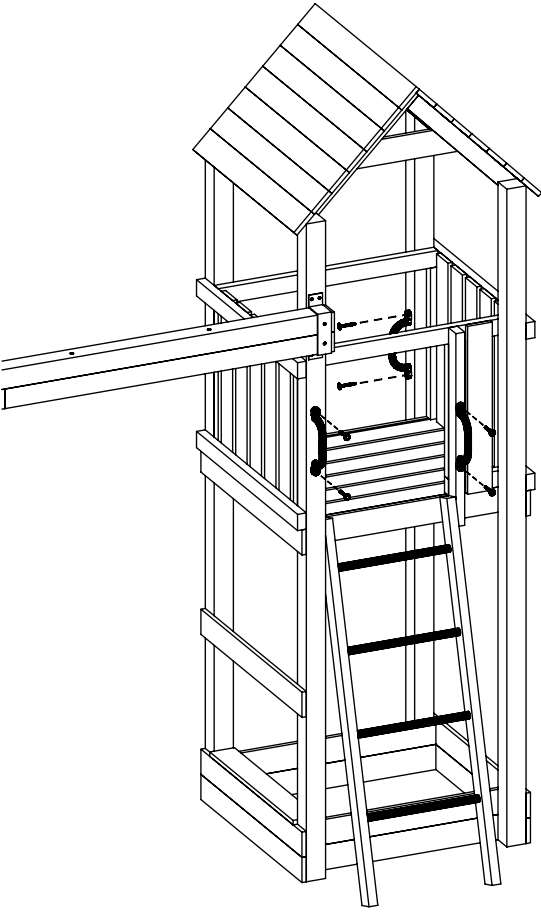
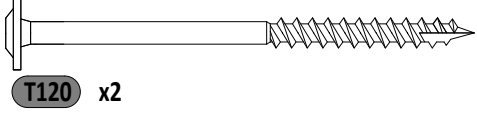
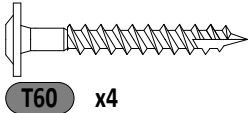
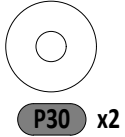
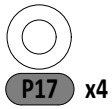
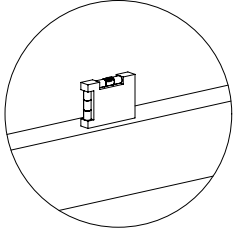
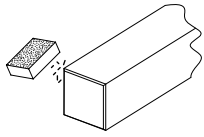
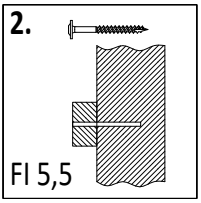
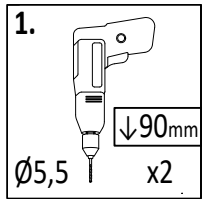
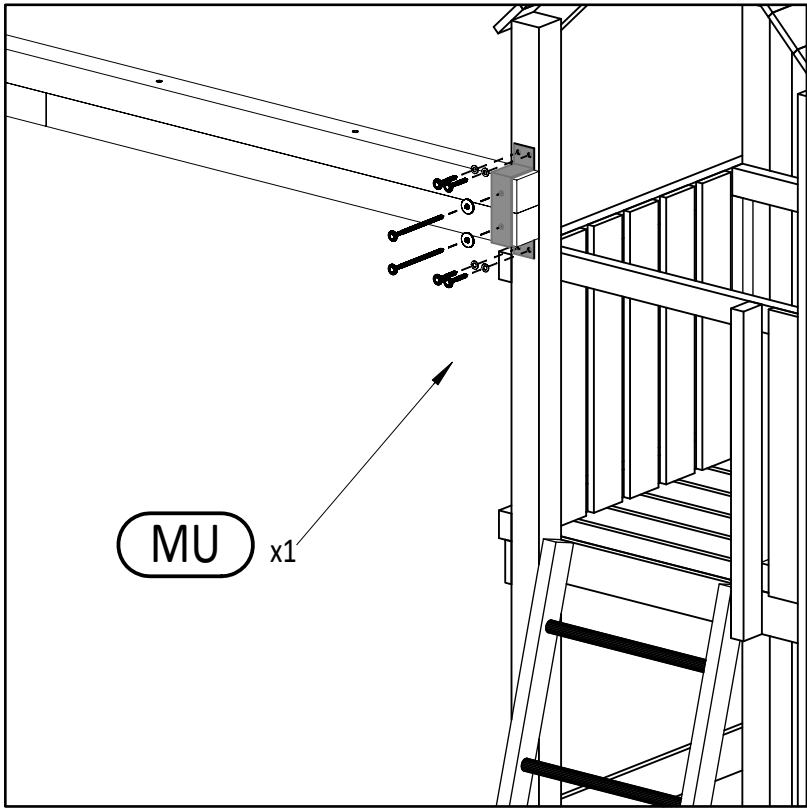

Zgodnie z normą PN-EN 71 stosuj zalecenia producenta odnośnie odległości oraz metody mocowania poszczególnych elementów  
 In compliance with the standard PN-EN 71, apply guidelines of the producer in relation to distances and methods of fastening individual elements

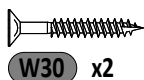
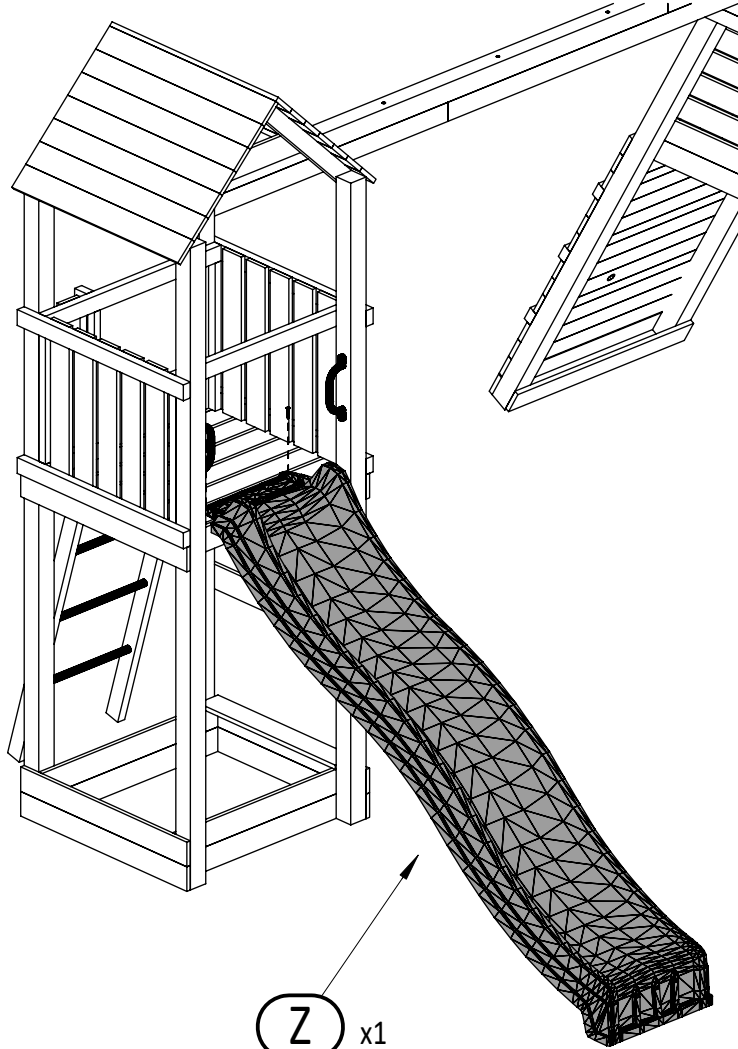
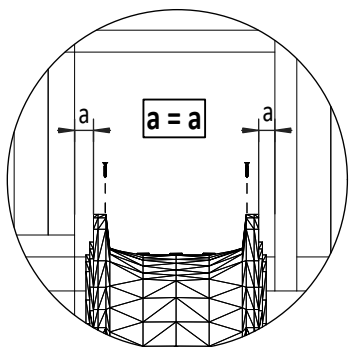

W30 x2

Z x1

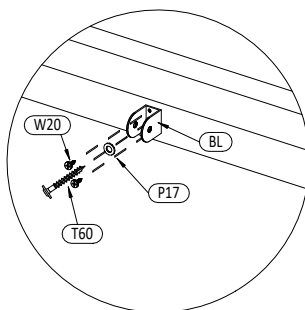
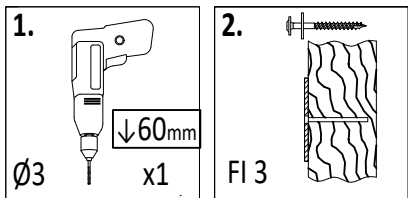

BL x1

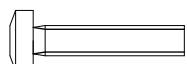

S40 x1



P17 x2



NS x1



W20 x2

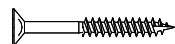

W40 x2

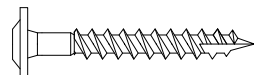

T60 x1

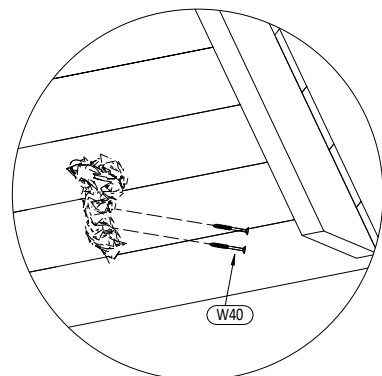
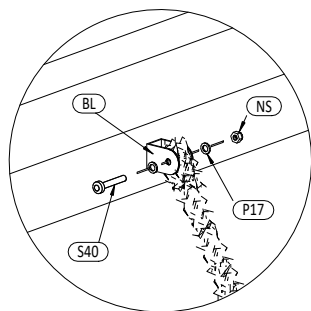

LI x1

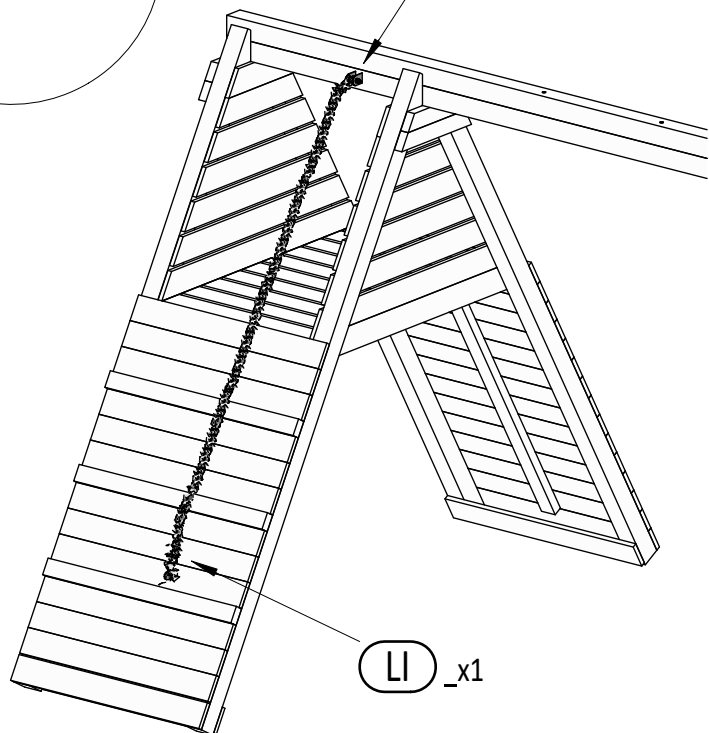

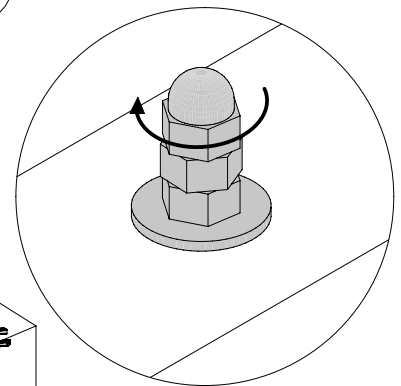
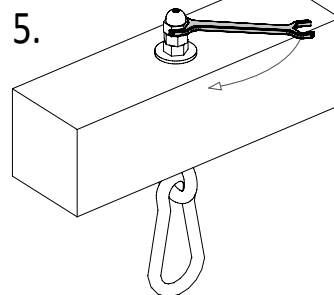
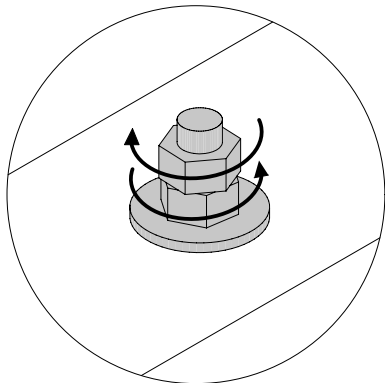
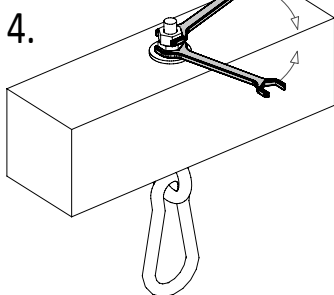
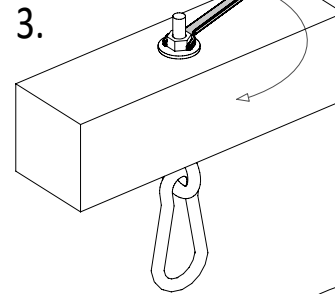
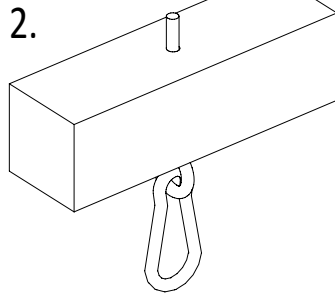
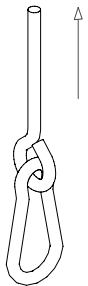
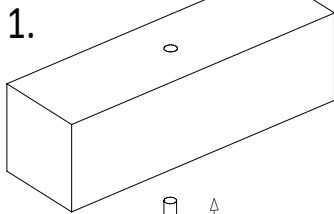
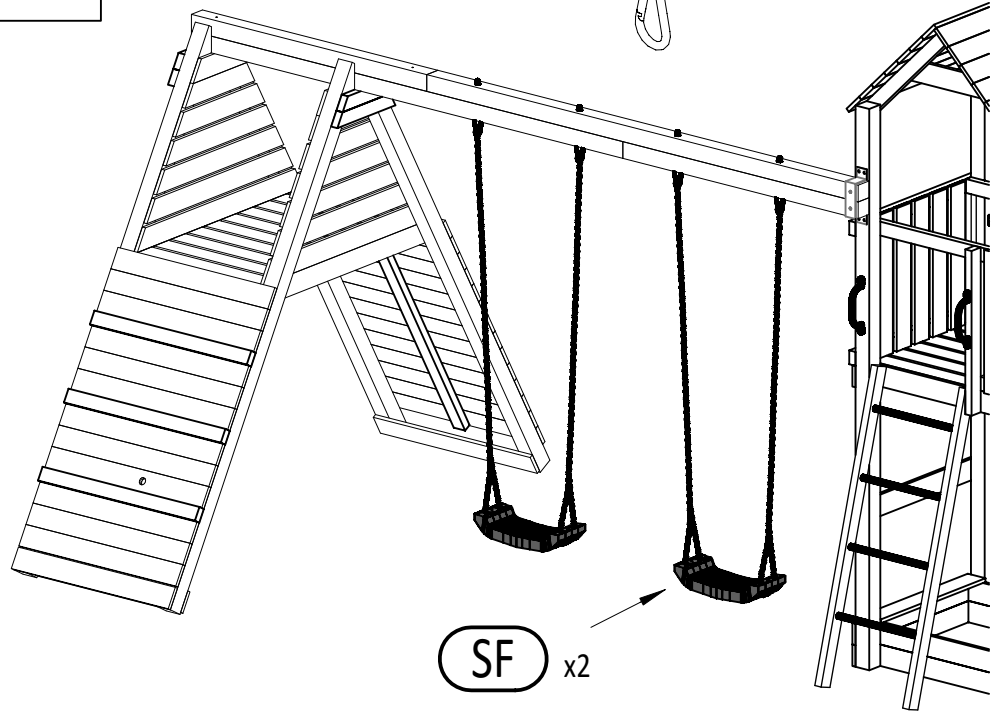
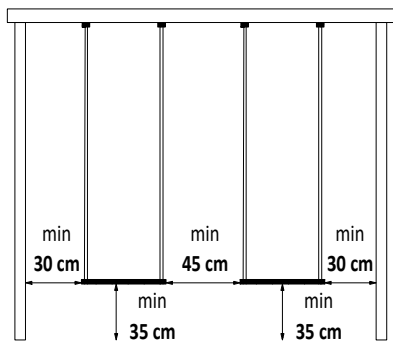
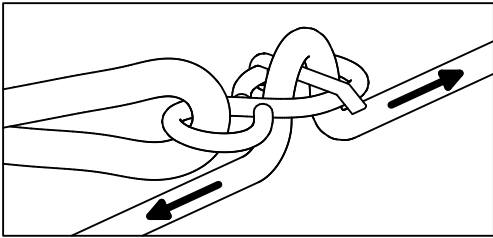

M12 x4

41

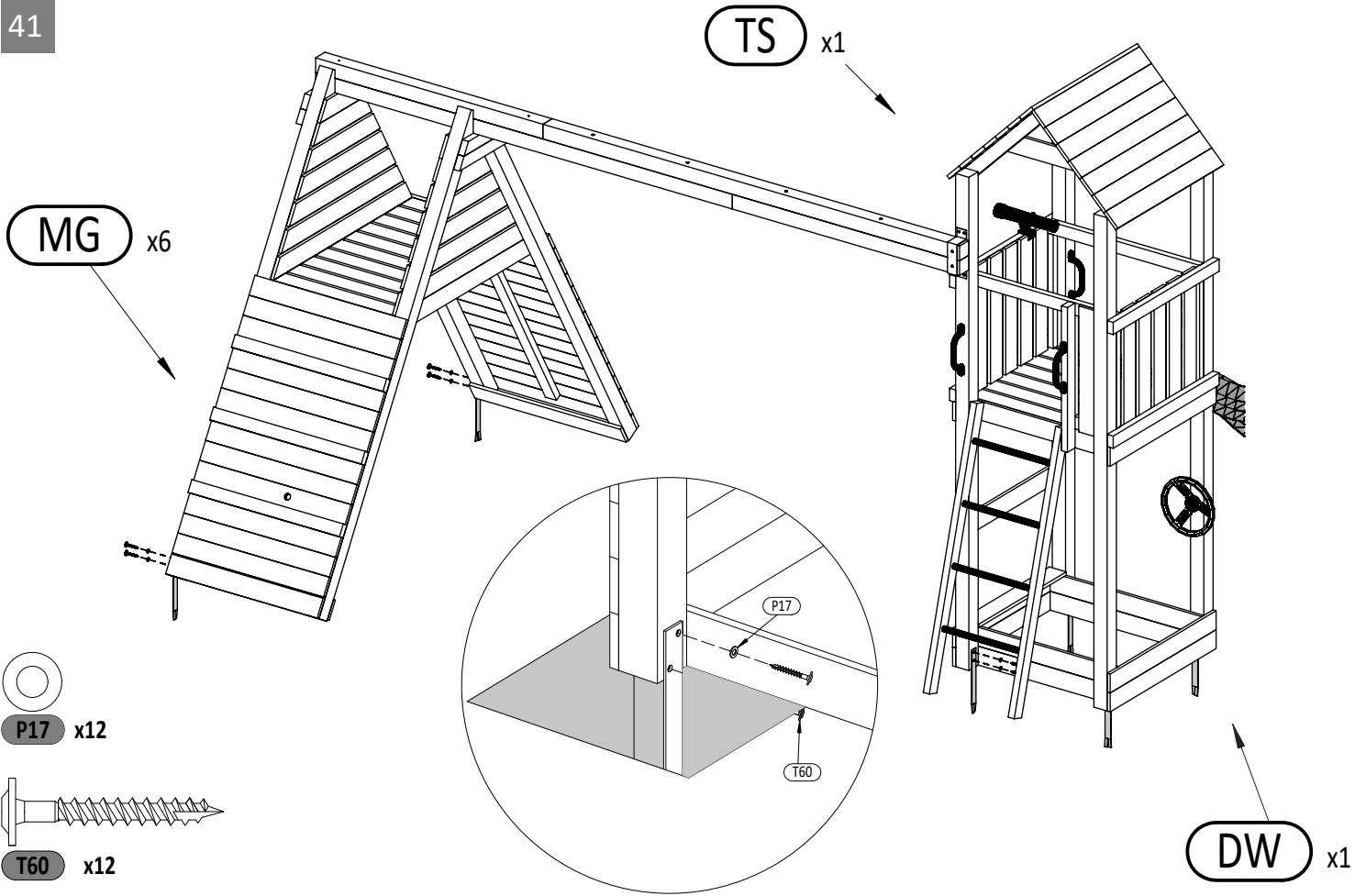

42

