

URBAN/CITY KRATKA DEKORACYJNA

Nr	Schemat	Rozmiar
K1		19X462 L=1727 mm

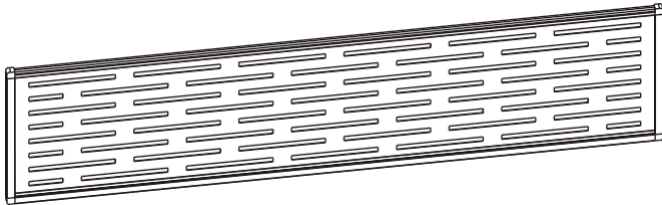

PL: Zdejmij nasadkę, wyjmij śruby mocujące po obu stronach i zdemontuj trzy deski.

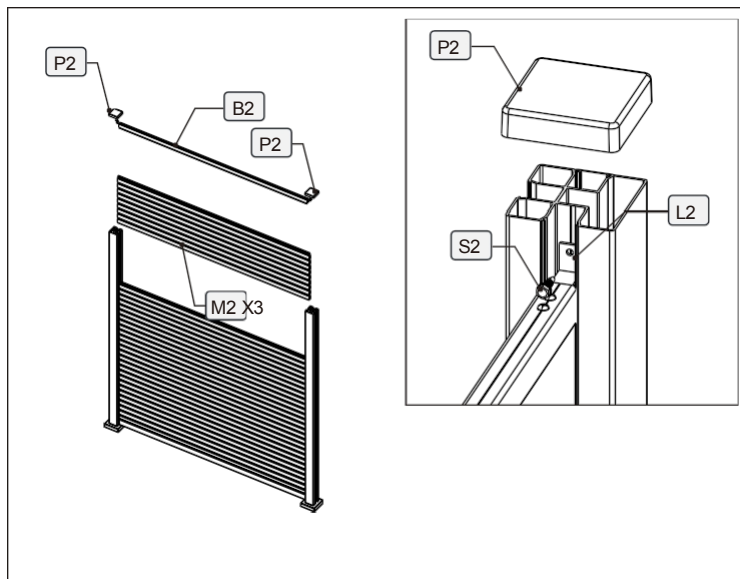
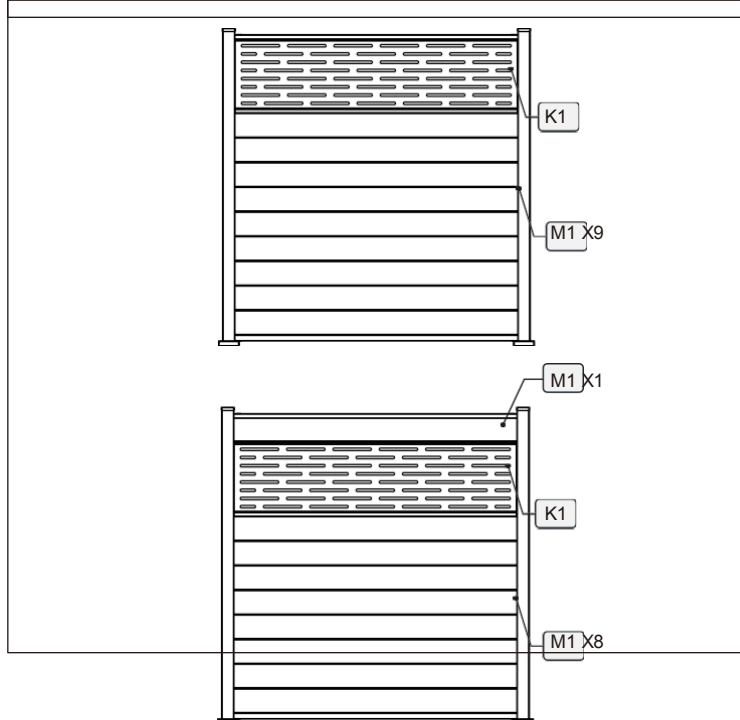

PL: Wsuń panel dekoracyjny w kolumny i zamontuj górną listwę krawędziową.

INSTALLATION GUIDE URBAN/CITY DECO TRELLIS

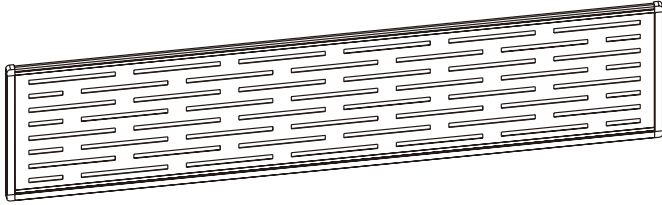
No.	Diagram	Size
K1		19X462 L=1727mm

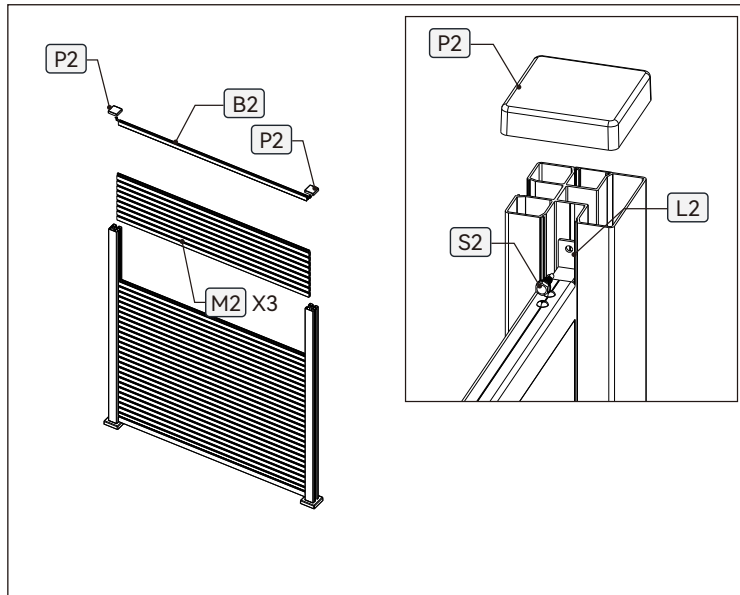

EN: Remove the cap, take out the mounting screws on both sides, and detach the three plates.

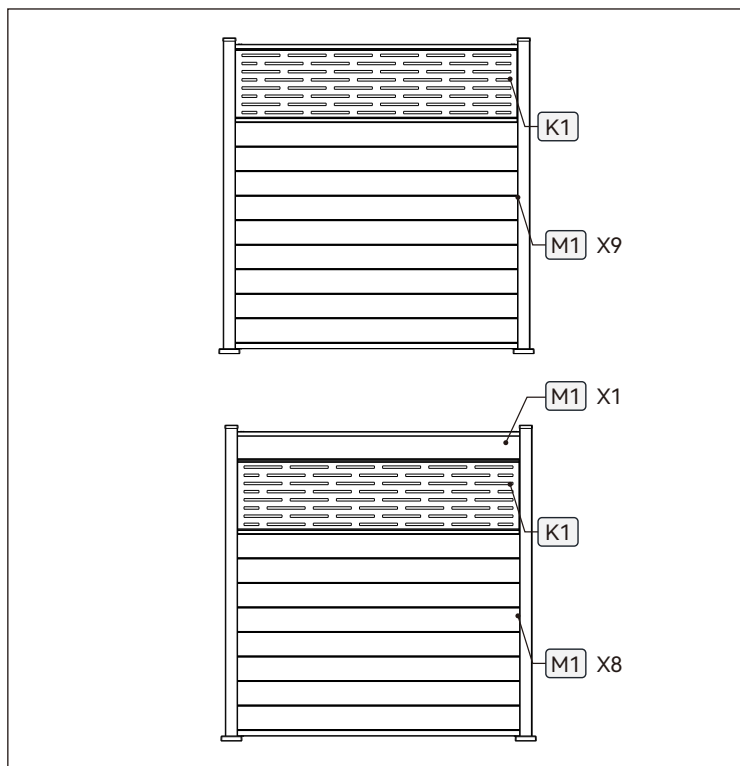

EN: Slide the decorative panel into the column and install the top edge banding.