



Aluminium PC Greenhouse

W305 x L607x H247cm

Szklarnia aluminiowa z poliwęglanu

szer. 305 x dł. 607 x wys. 247 cm

ASSEMBLY
INSTRUCTION
INSTRUKCJA
MONTAŻU



IMPORTANT!

Please read all instructions carefully!
It is best to familiarize yourself with
the appropriate parts for each step.
Przed montażem należy dokładnie
Rekomendujemy zapoznać się z
odpowiednie elementy do każdego

PLATFORM PODSTAWA

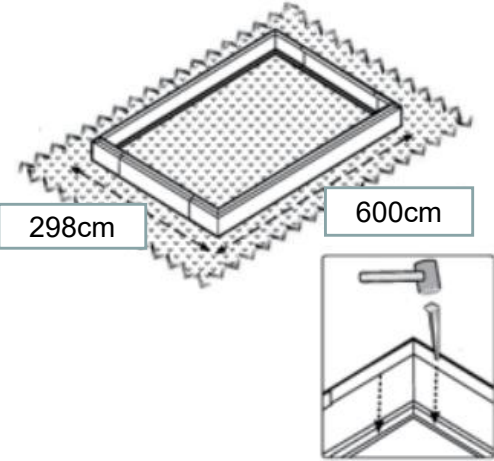
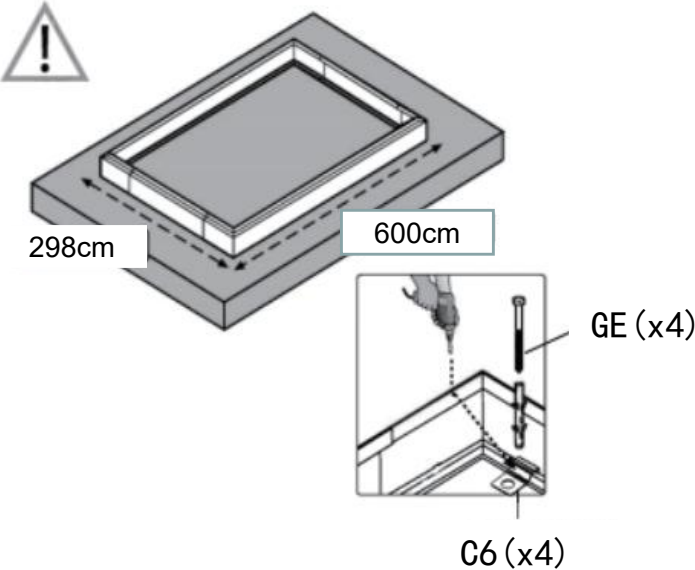
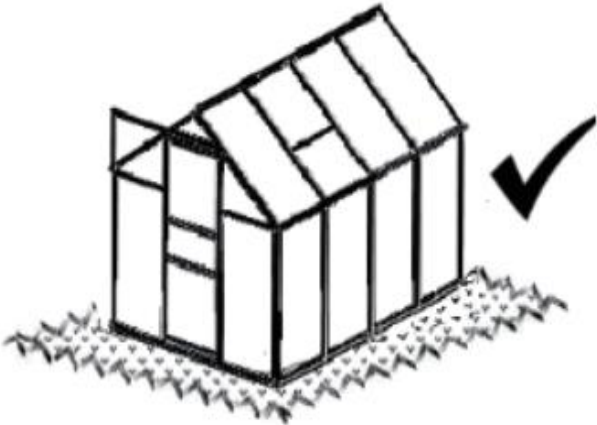

SAFETY ADVICE

We strongly recommend the use of work gloves during assembly. Always wear shoes and safety goggles when working with extruded aluminum. Do not attempt to assemble the Aluminum Greenhouse in windy or wet conditions. The Aluminum Greenhouse must be positioned and fixed on a flat level surface. Ensure there are no hidden pipes or cables in the ground before inserting the pegs. Do not position your Aluminum Greenhouse in an area exposed to excessive wind. Do not lean against or push the Aluminum Greenhouse during construction. Do not touch overhead power cables with the aluminum profiles. Keep children away from the assembly area. Do not attempt to assemble this Aluminum Greenhouse if you are tired, have taken drugs, alcohol or if you are prone to dizzy spells. Dispose of all plastic bags safely and keep them out of reach of children. If using a step ladder or power tools ensure that you follow the manufacturer's safety advice. Hot items such as recently used grills, blowtorches etc. must not be stored in the wall shed.

ZASADY BEZPIECZEŃSTWA

Aby zapobiec obrażeniom, podczas montażu konieczne jest noszenie rękawic ochronnych, okularów ochronnych oraz obuwia i odzieży roboczej z długim rękawem. Nie należy montować szklarni podczas wietrznych, mokrych i niekorzystnych warunków pogodowych. Montaż powinien się odbywać w suchy, spokojny i pogodny dzień. Szklarnia musi być ustawiona i zamocowana na płaskiej, równej oraz stabilnej powierzchni, dodatkowo należy ją zakotwiczyć do podłoża, aby uniknąć porwania przez wiatr. Przed rozpoczęciem montażu należy upewnić się, że w ziemi nie ma ukrytych rur lub kabli. Szklarnie należy ustawić w miejscu, które jest dobrze osłonięte przed działaniem wiatru. Podczas montażu nie należy popychać ani opierać się o konstrukcję szklarni. Bezwzględnie należy unikać kontaktu profili aluminiowych z napowietrznymi kablami instalacji elektrycznej. Zabrania się wstępu na obszar budowy dzieci, osób niepełnoletnich, osób niepełnosprawnych, osób nietrzeźwych lub pod wpływem środków odurzających oraz zwierząt. Prosimy w bezpieczny sposób zutylizować wszystkie plastikowe opakowania i trzymać je poza zasięgiem dzieci.

Używając podczas montażu drabiny lub narzędzi elektrycznych, należy przestrzegać zasad bezpieczeństwa wskazanych przez producenta. Gorące przedmioty, takie jak niedawno używany grill, palniki i inne, nie mogą być stawiane i przechowywane w pobliżu paneli poliwęglanowych.

GENERAL ADVICE

This is a multi-part assembly, allow at least 3-4 hours for assembly. In selecting a site-choose a sunny level position away from overhanging trees and well protected against the wind. If you are fixing your Aluminum Greenhouse directly to a solid concrete foundation use the pre-drilled holes in the metal base supplied. The component parts should be checked and laid out close at hand. Keep all small parts (screws etc) in a bowl so they do not get lost. Keep roof clear of snow and leaves.

WSKAZÓWKI OGÓLNE

Szklarnia przeznaczona jest do montażu wieloetapowego, na pracę należy przeznaczyć co najmniej 3-4 godziny. Szklarnie należy ustawić w dobrze naświetlonym miejscu z dala od gałęzi drzew, które jest jednocześnie dobrze chronione przed nadmiernym wiatrem. W przypadku mocowania szklarni bezpośrednio do betonowego fundamentu należy użyć wstępnie wywierconych otworów w dostarczonej metalowej podstawie. Części składowe powinny być sprawdzone, pogrupowane i rozłożone w zasięgu ręki. Wszystkie drobne części (takie jak śruby, itp.), aby się nie zgubiły, rekomendujemy trzymać w odpowiednim naczyniu. Dach szklarni należy bezwzględnie oczyszczać ze śniegu, liści i innych zanieczyszczeń.

CARE & MAINTENANCE

When your aluminum greenhouse needs cleaning, use a mild detergent solution and rinse. Do NOT use acetone, abrasive cleaners or other special detergents to clean the clear panels.

KONSERWACJA I PIELEGNACJA

Kiedy szklarnia wymaga czyszczenia, prosimy używać wyłącznie łagodnego detergentu, a na koniec spłukać wodą. NIE NALEŻY używać acetonu, środków ściernych lub innych środków czyszczących na bazie rozpuszczalników do czyszczenia paneli poliwęglanowych.

TOOL&EQUIPMENT NARZĘDZIA I WYPOSAŻENIE

Protective Equipment

Sprzęt ochronny

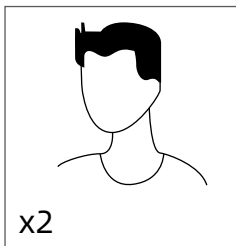

- 2 people needed
- Wymagane 2 osoby

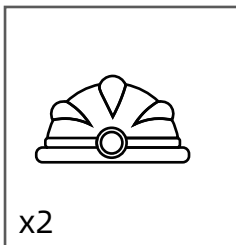

- Safety Helmet
- Kask ochronny

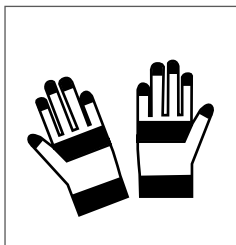

- Gloves
- Rękawiczki ochronne

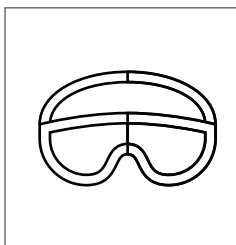

- Goggles
- Okulary ochronne

Measuring Tools & Installation Equipment

Narzędzia i sprzęt montażowy

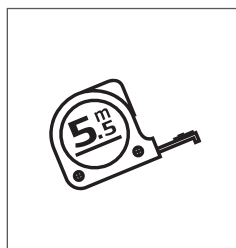

- Tape Measure
- Miara

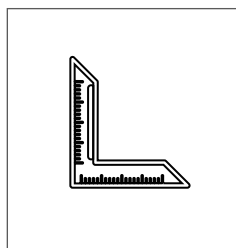

- Angle Rule
- Kątomierz

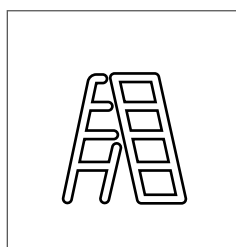

- Triangular Ladder
- Drabina

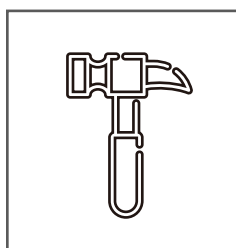

- Mallet
- Młotek gumowy

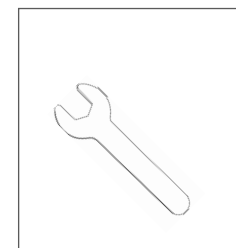

- SpannerC10
- Klucz płaski 10

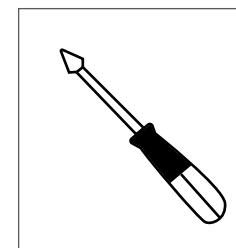

- Cross Screwdriver
- Śrubokręt krzyżowy

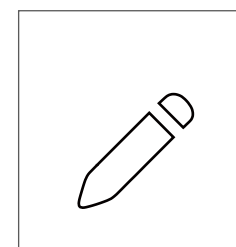

- Marking Pen
- Marker

BEFORE ASSEMBLY

PRZED MONTAŻEM

1. Selecting a site.

The product must be positioned and fixed on a flat level surface.

Choose a sunny position away from overhanging trees.

1. Wybór miejsca instalacji.

Szklarnię należy ustawić i zamocować na płaskiej, równej i stabilnej powierzchni.

Miejsce powinno być dobrze naświetlone, z dala od gałęzi drzew i jednocześnie dobrze chronione przed nadmiernym wiatrem.

2. We strongly recommend this product to be secured directly to a solid foundation.

2. Zdecydowanie zalecamy, aby szklarnia była montowana bezpośrednio do solidnego fundamentu.

3. The multi-part assembly is better achieved by two people. Allow at least half day for the assembly process.

3. Montaż powinien być wykonywany przez dwie osoby. Na pracę należy przeznaczyć co najmniej pół dnia.

4. Take all components & parts out of the packages. Sort the parts and check against the content parts list.

4. Prosimy wyjąć wszystkie komponenty i części z opakowań, posortować je i sprawdzić z listą części.

5. Parts should be laid out close at hand. Keep all small parts(screws etc.) in a bowl so they do not get lost.

5. Części powinny być ułożone w zasięgu ręki. Wszystkie drobne części (takie jak śruby, itp.), aby się nie zgubiły, rekomendujemy trzymać w odpowiednim naczyniu.

6. Please note multi-holes profiles are used in this. As a result some holes in the profiles are not used during assembly.

6. Prosimy zauważyć, że profile stosowane do budowy szklarni są wielostronne. W związku z tym niektóre otwory w profilach mogą pozostać niewykorzystywane podczas montażu.



7. Please review entire instructions before starting. Carry out the assembly steps in exact order.



7. Przed rozpoczęciem pracy należy dokładnie zapoznać się z instrukcją. Prosimy postępować krok po kroku wg przedstawionej kolejności.

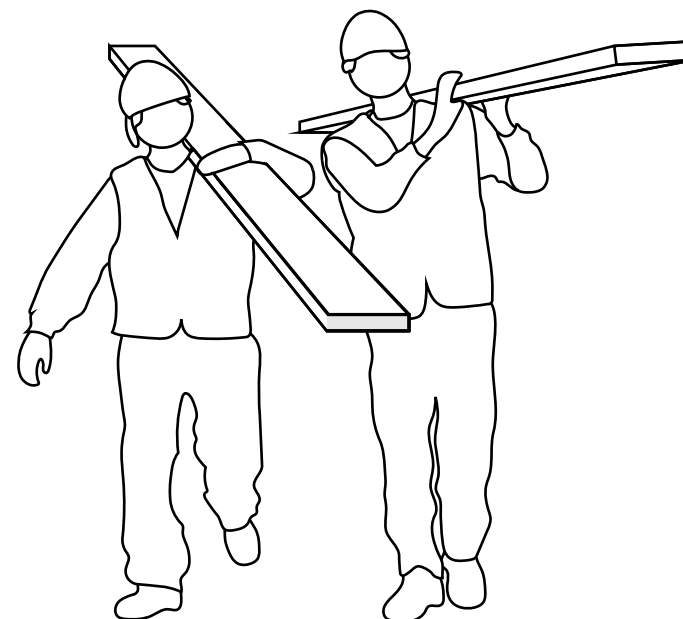



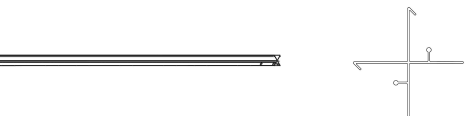
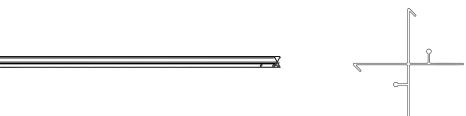
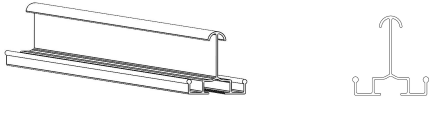
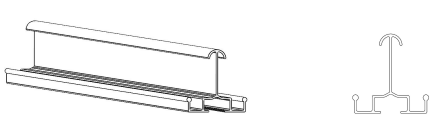

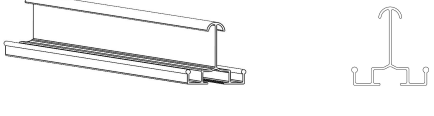
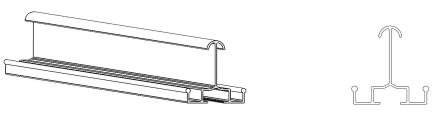
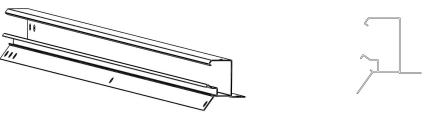
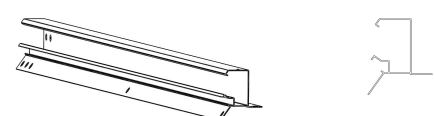
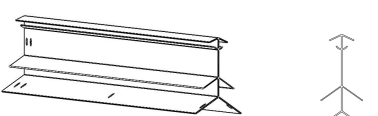
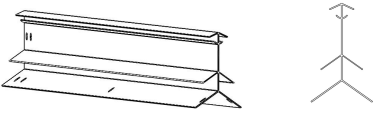

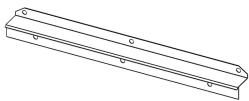
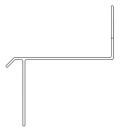
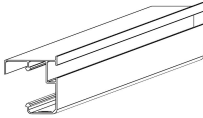
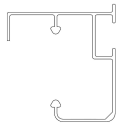

8. Please consult your local authorities if any permits are required prior to constructing the product.

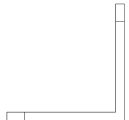

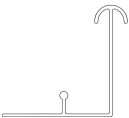

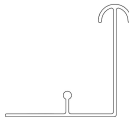
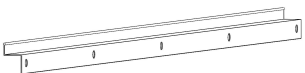





8. Jeśli przed rozpoczęciem budowy szklarni wymagane są jakiegokolwiek pozwolenia, prosimy skonsultować się z lokalną administracją.



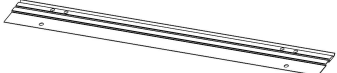

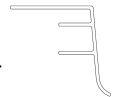

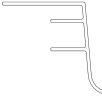
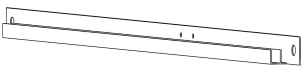
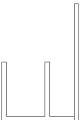

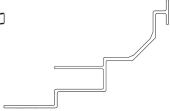

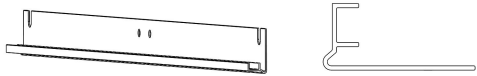
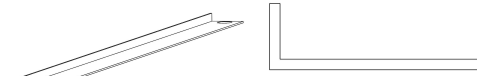
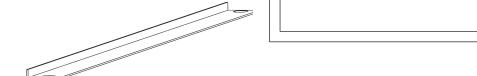
code Kod		Qty Ilość
A1		4
A2R		1
A2L		1
A3L		1
A3R		1
A4		18
A5L		1



code Kod		Qty Ilość
A5R		1
A6		18
A7		2
A8		2
A9		1
A10		1
A11		4



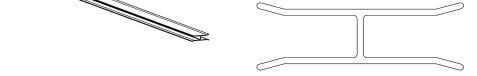

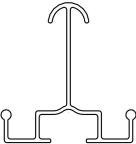
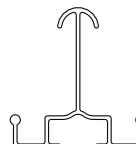
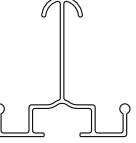
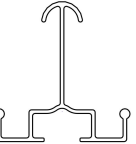
code Kod		Qty Ilość
A12	 	1
A13	 	2
A14	 	2
A15L	 	1
A15R	 	1
A16	 	1
A17	 	2

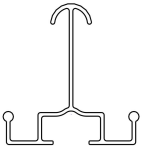
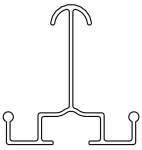
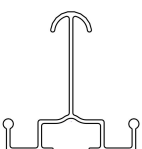
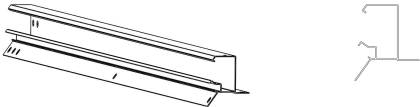
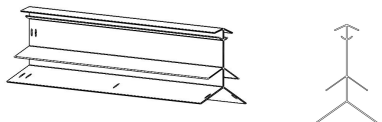

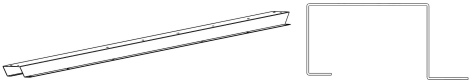
code Kod		Qty Ilość
A18	 	2
A19	 	2
A20	 	2
A21L	 	4
A21R	 	4
A22	 	4
A23	 	4

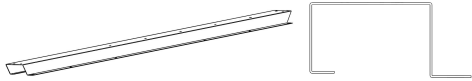

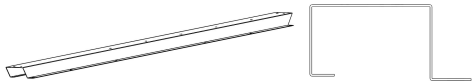

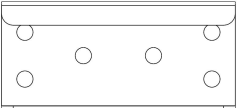
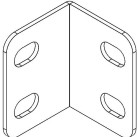

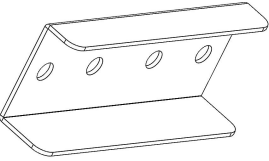
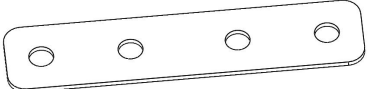
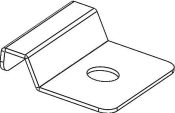
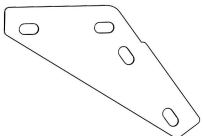
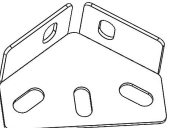
code Kod		Qty Ilość
A24		4
A25		2
A26		1
A27		1
A28		2
A29		2
A30		10



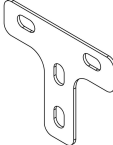

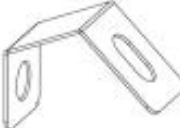
code Kod		Qty Ilość
A31		4
A32		4
A33		5
A34L		1
A34R		1
A35L		1
A35R		1

code Kod		Qty Ilość
A36L		1
A36R		1
A37		6
A38		2
A39		1
33S1		1
33S2		1

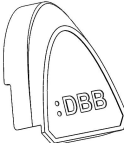

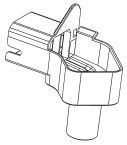
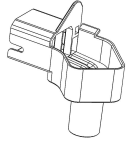
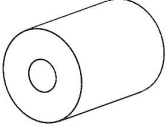

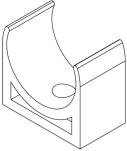
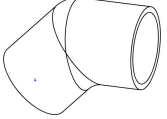
code Kod		Qty Ilość
33N1		1
33N2		1
33E1		2
33E2		2
33E3		2
C1		6
C2		4

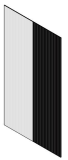
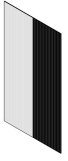
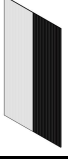
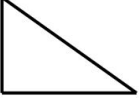
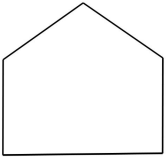
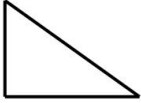
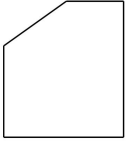

code Kod		Qty Ilość
C3		2
C4		4
C5		6
C6		6
C7		4
C8		2
C9		6

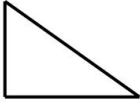
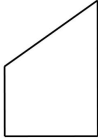

code Kod		Qty Ilość
C10		2
C11		52
C12		4
C13		9
C14		10
C15		8
R1		2

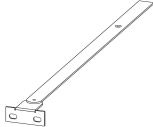

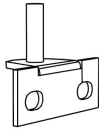
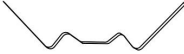
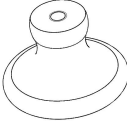
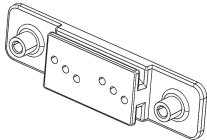
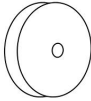
code Kod		Qty Ilość
R2		2
R3		2
R4		2
R5		4
R6		4
R7		4
P1		4

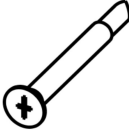
code Kod		Qty Ilość
P2		20
P3		16
P4		5
P5		2
P6		1
P7		2
P8		2

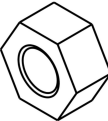
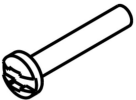
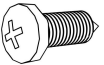
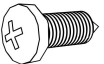
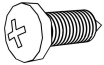
code Kod		Qty Ilość
P9		1
P10		2
P11		2
P12		4
P13		4
P14		4
B1		8

code Kod		Qty Ilość
B2		8
B3		490
B4		2
S1		4
S2		8
F2		10
F3		8

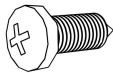
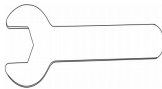
code Kod		Qty Ilość
F4		420
F5		422
F6		2
F7		37
F8		16
F9		26
F10		12

code Kod		Qty Ilość
F11		4
F12		2
GE		6

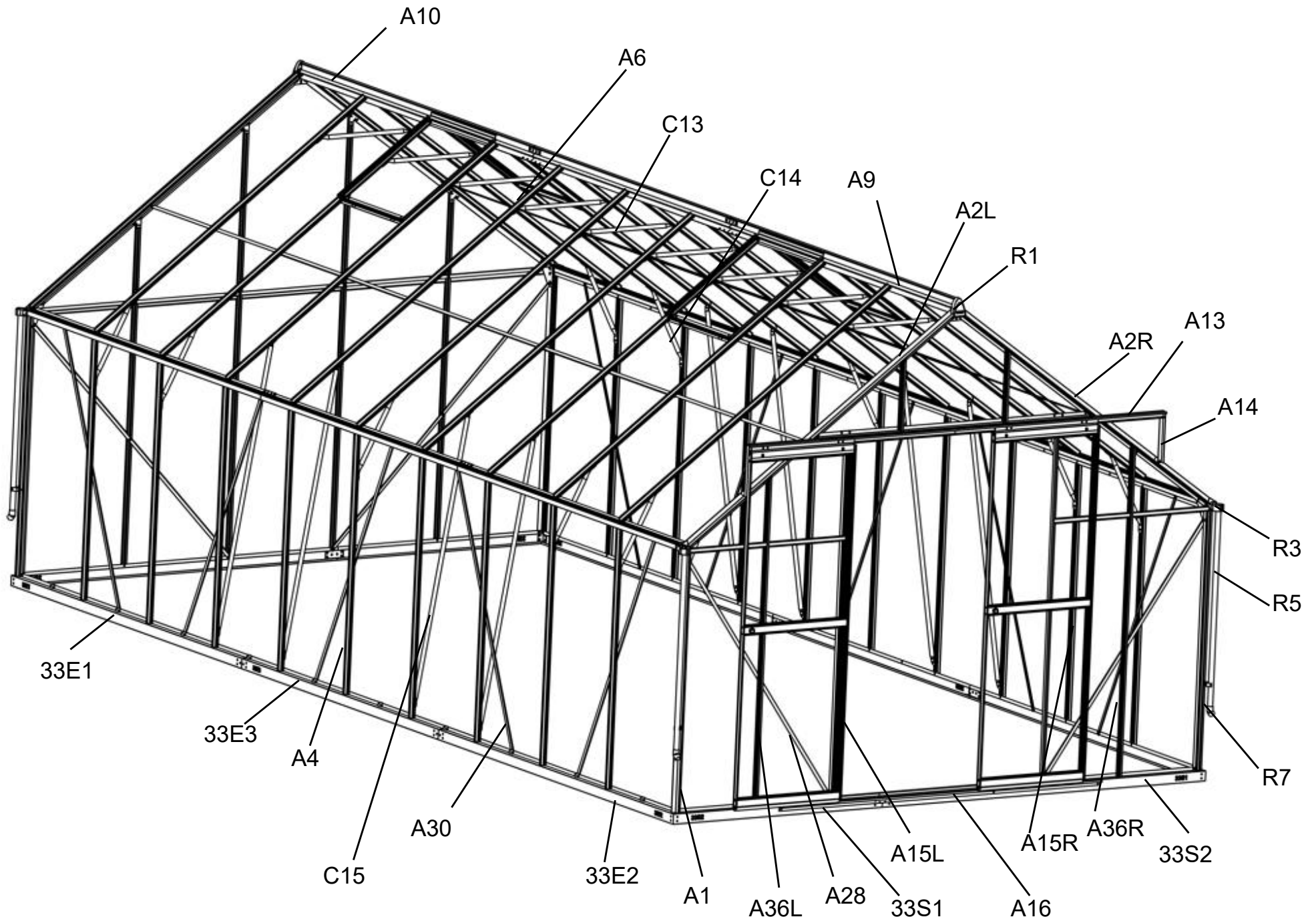

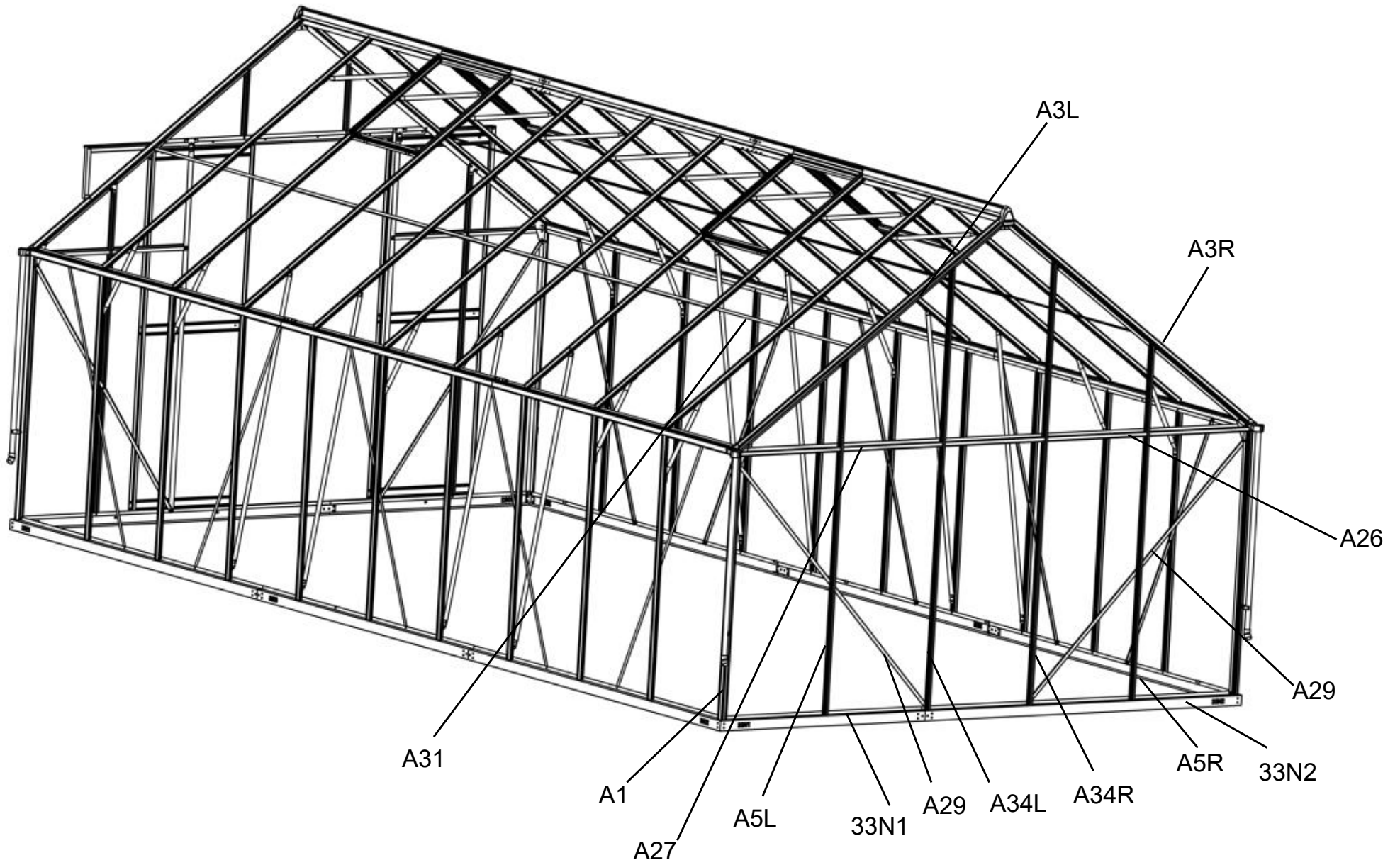

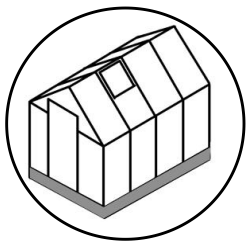



code Kod		Qty Ilość
33N1		1
33N2		1
33E1		2
33E2		2

code Kod		Qty Ilość
33S1		1
33S2		1

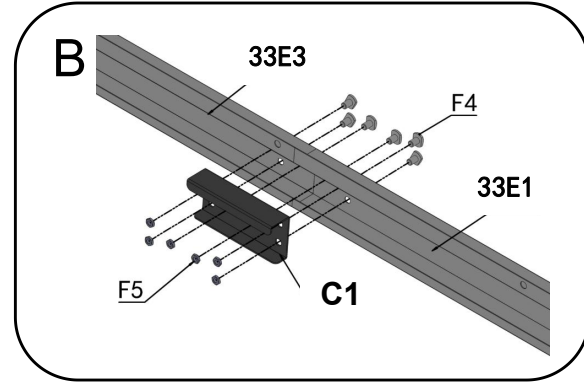
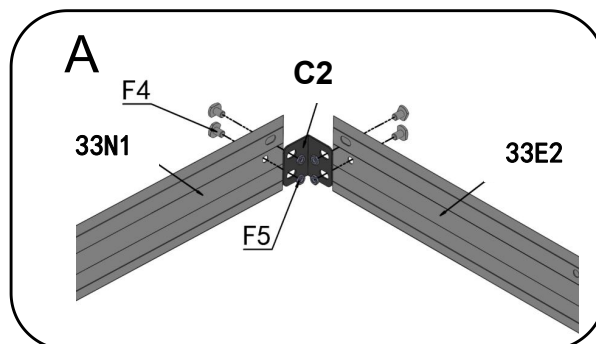
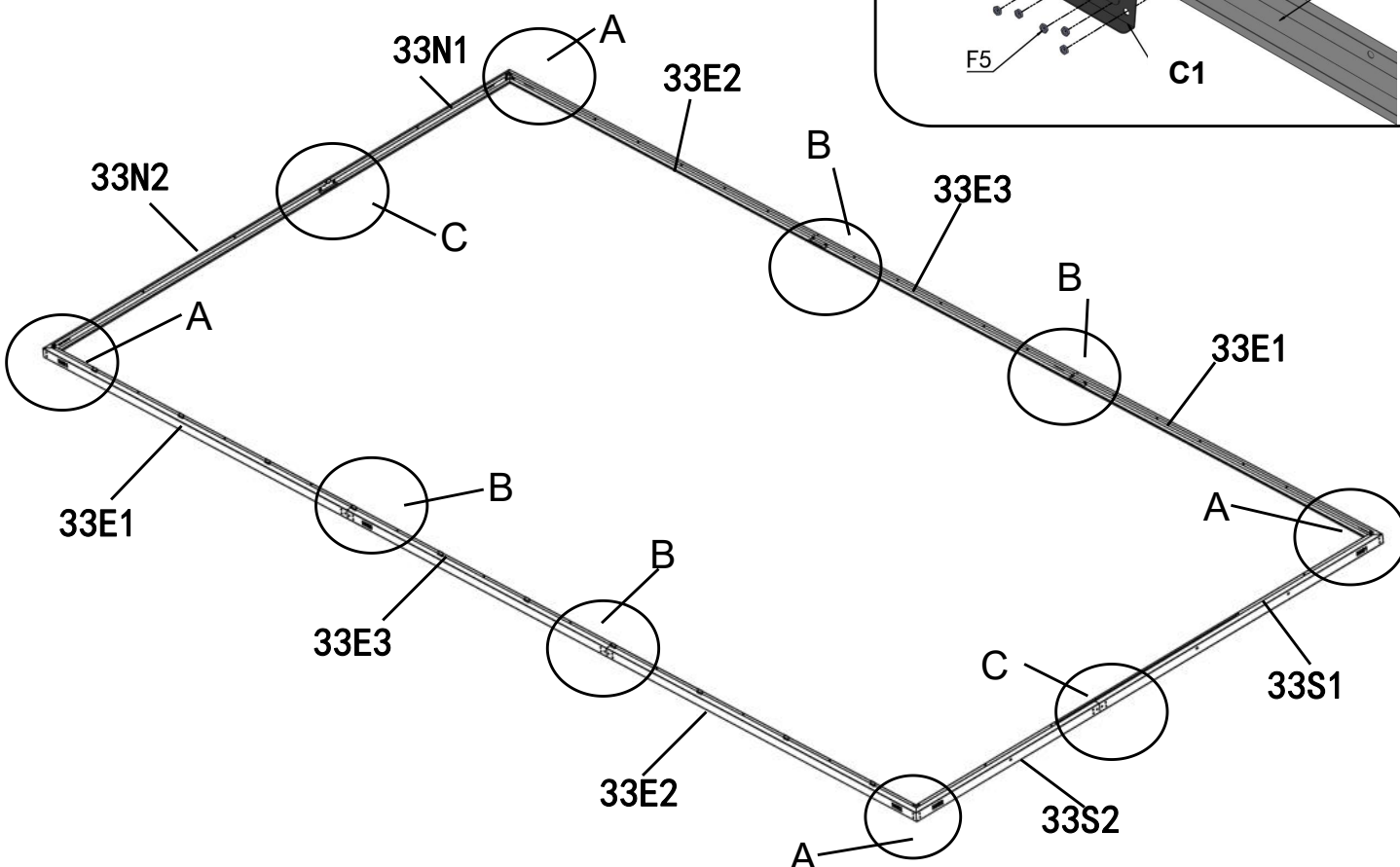
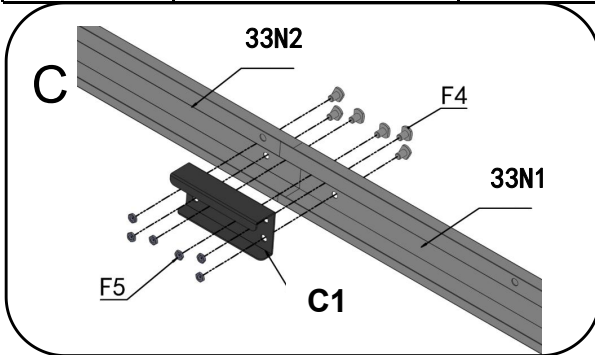
code Kod		Qty Ilość
F4		40
F5		40
C1		6
C2		4
33E3		2

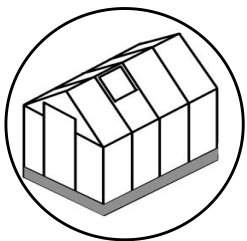

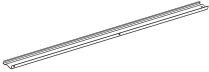

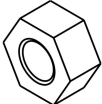

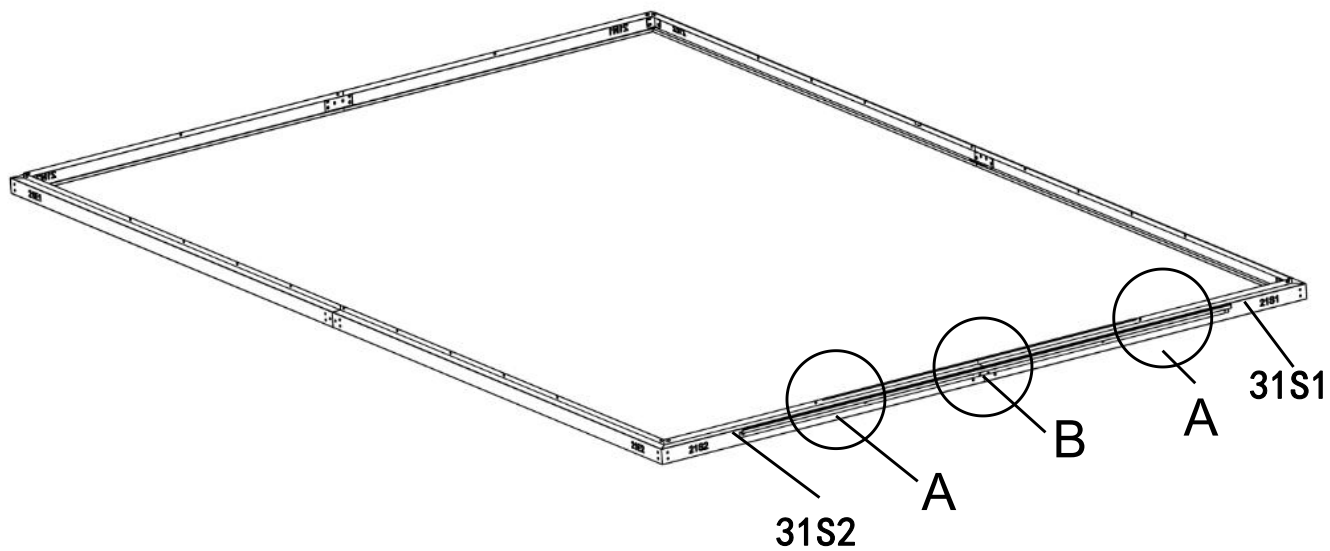
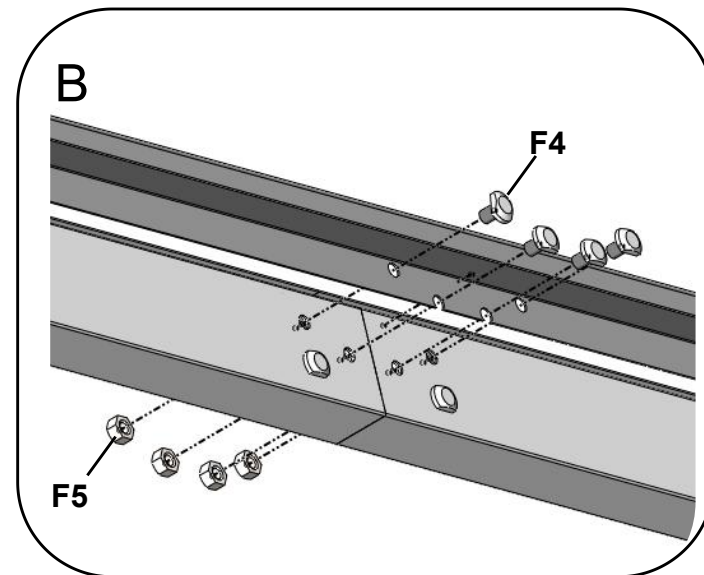
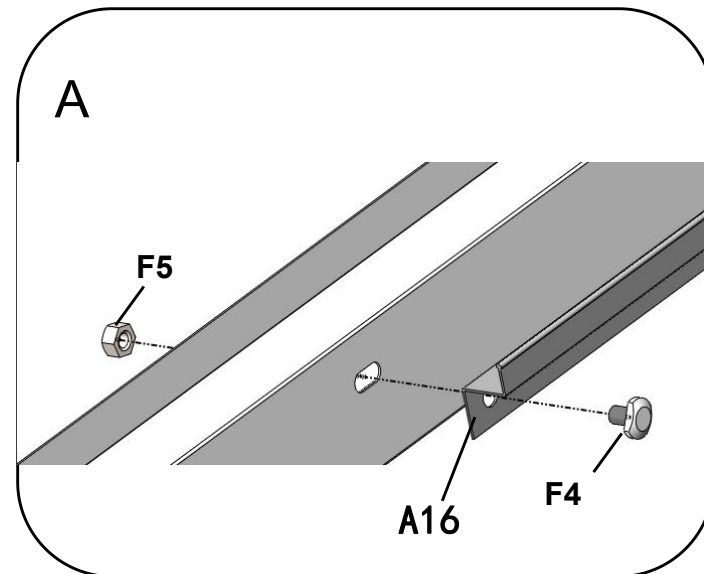
code Kod		Qty Ilość
A16		1
F4		4
F5		4

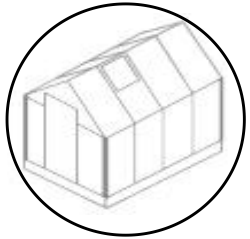





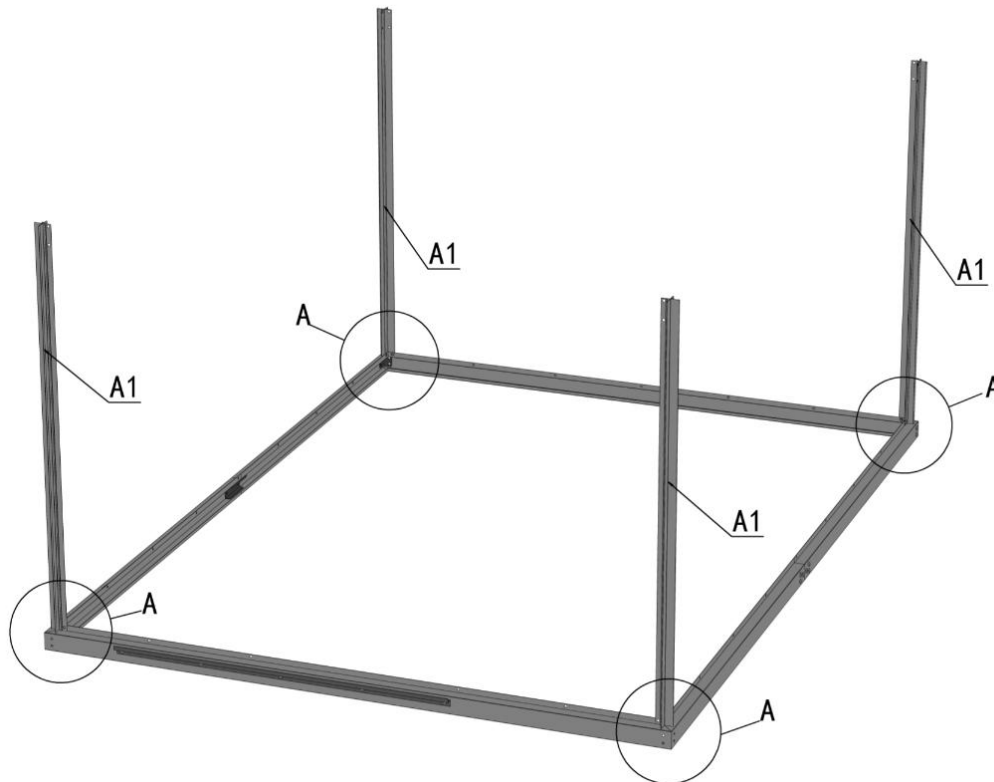
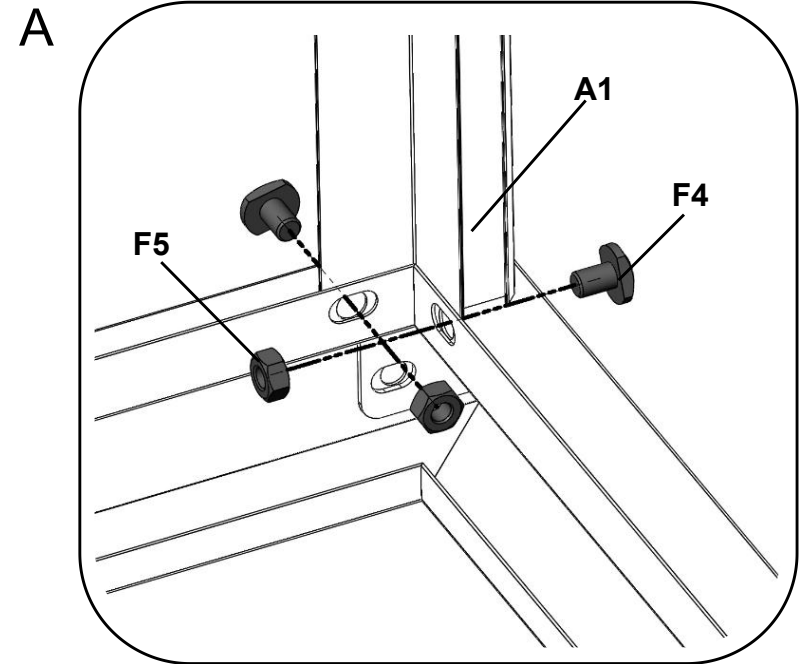

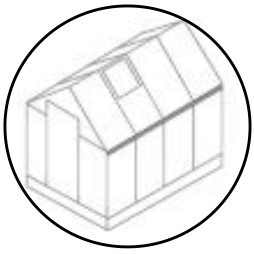

code Kod		Qty Ilość
A1		4
F4		8
F5		8





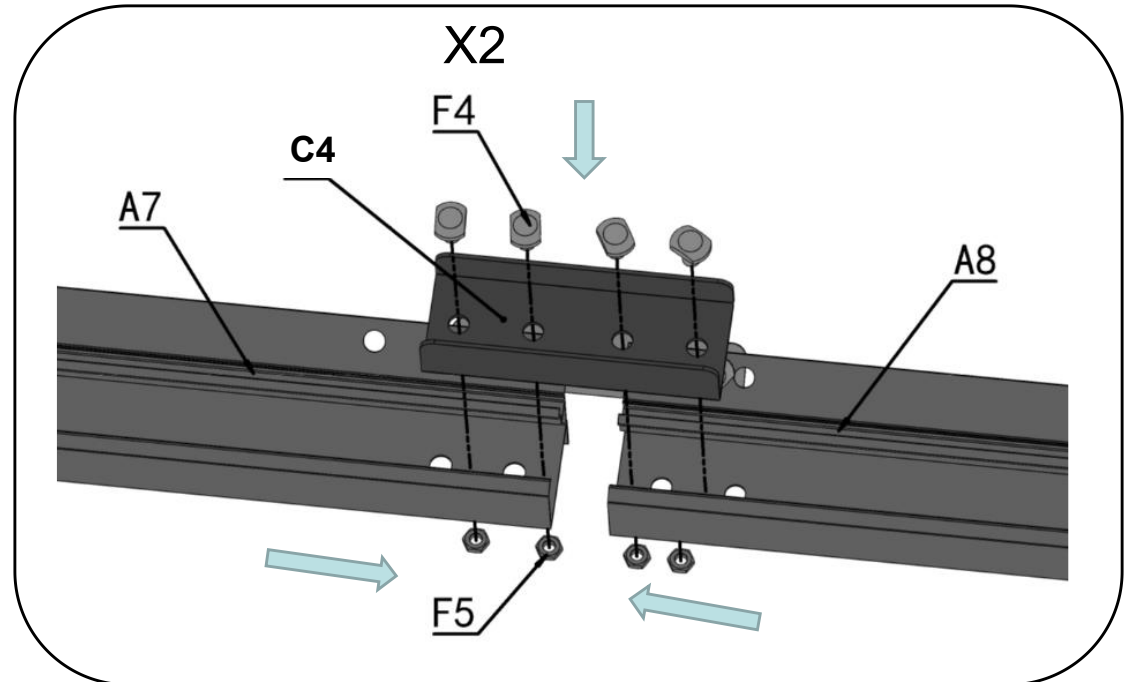
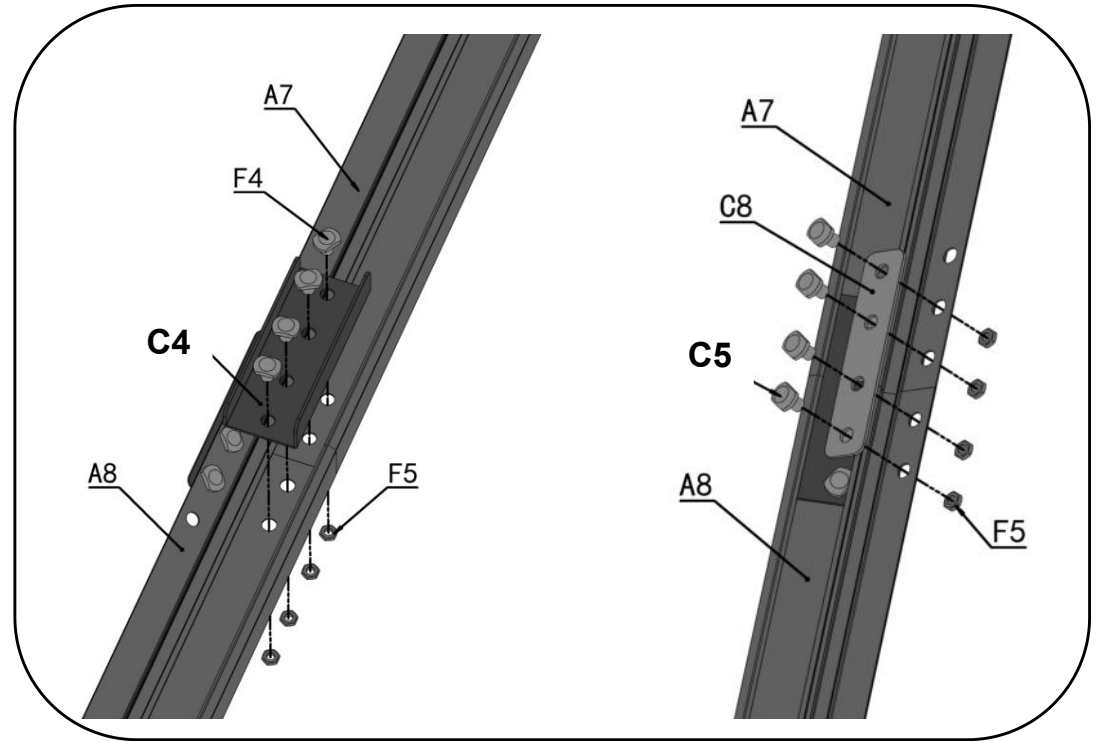

code Kod		Qty Ilość
A7		2
A8		2
C5		4
C4		4
F4		32
F5		32
A38		2





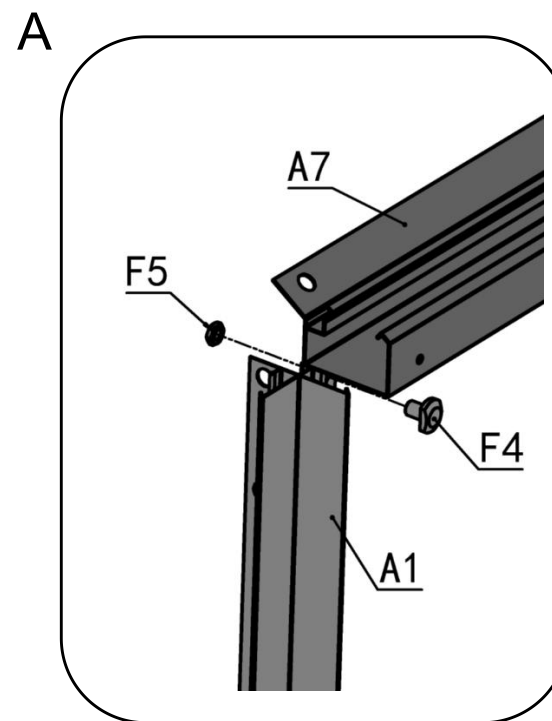
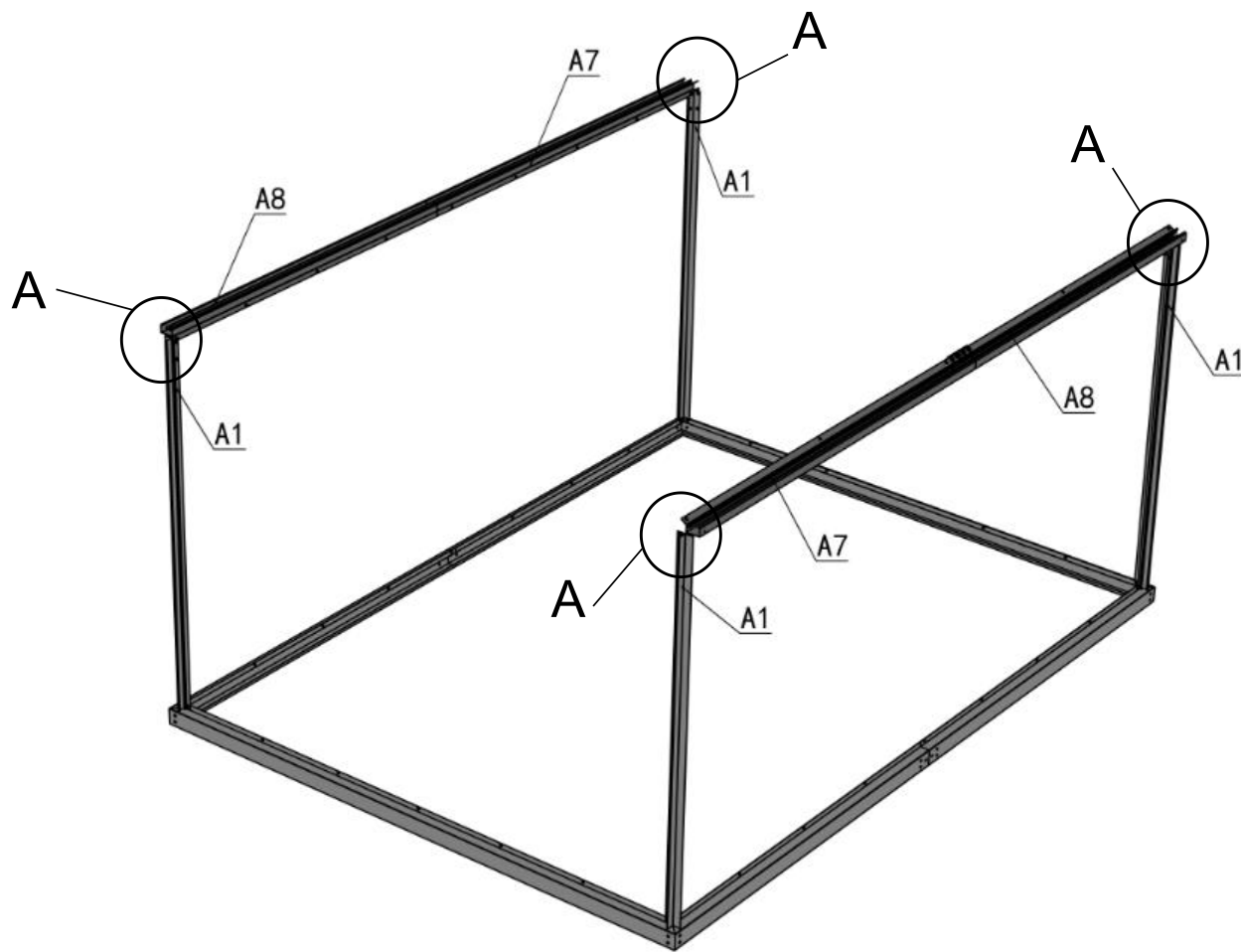

code Kod		Qty Ilość
F4		4
F5		4

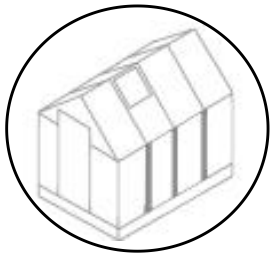

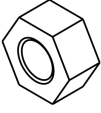

code Kod		Qty Ilość
A4		18
F4		46
F5		36

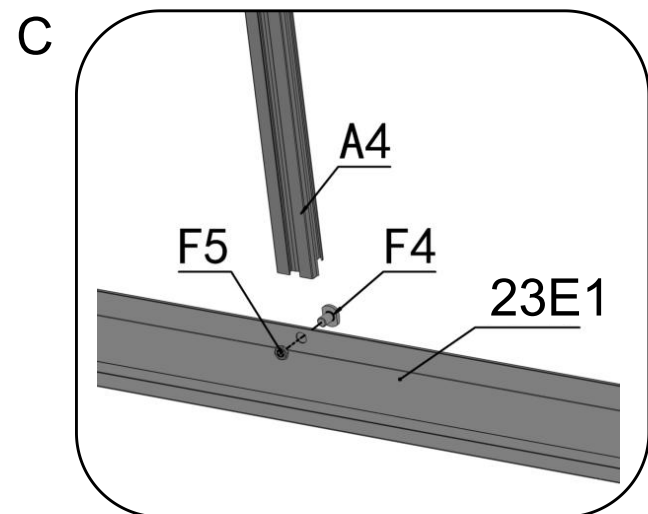
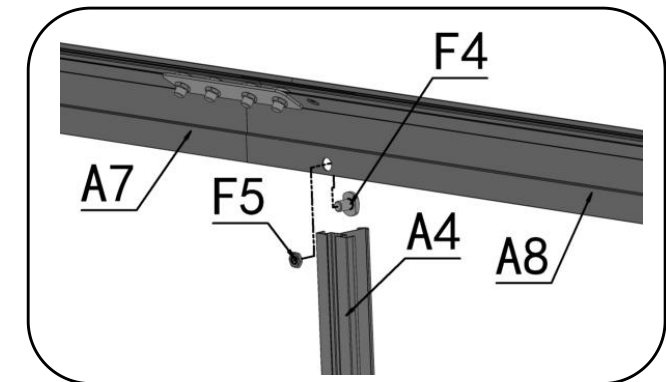
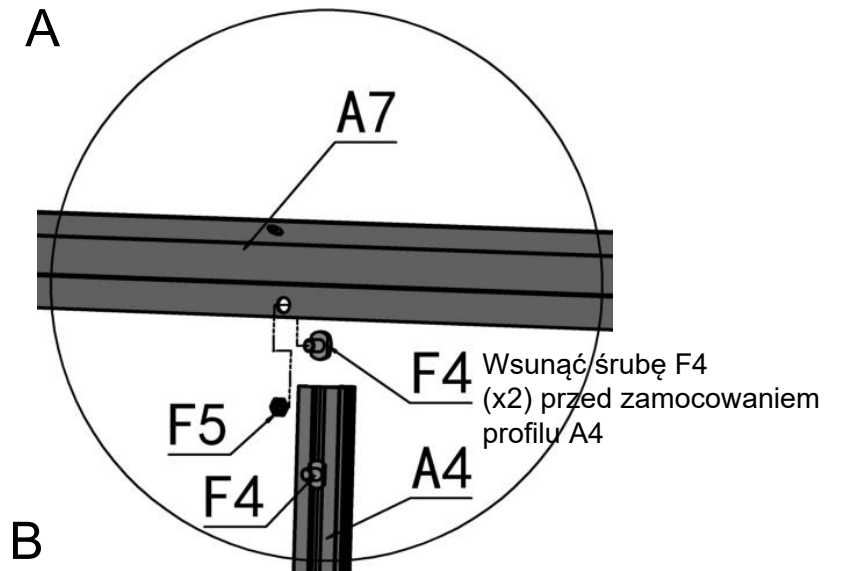
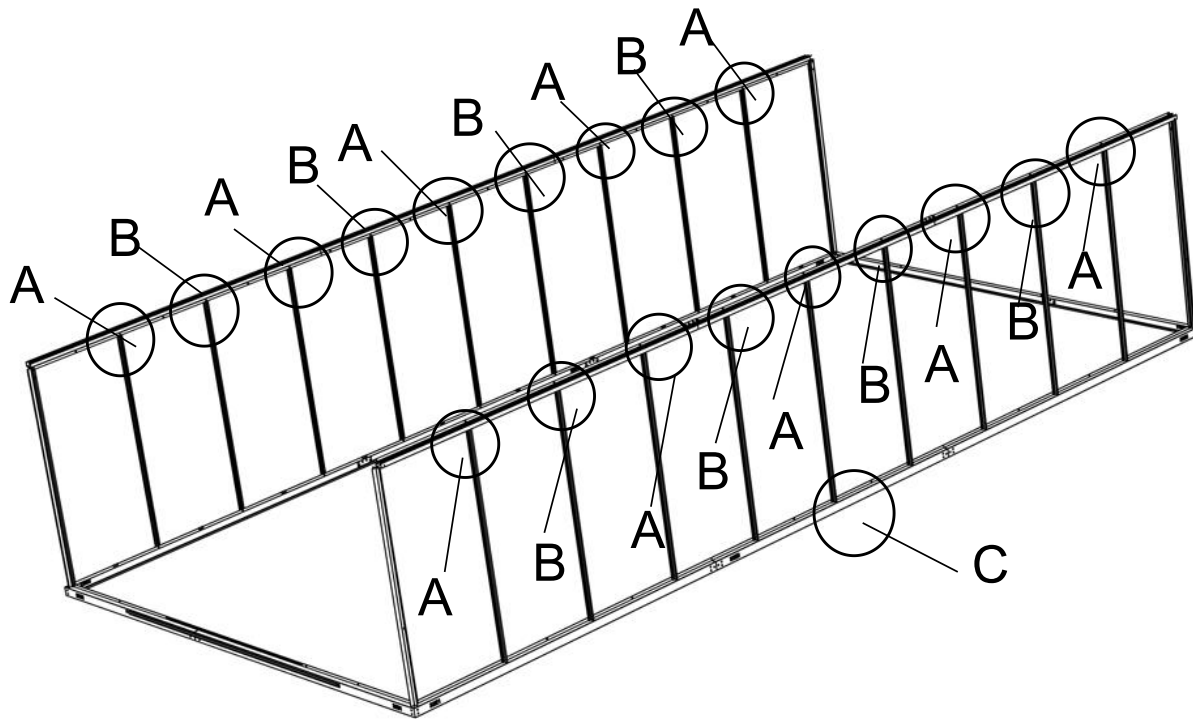

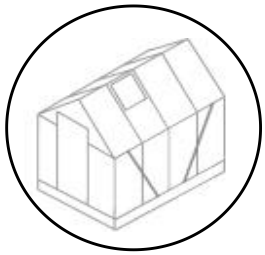



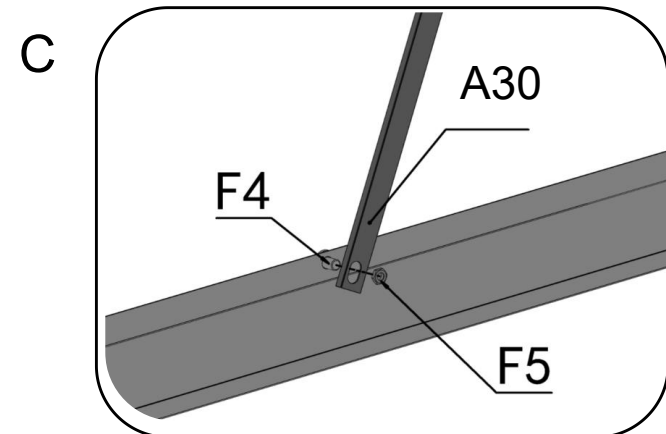
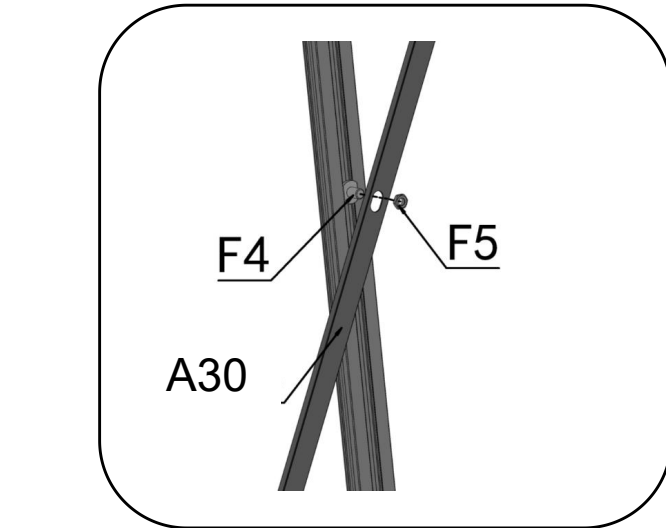
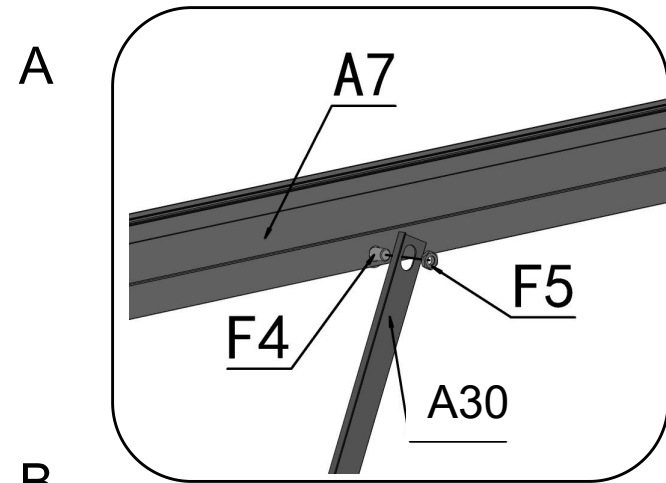
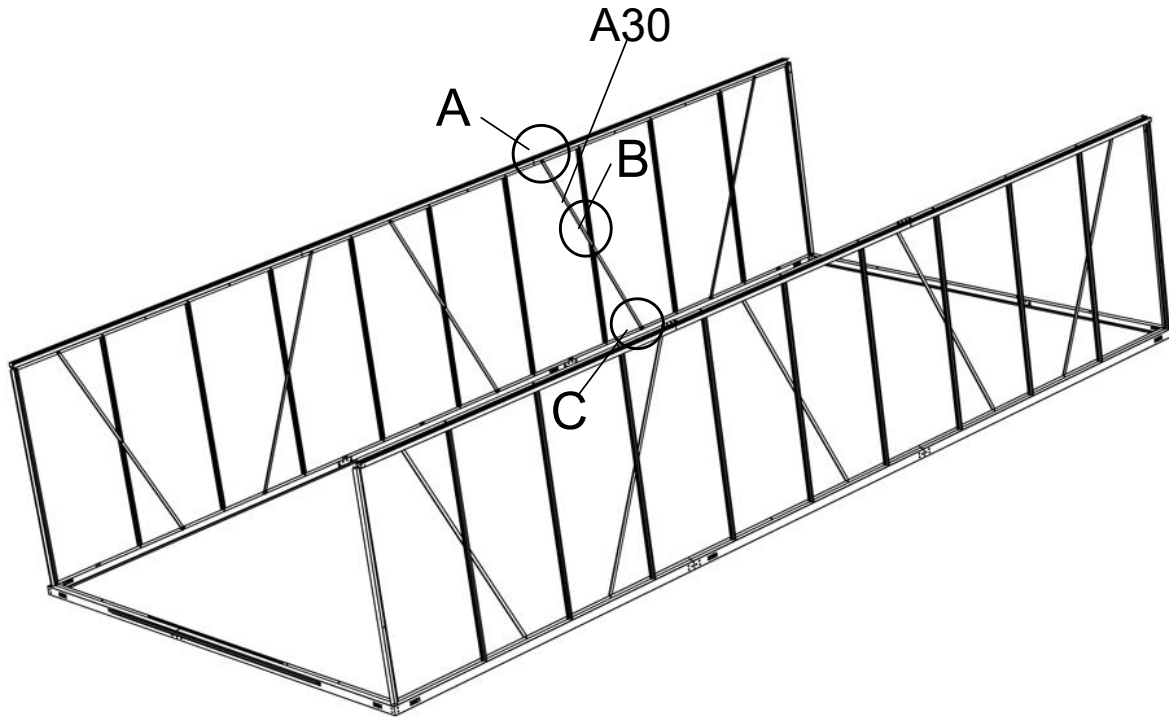

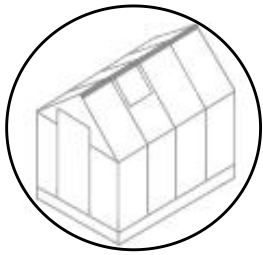

code Kod		Qty Ilość
F4		20
F5		30
A30		10







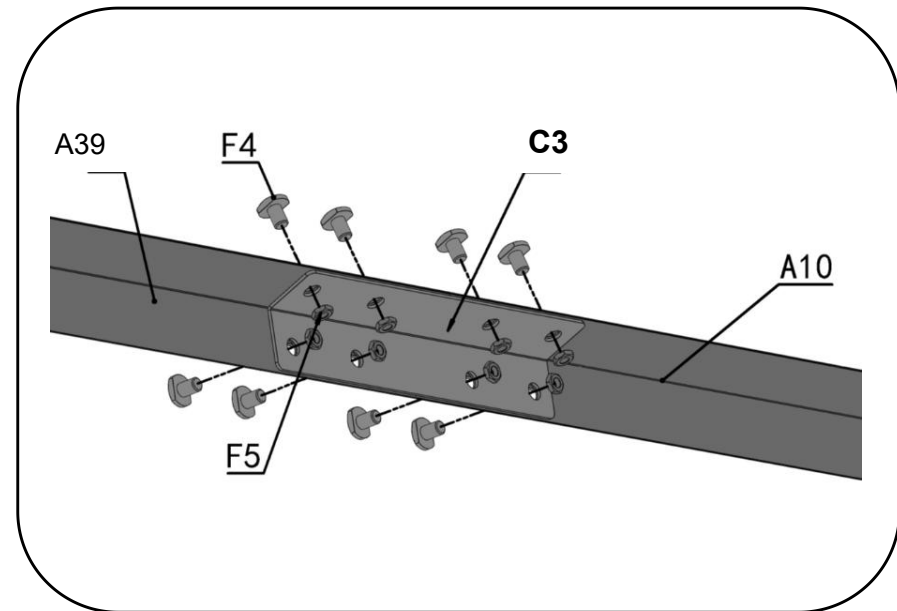
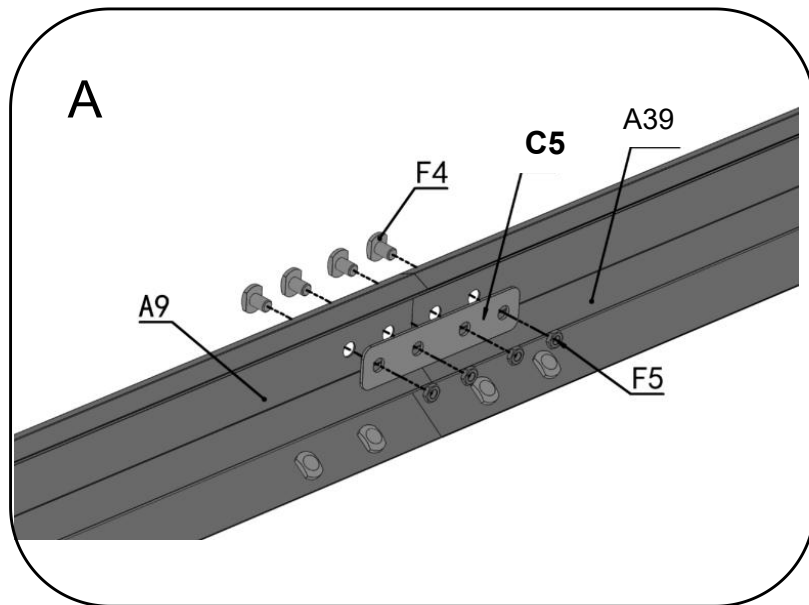
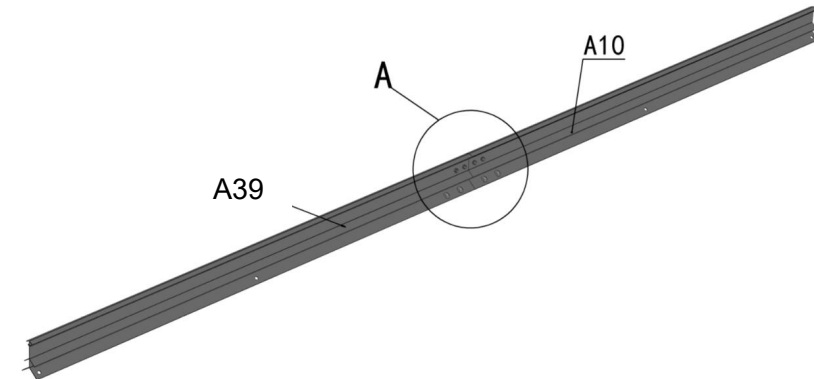
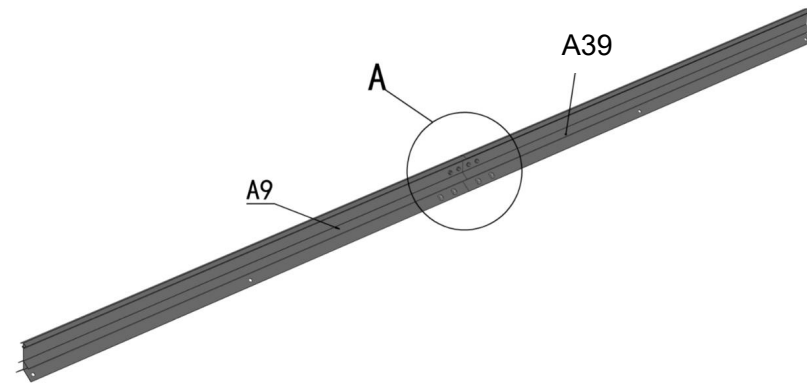

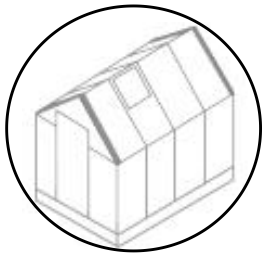

code Kod		Qty Ilość
F4		24
F5		24
A9		1
A10		1
C5		2
C3		2
A39		1

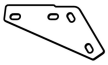





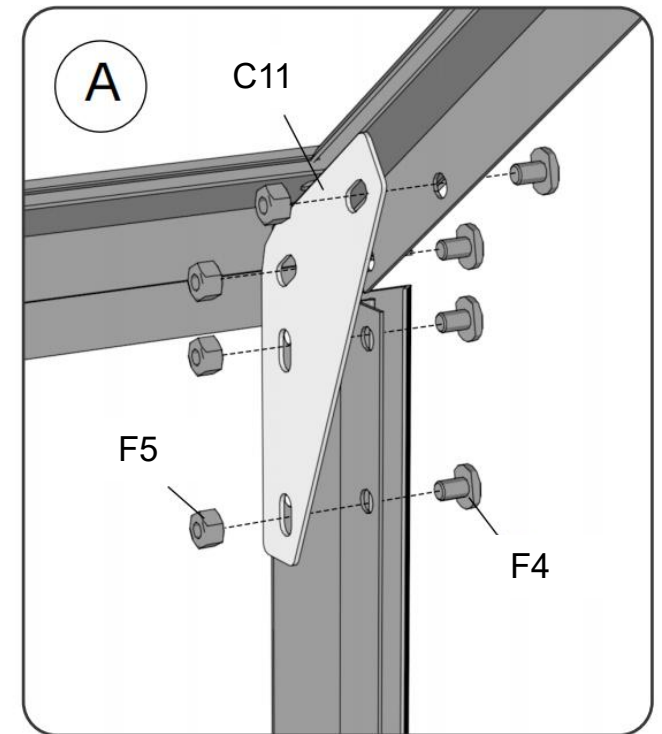
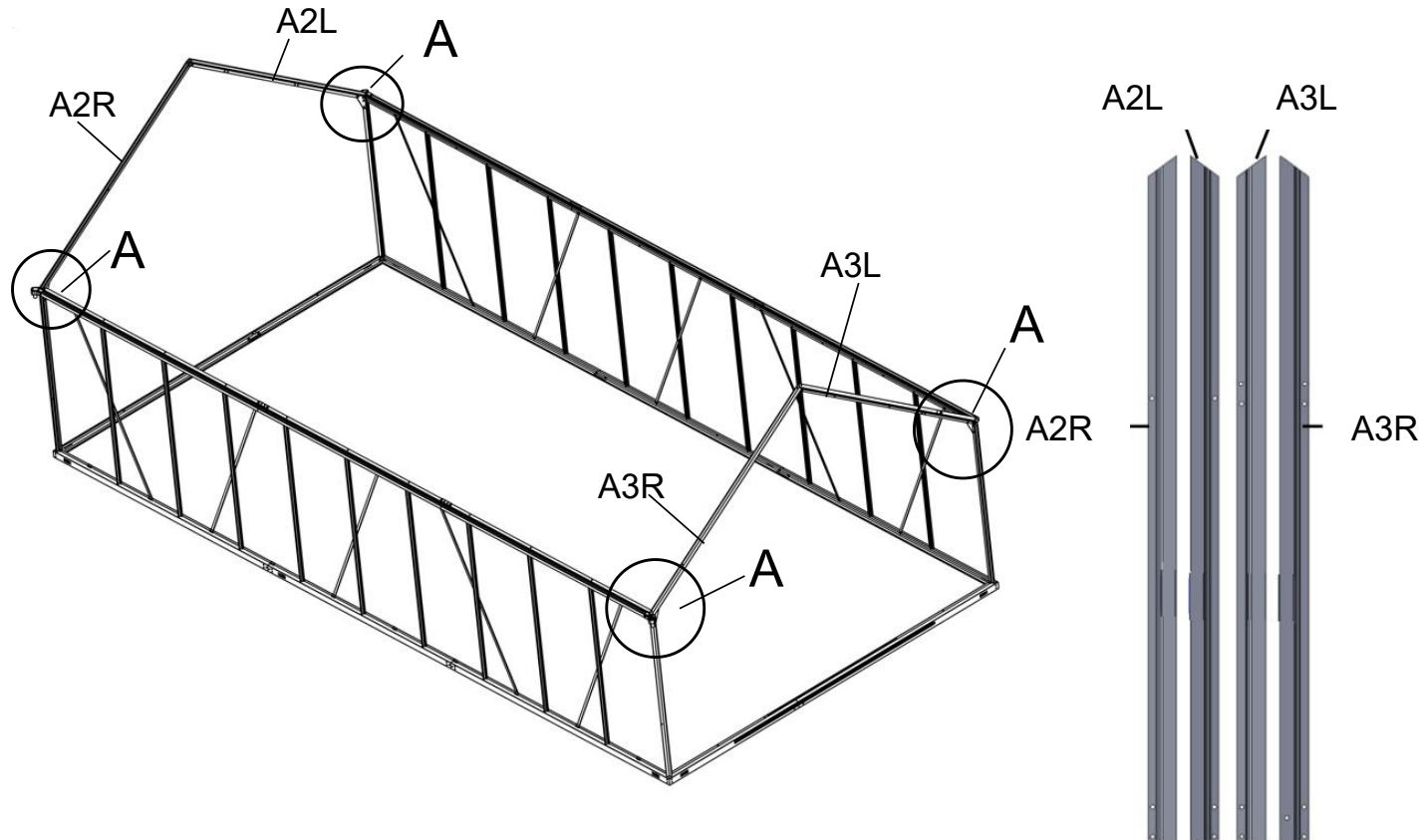

code Kod		Qty Ilość
F4		16
F5		16
C11		4

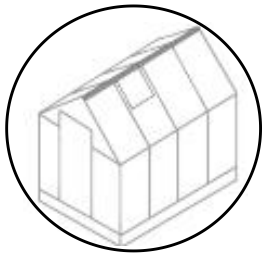
code Kod		Qty Ilość
A2L		1
A2R		1
A3L		1
A3R		1





code Kod		Qty Ilość
F4		4
F5		4
C8		2

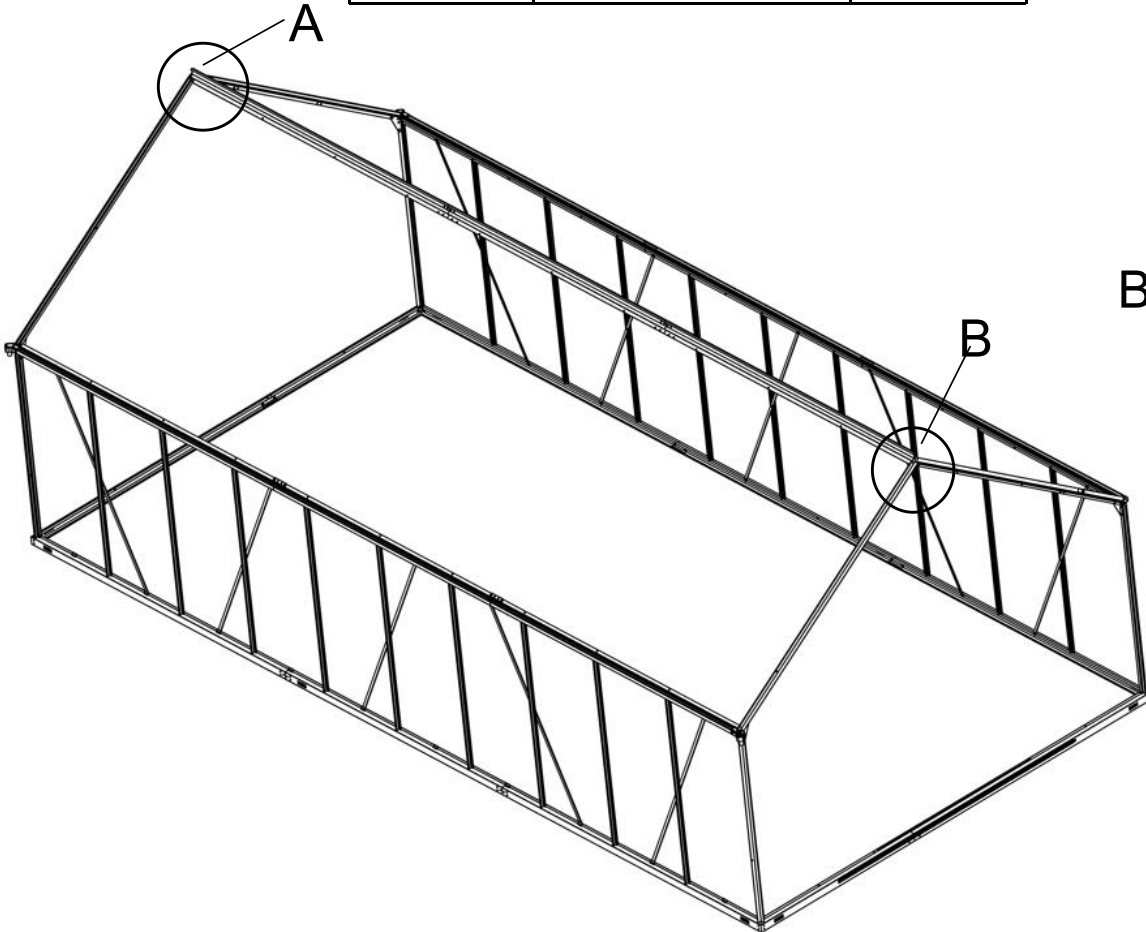

A

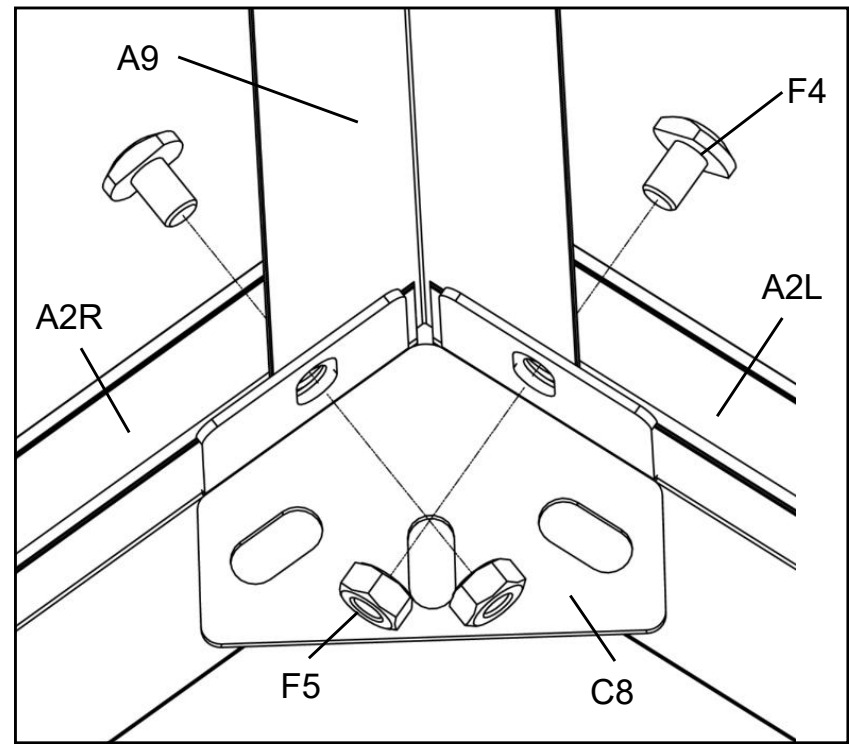

B

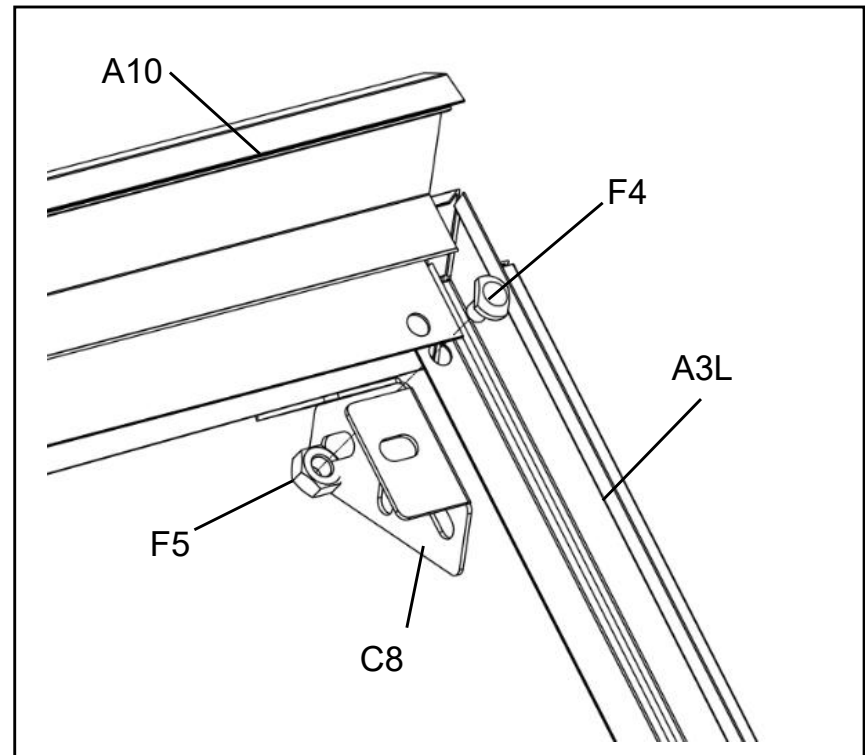

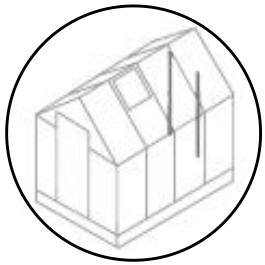

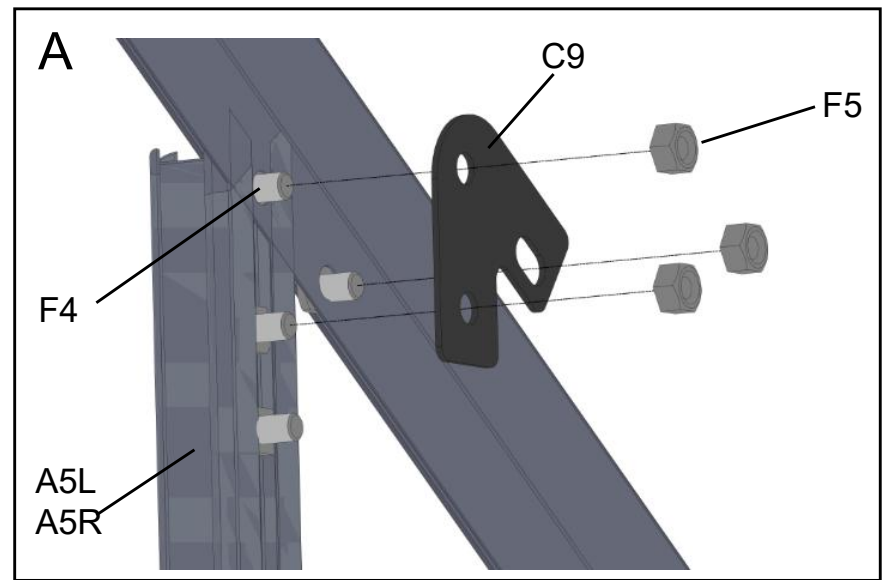

code Kod		Qty Ilość
F4		22
F5		16
A5L		1
A5R		1
A34L		1
A34R		1



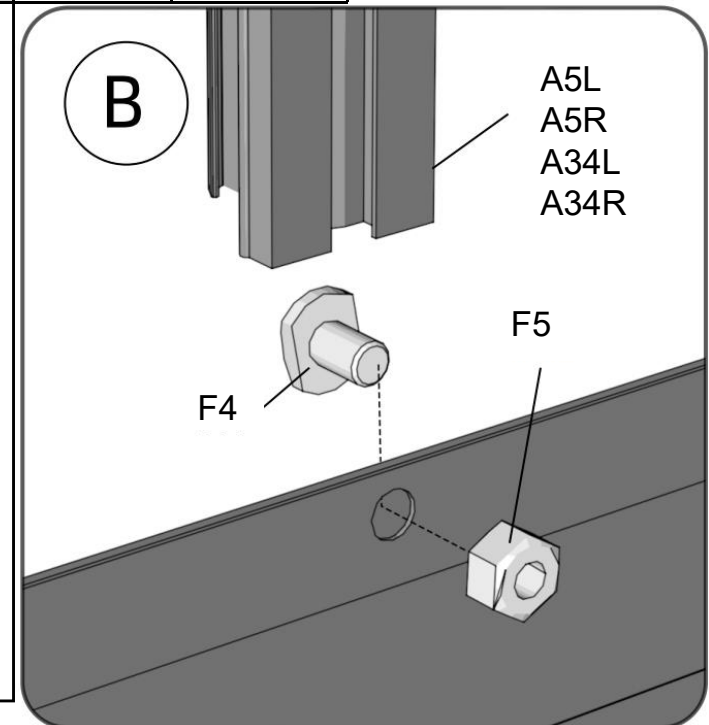
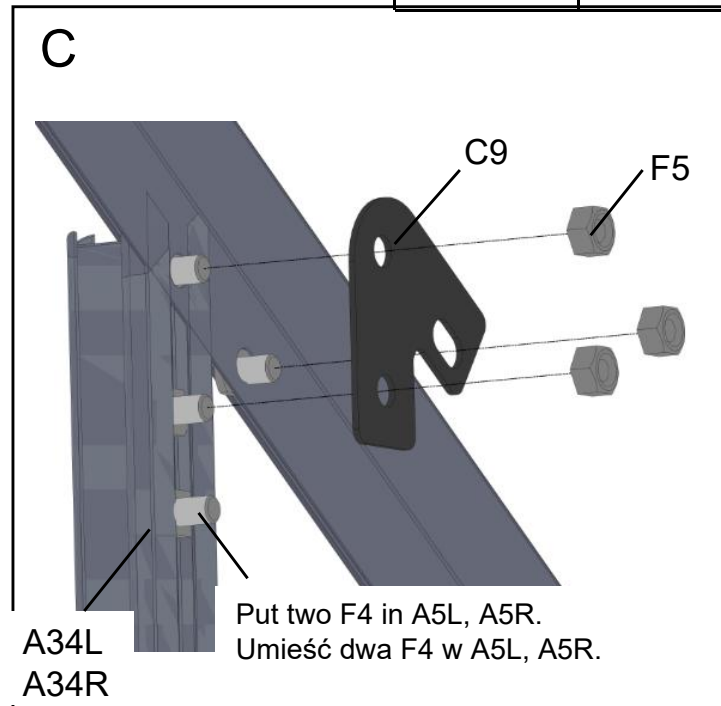
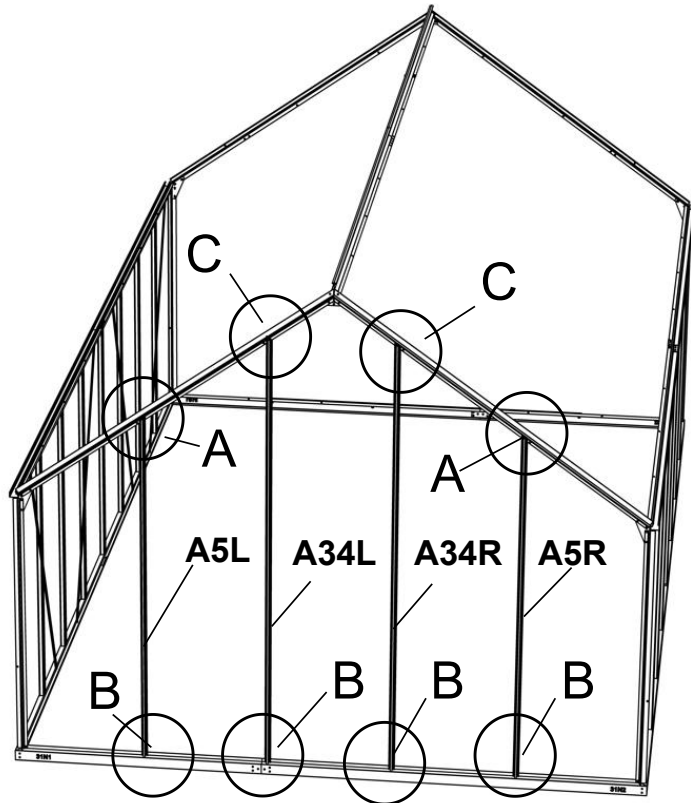

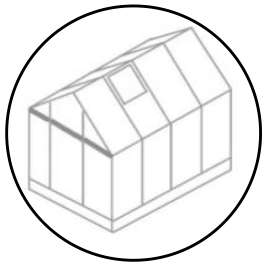
code Kod		Qty Ilość
C9		4









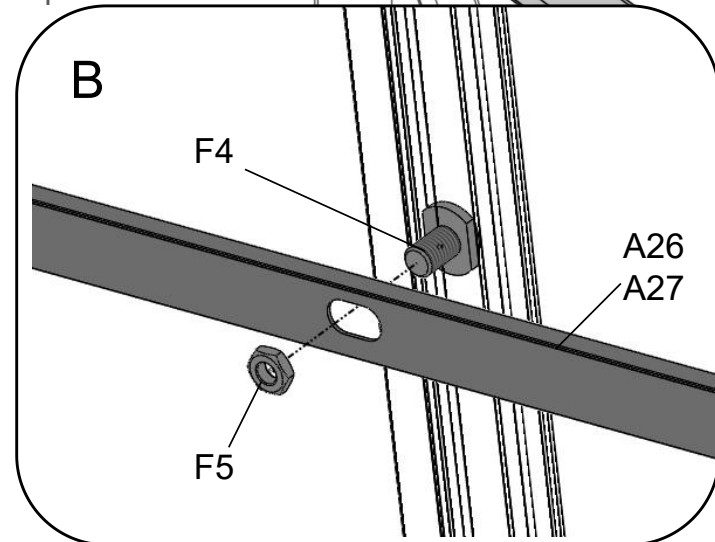
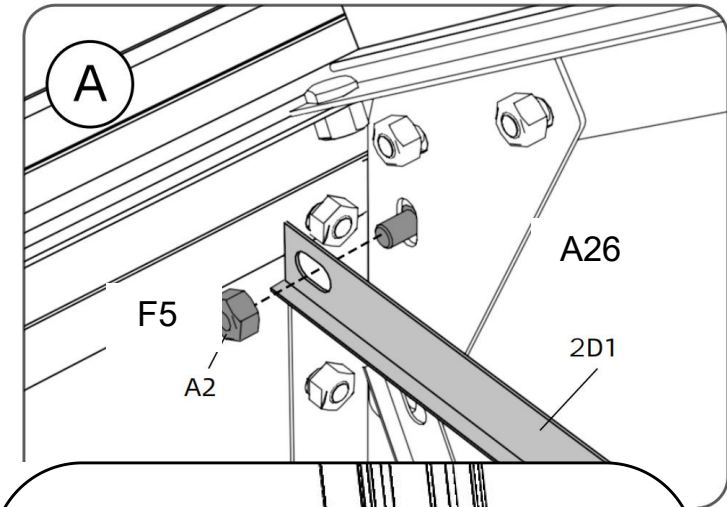
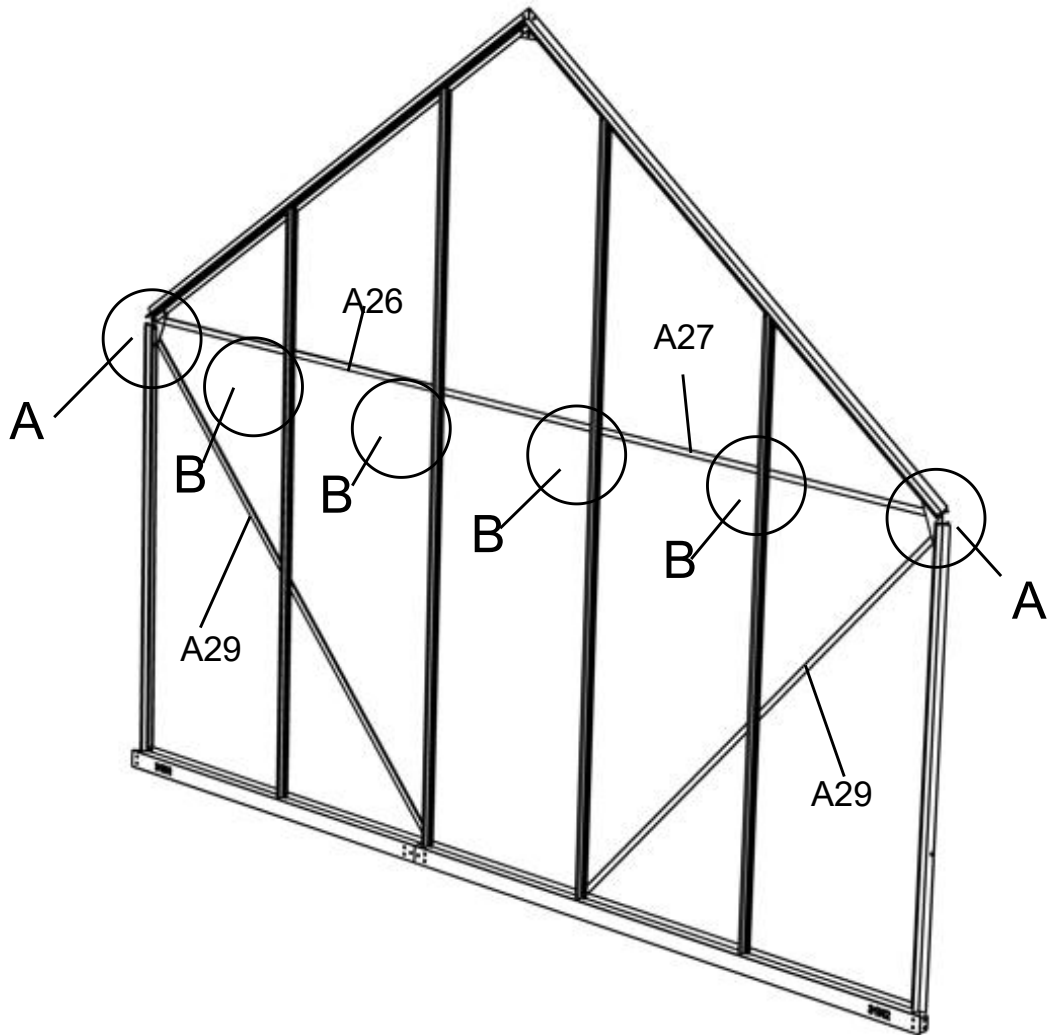

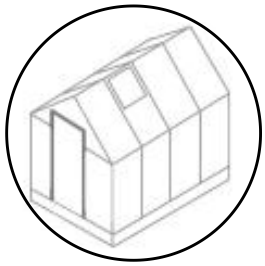
code Kod		Qty Ilość
F5		4
A29		2

code Kod		Qty Ilość
A26		1
A27		1







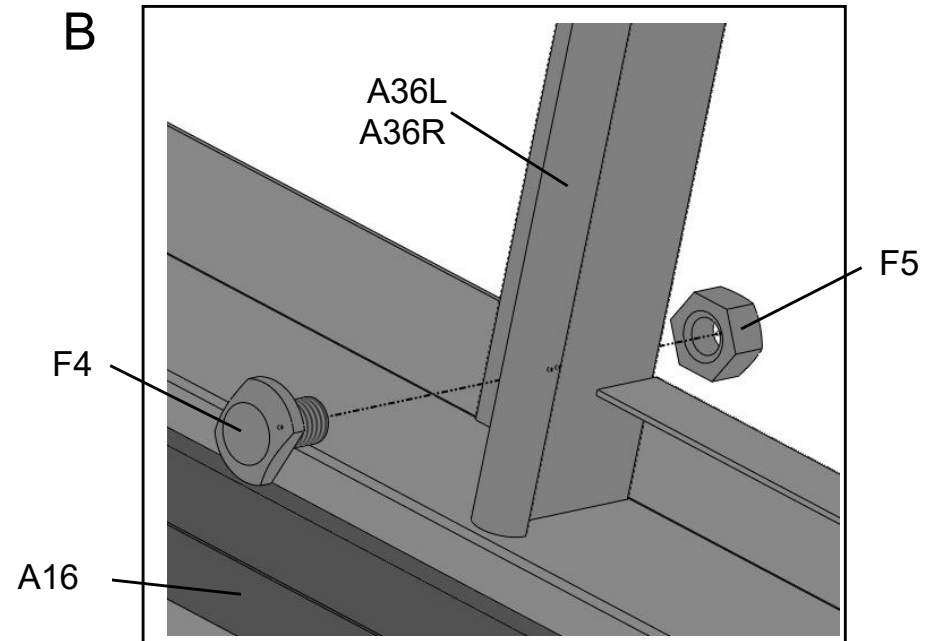
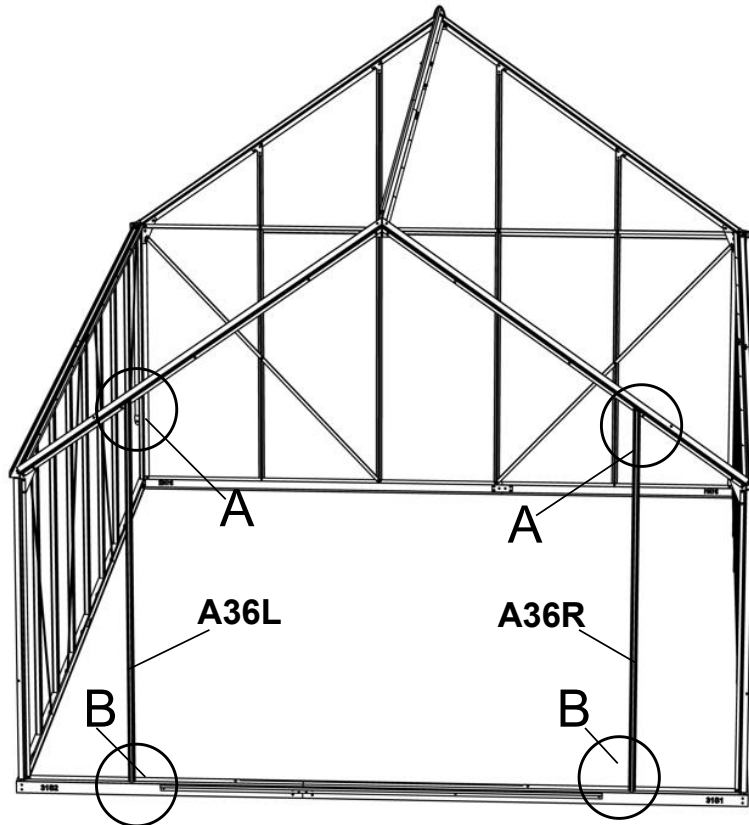
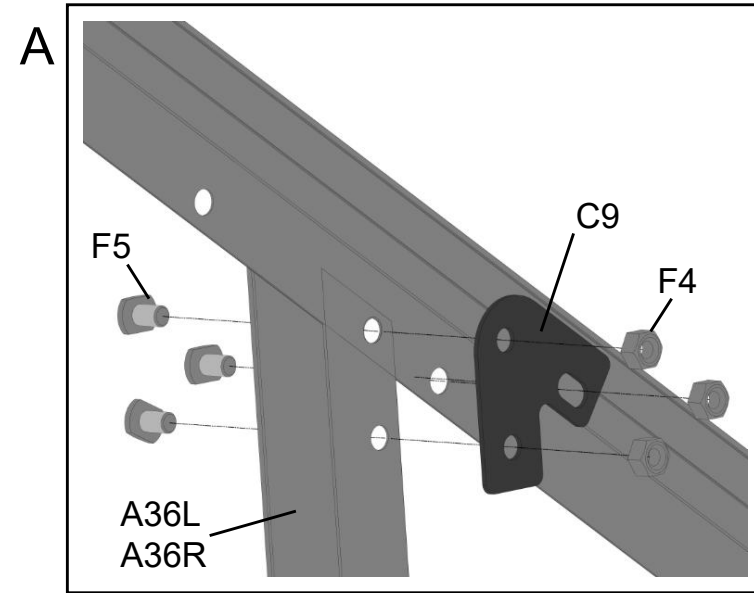

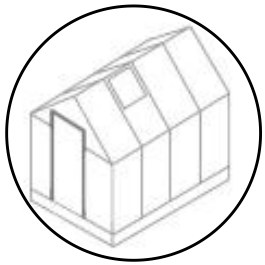
code Kod		Qty Ilość
F4		8
F5		8
A36L		1
A36R		1
C9		2



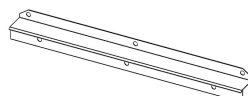

code Kod		Qty Ilość
F4		12
F5		12
A15L		1

code Kod		Qty Ilość
A12		1
C10		2
A15R		1

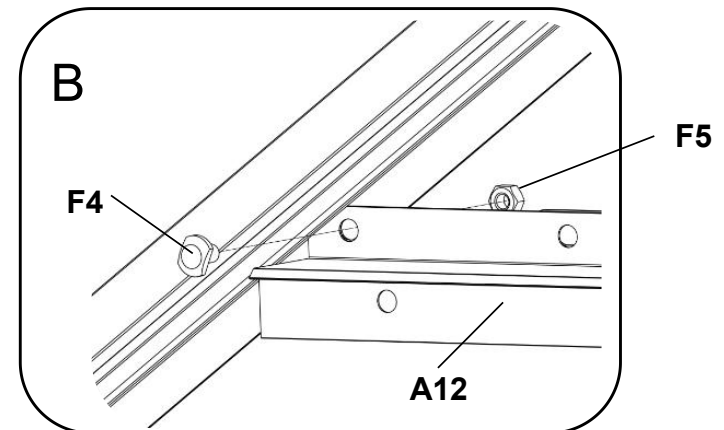
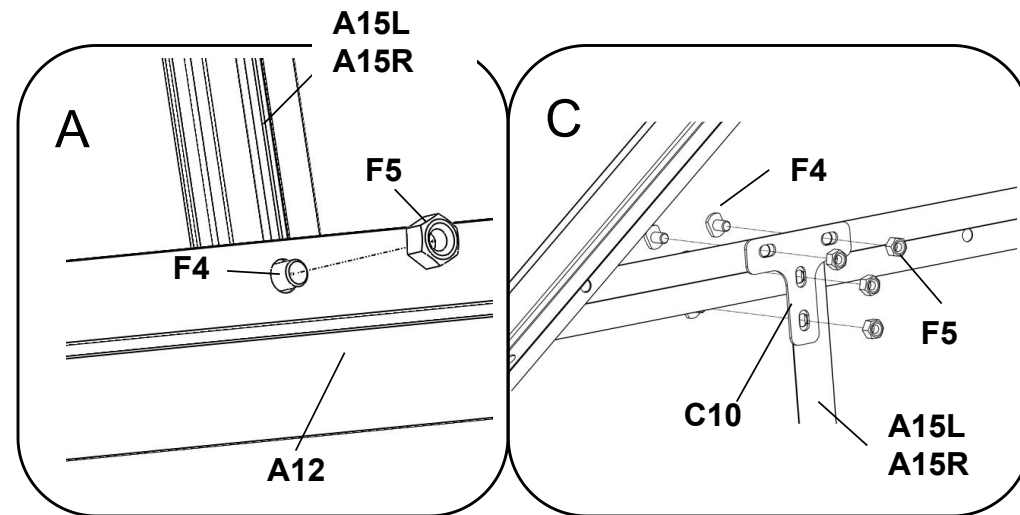
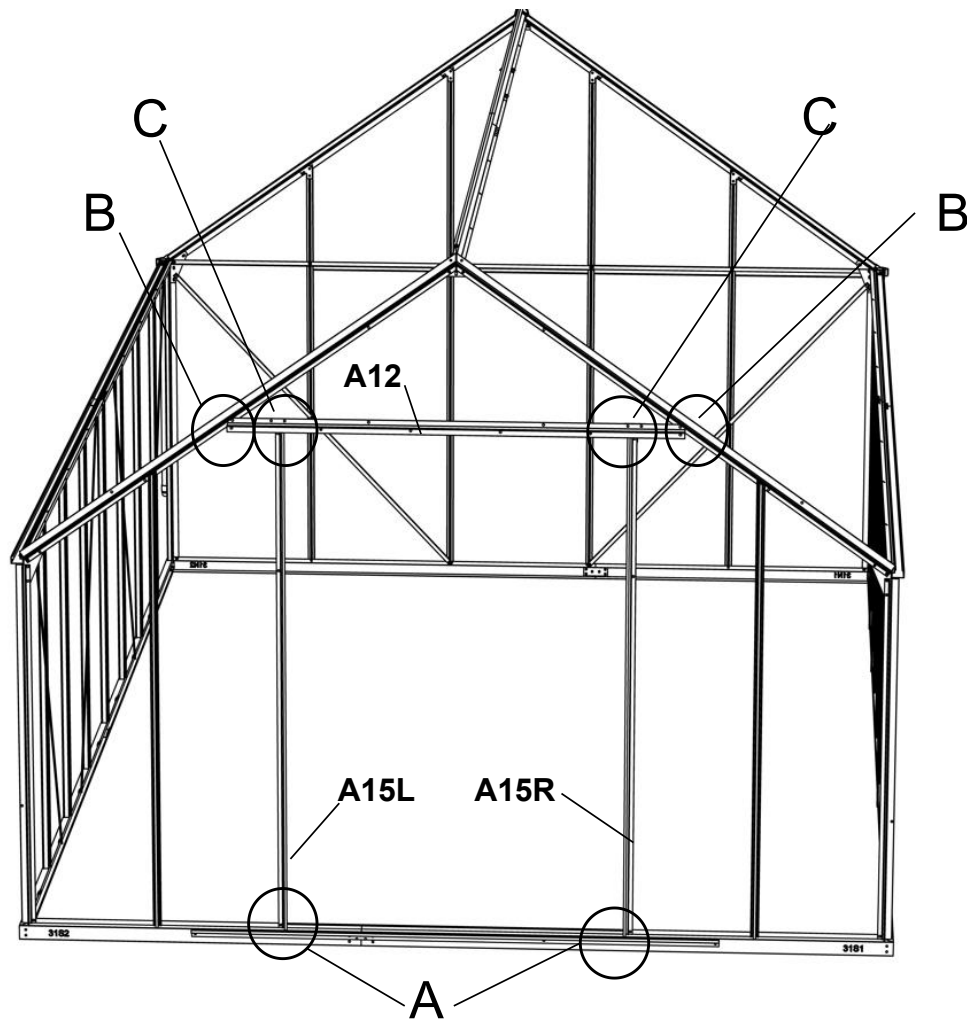

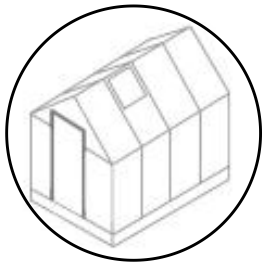

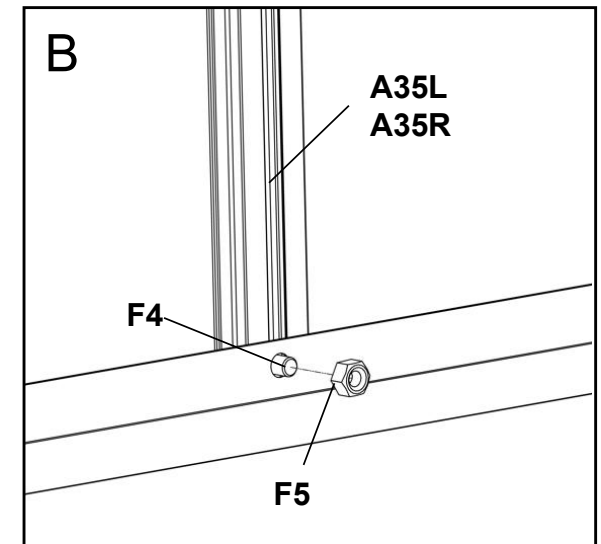
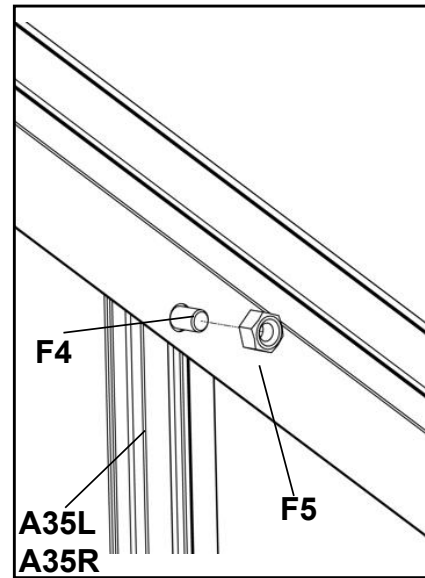
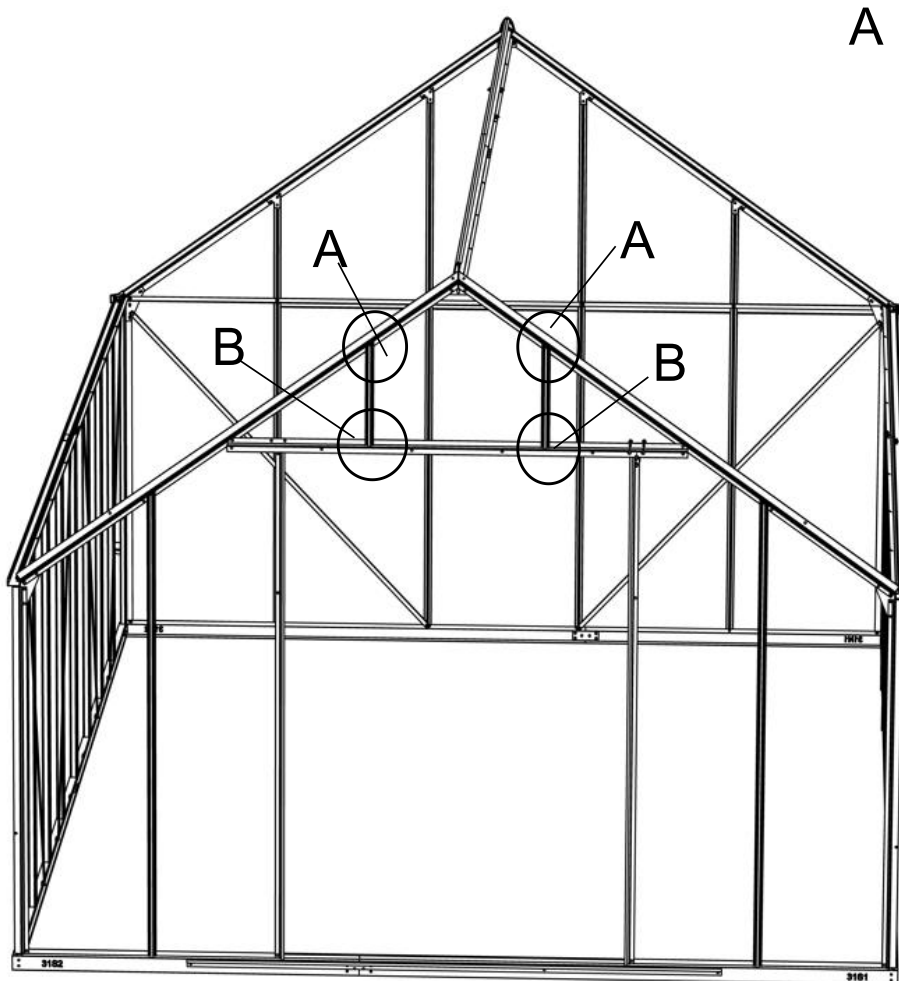

code Kod		Qty Ilość
F4		4
F5		4
A35L		1

code Kod		Qty Ilość
A35R		1

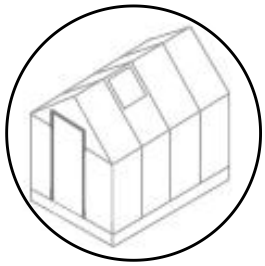



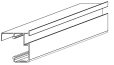

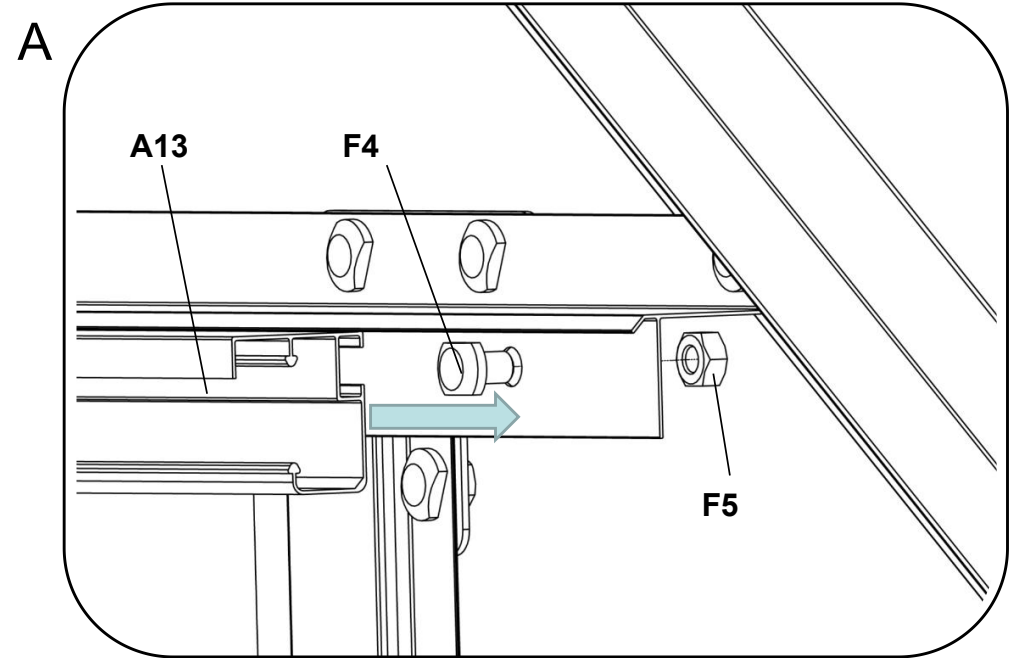
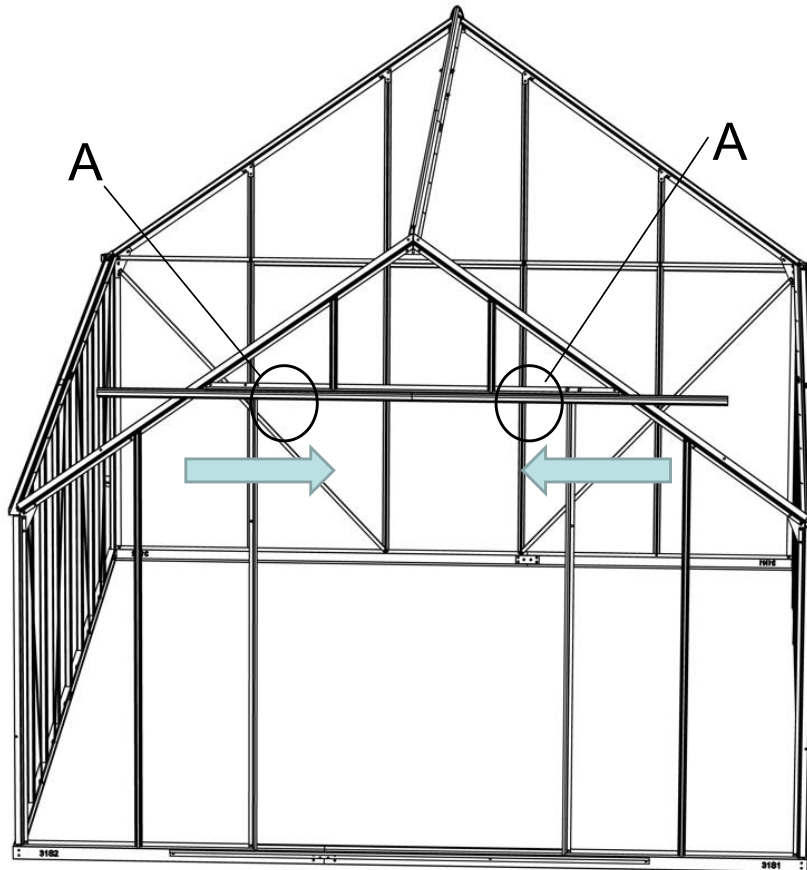

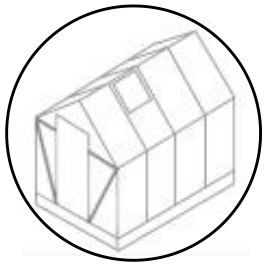
code Kod		Qty Ilość
F4		6
F5		6
A13		2







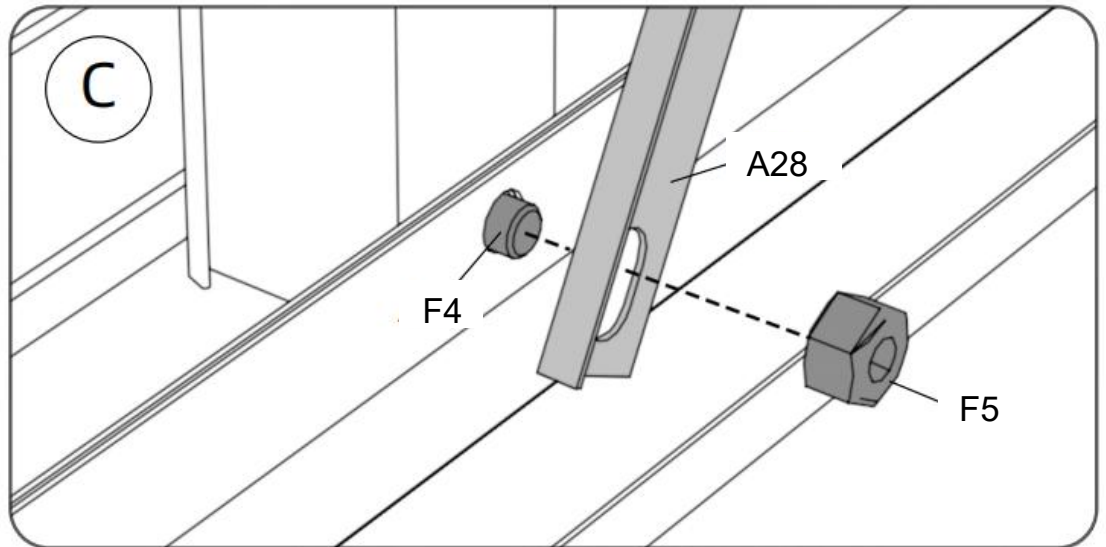
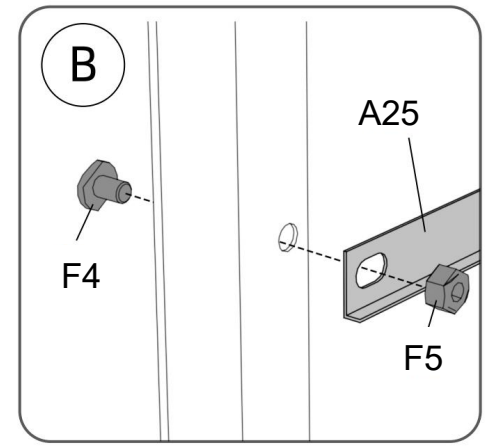
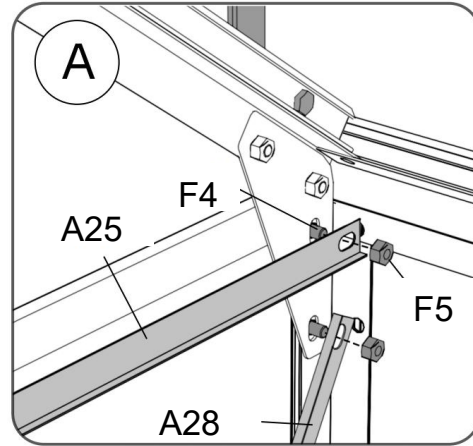
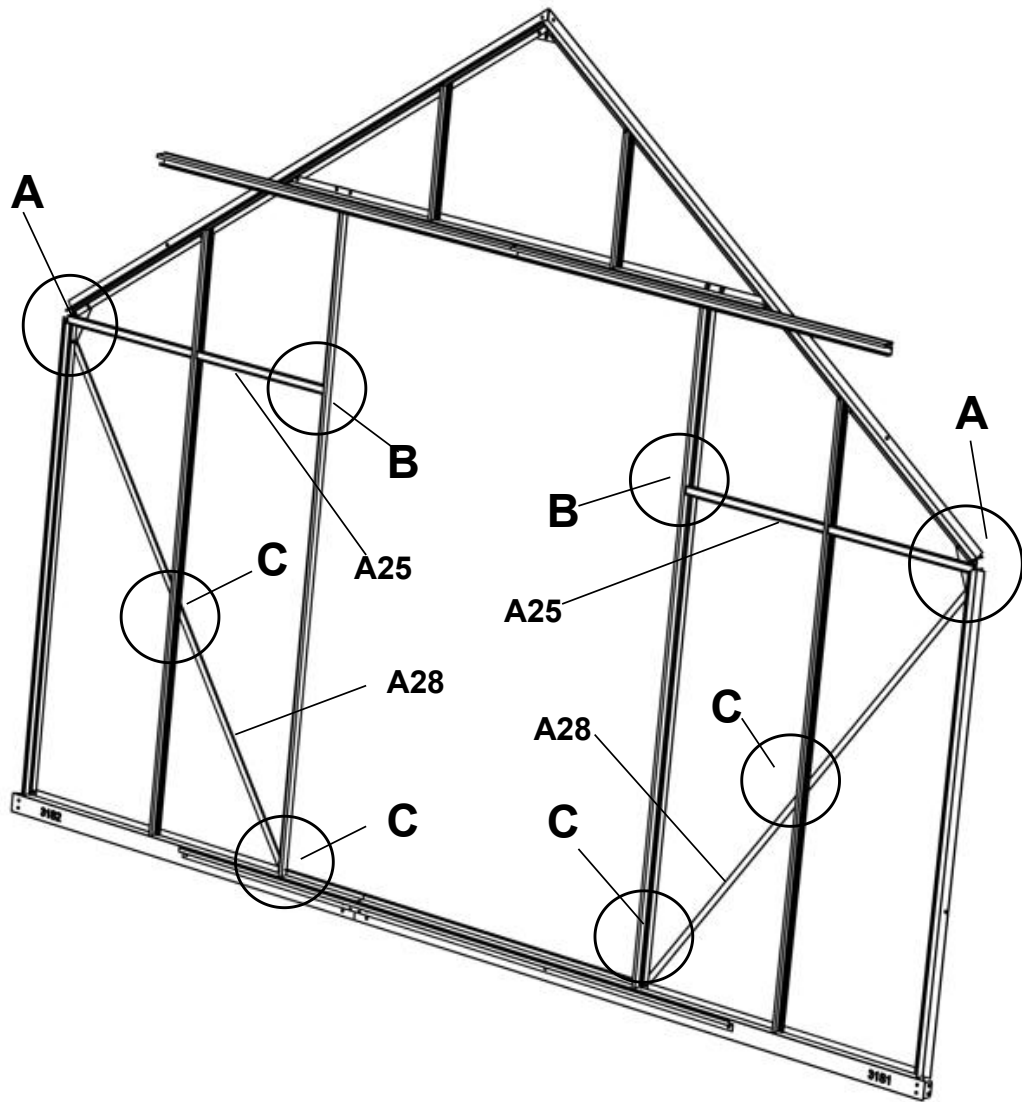

code Kod		Qty Ilość
F4		4
F5		4

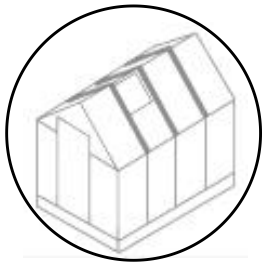
code Kod		Qty Ilość
A25		2
A28		2





code Kod		Qty Ilość
F4		63
F5		36

code Kod		Qty Ilość
A6		18

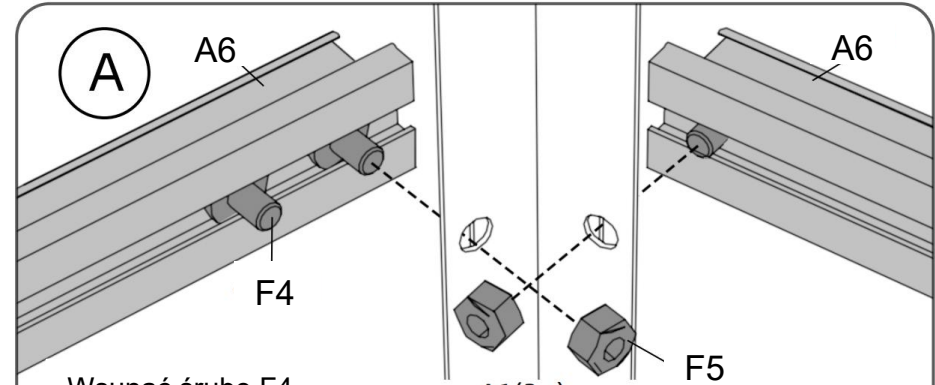
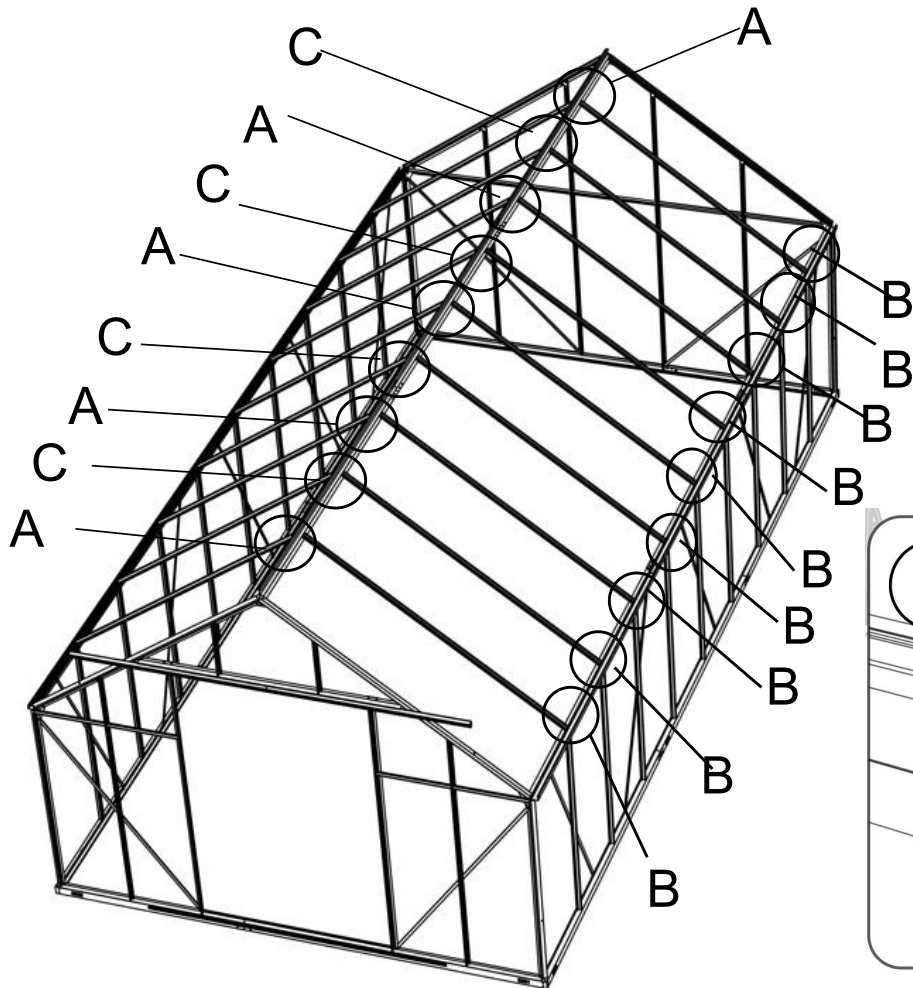



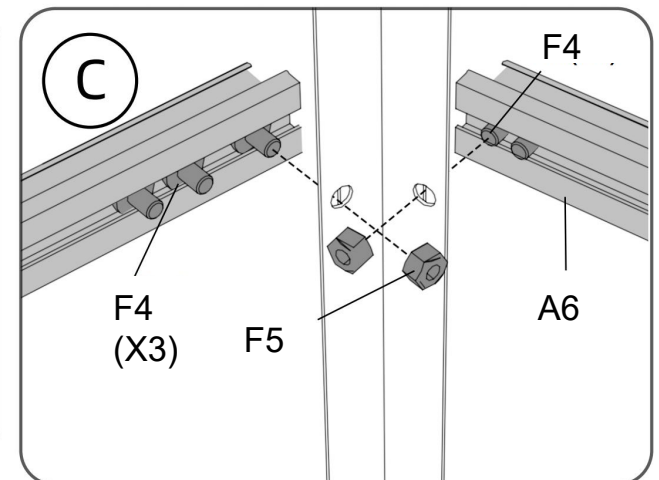
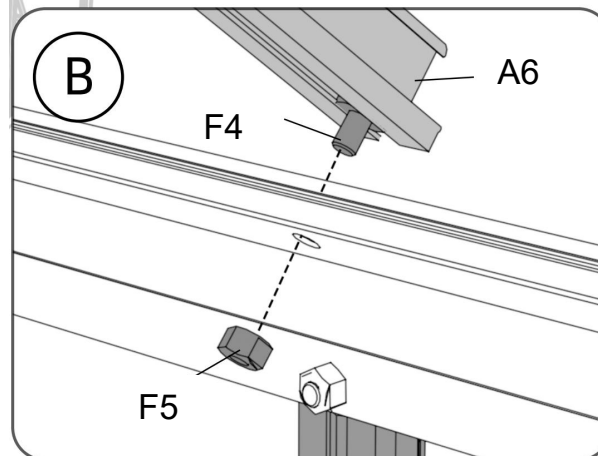



Wsunać śrubę F4 (x2) przed zamocowaniem profilu A6

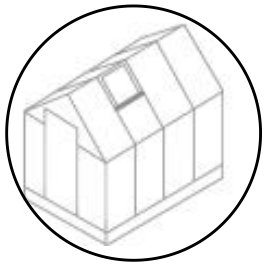

Put three F4 in A6.



Wsunać śrubę F4 (x3) przed zamocowaniem profilu A6. 33



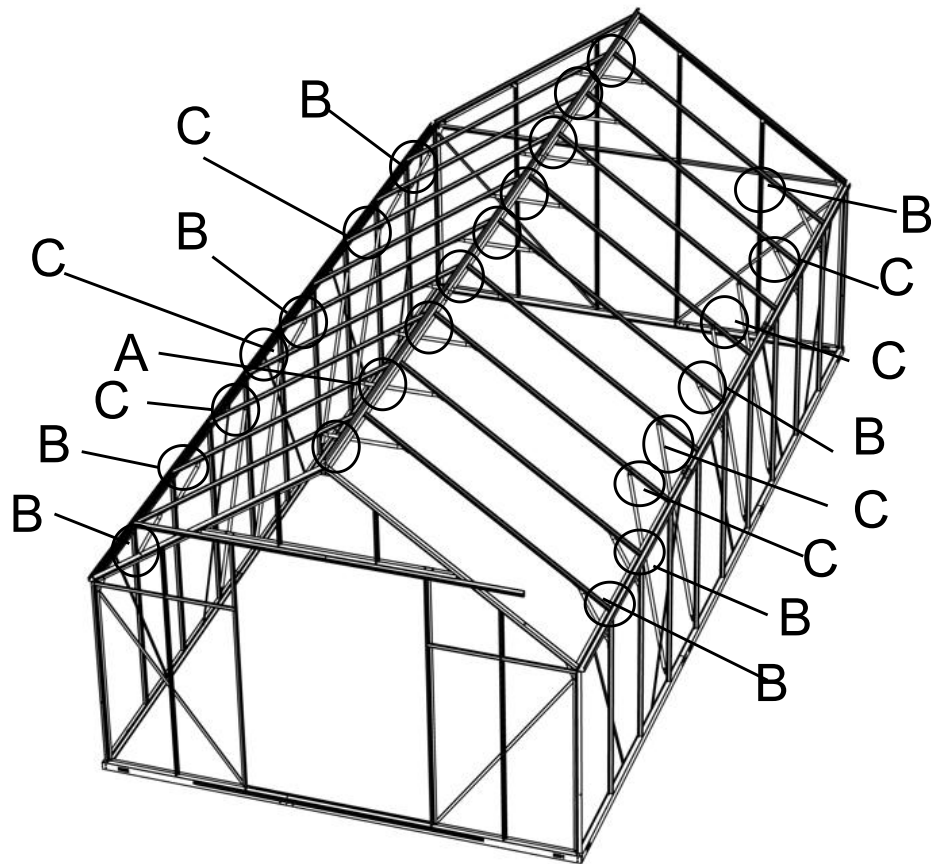
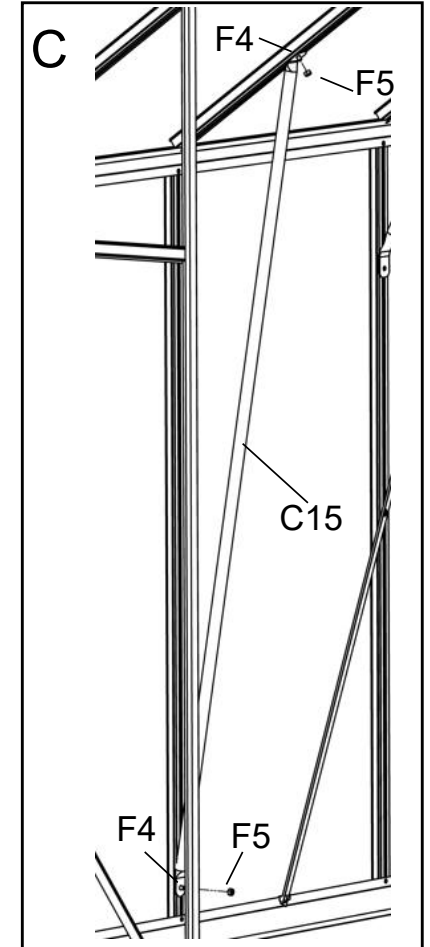
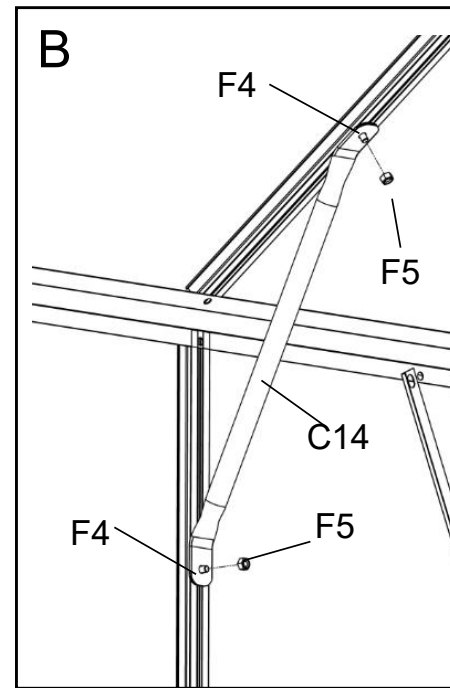
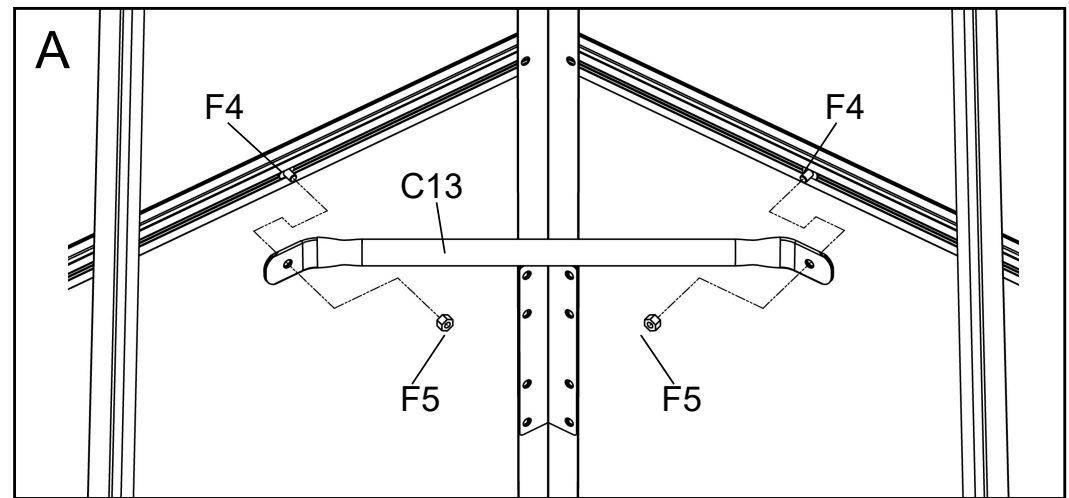

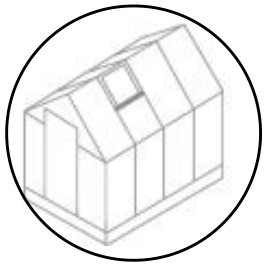
code Kod		Qty Ilość
F4		54
F5		54
C13		9
C14		10
C15		8



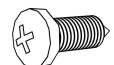



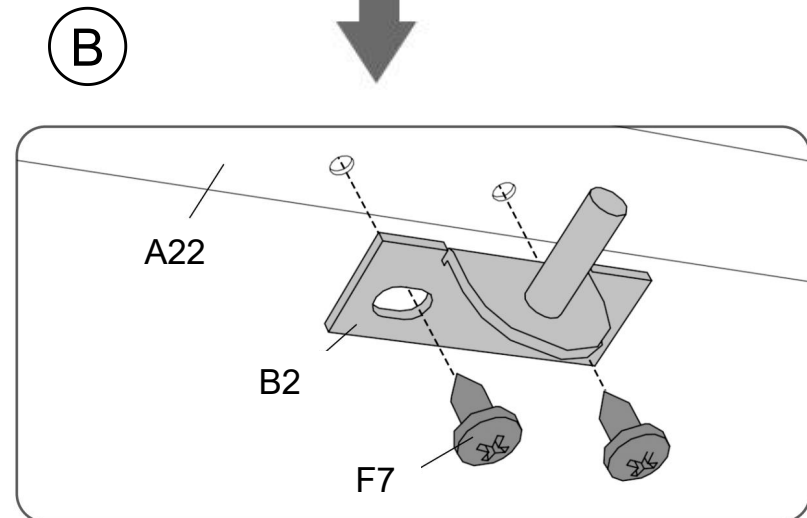
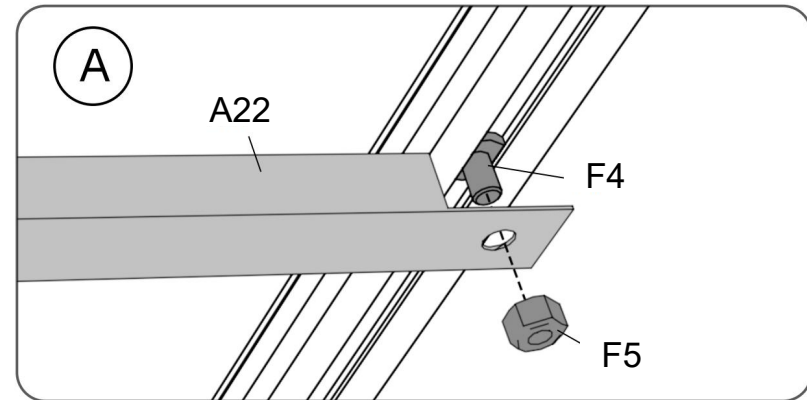
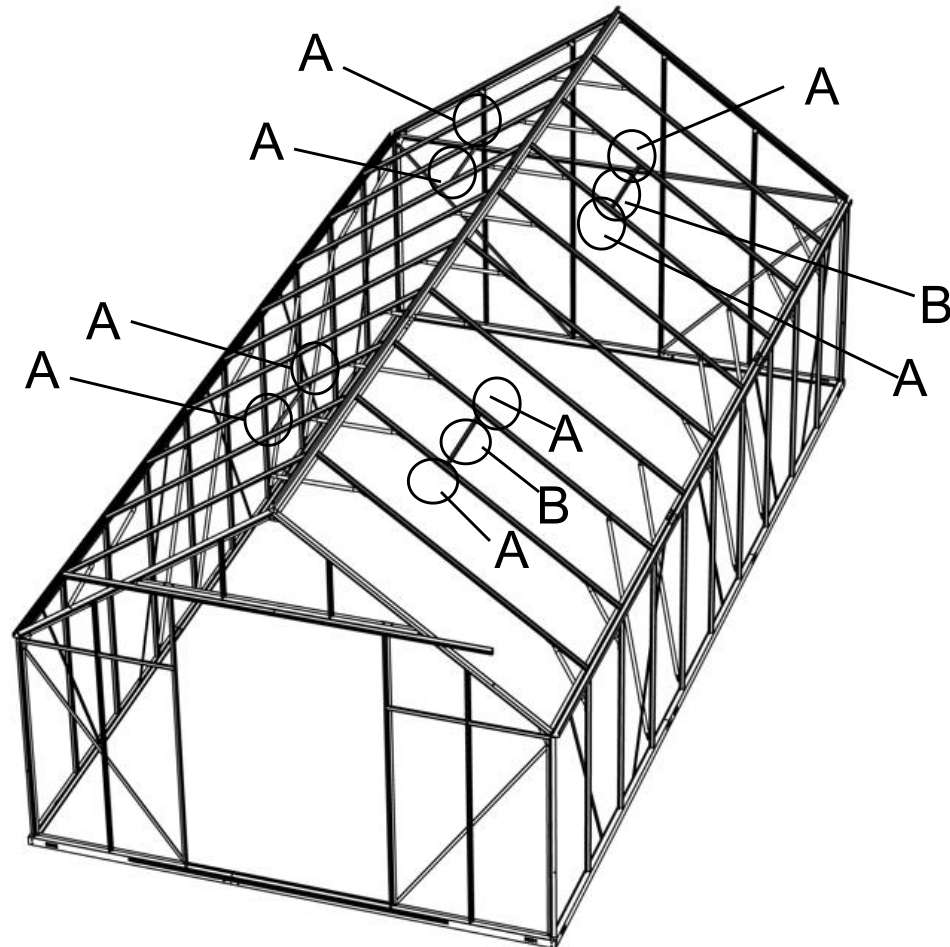

code Kod		Qty Ilość
F4		8
F5		8
F7		16

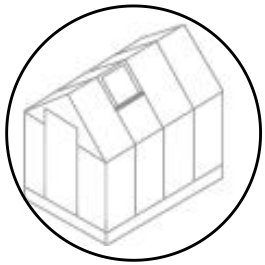
code Kod		Qty Ilość
A22		4
B2		8





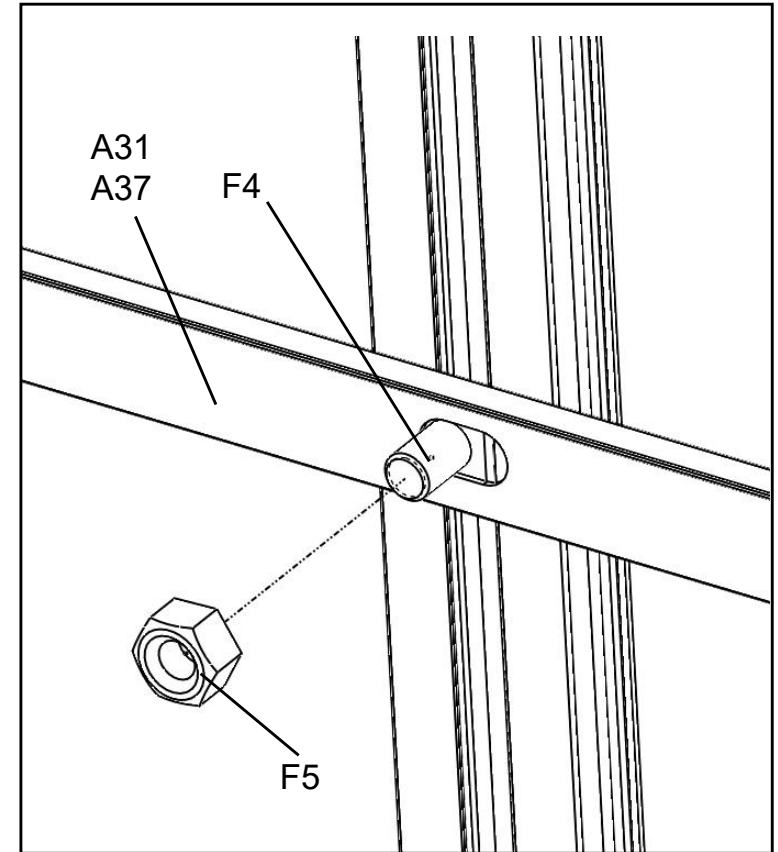
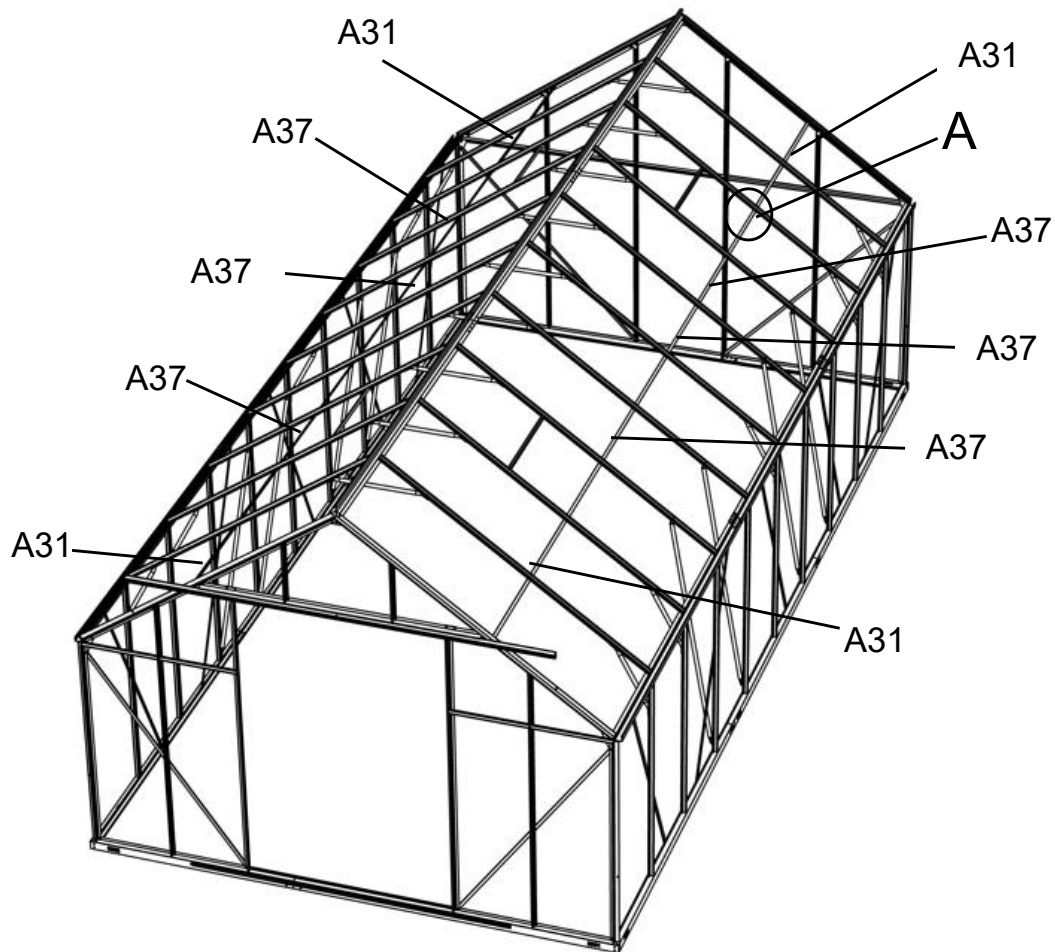

code Kod		Qty Ilość
F4		18
F5		18
A31		4
A37		6

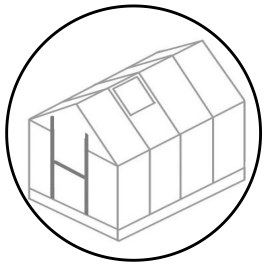





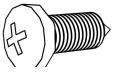

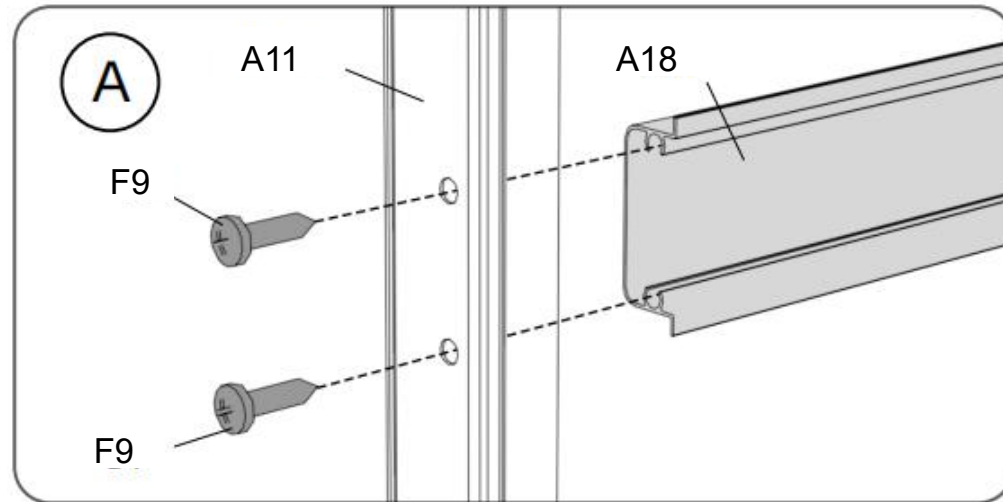
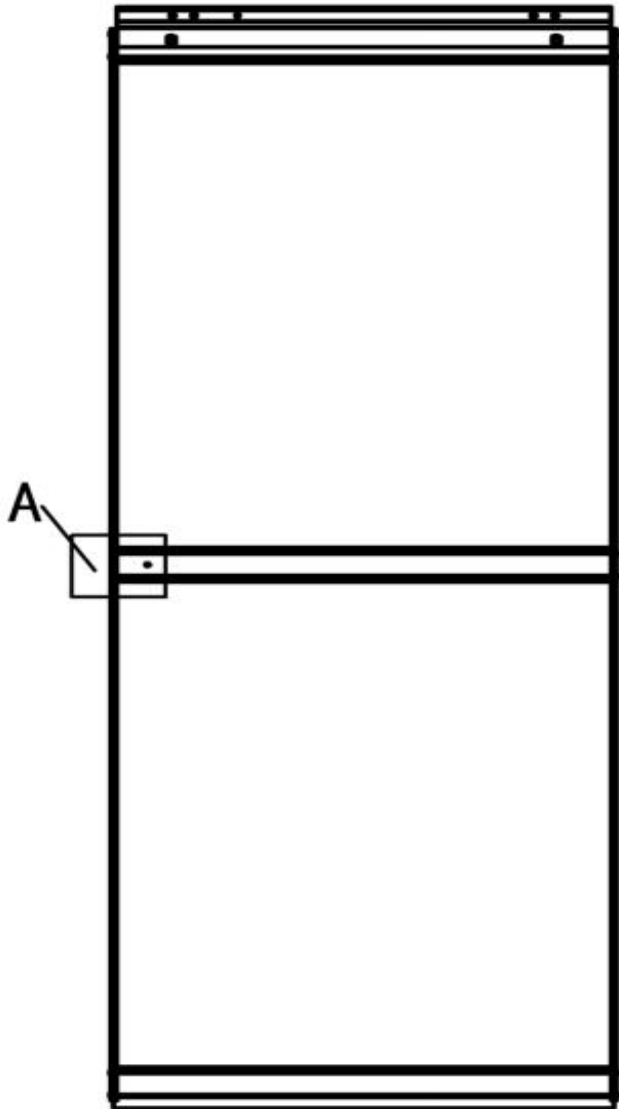

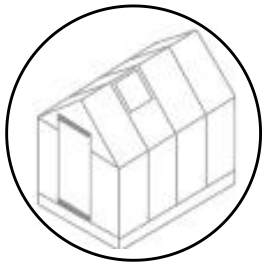
code Kod		Qty Ilość
A11		4

code Kod		Qty Ilość
A18		2
F9		8



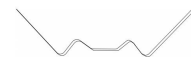

code Kod		Qty Ilość
A17		2
A19		2
F9		16

code Kod		Qty Ilość
B3		48
P12		4

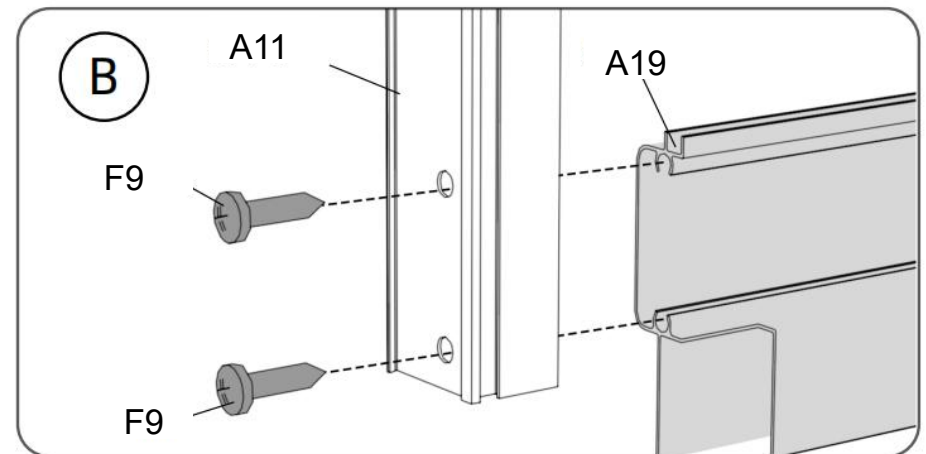
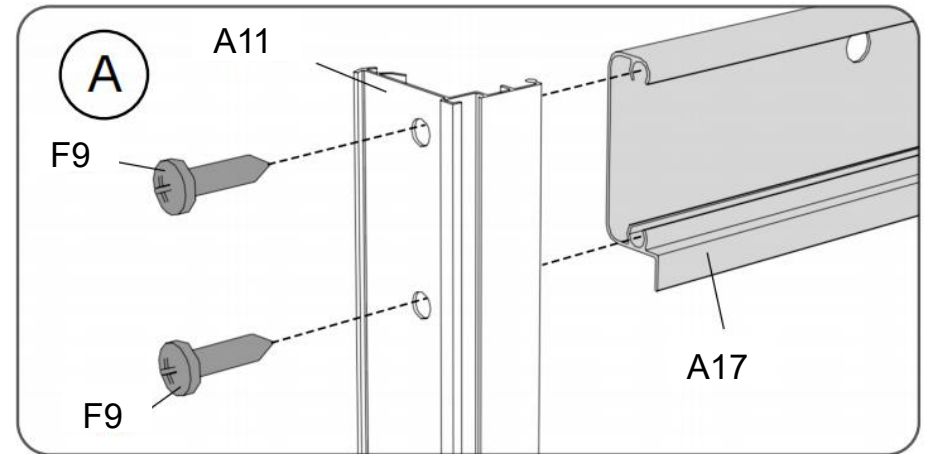
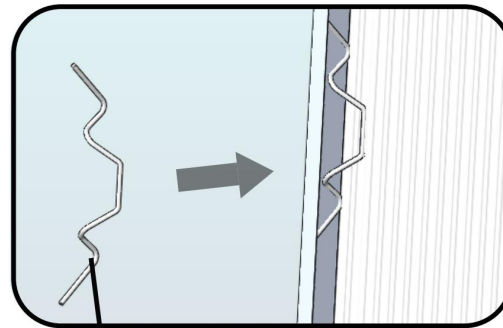
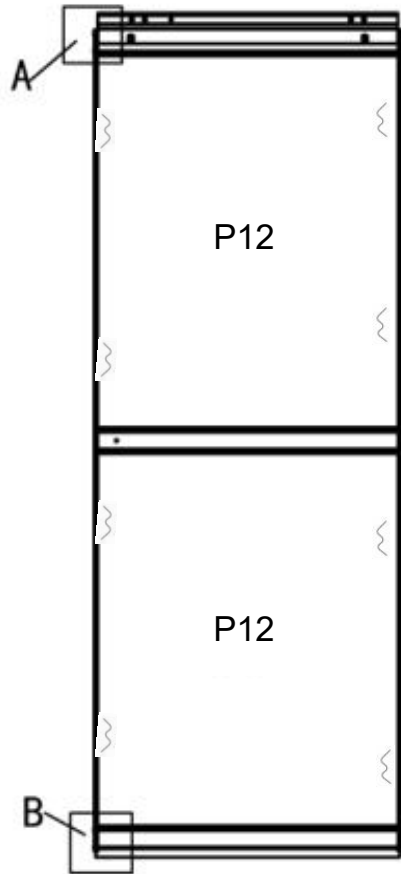

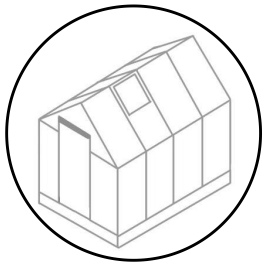

code Kod		Qty Ilość
F4		4
F5		8
A20		1



code Kod		Qty Ilość
S2		4
F3		8
F10		8
F8		8

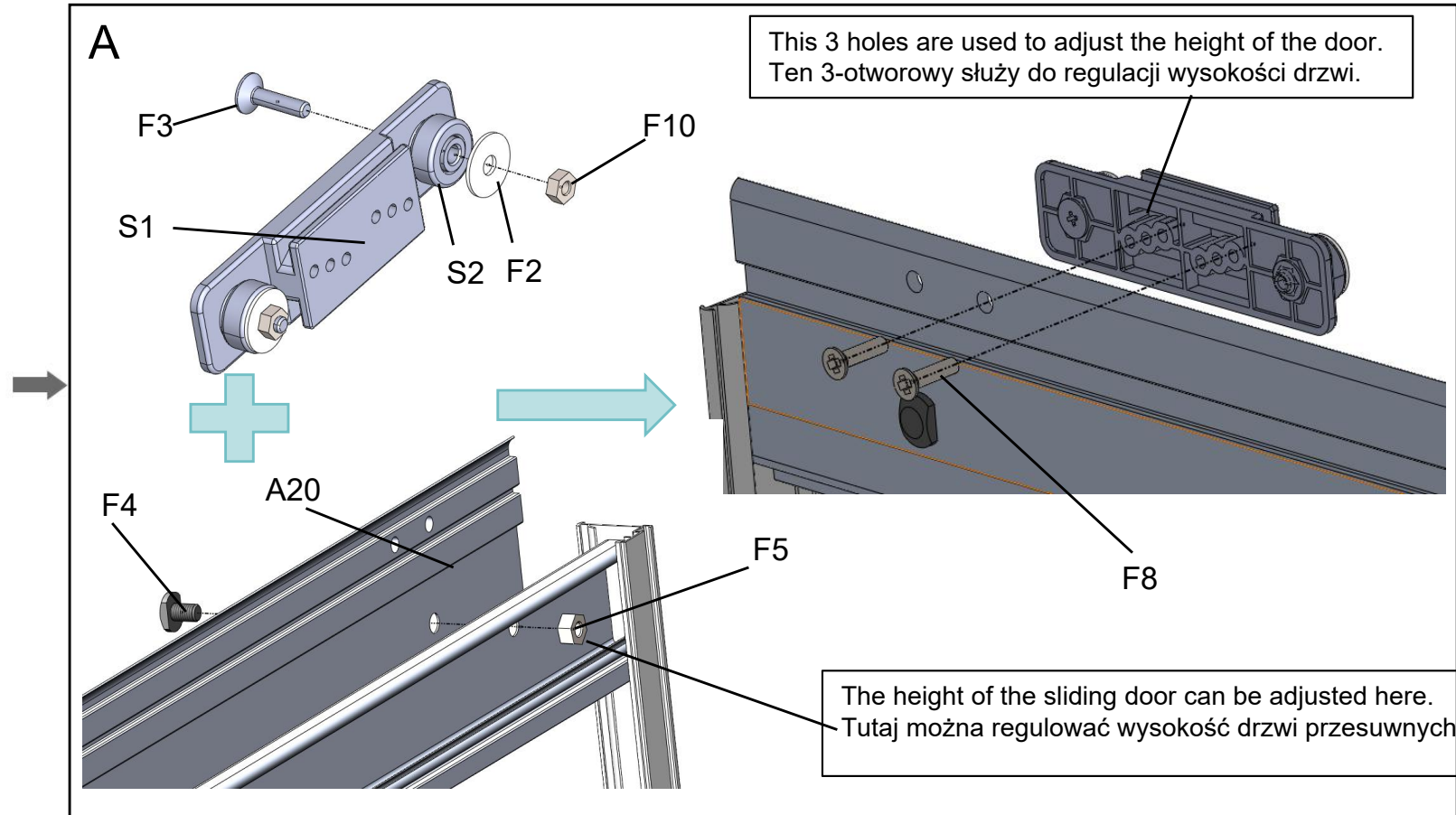
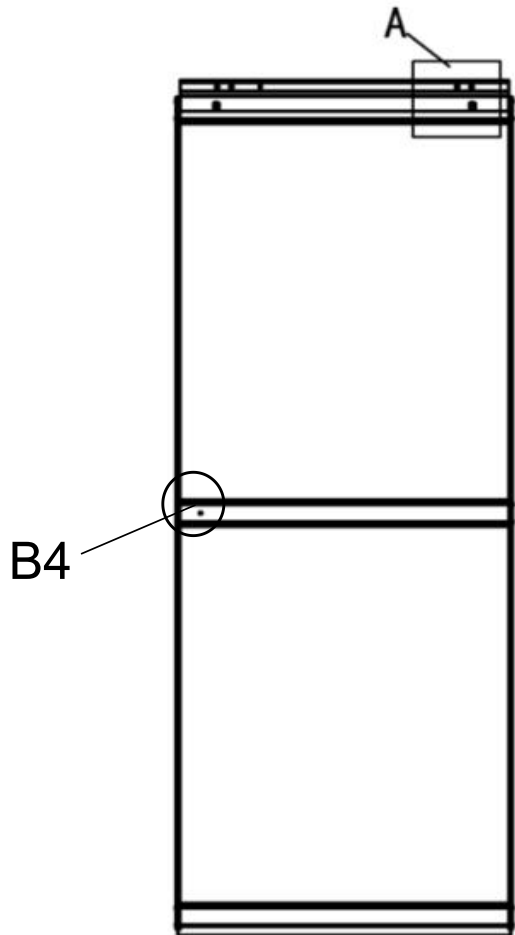

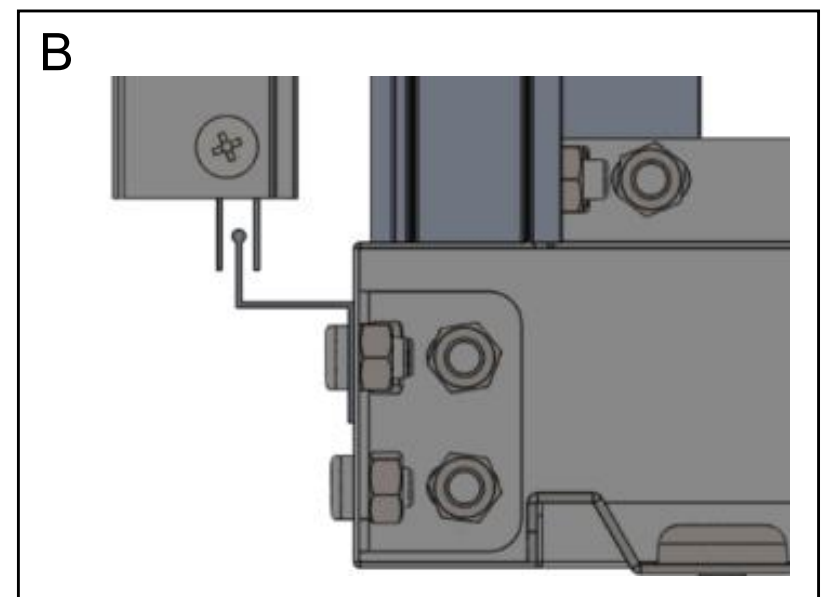
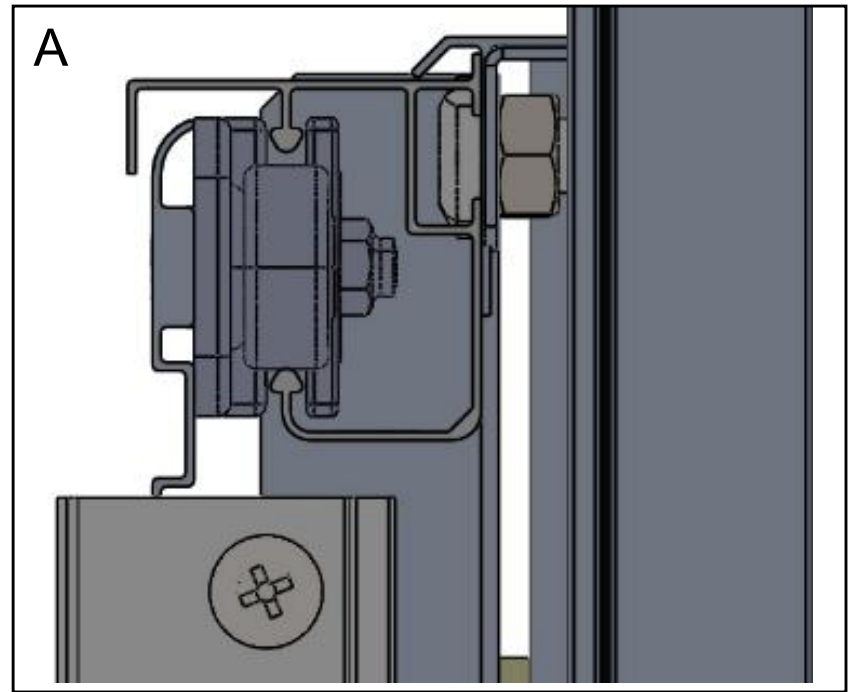
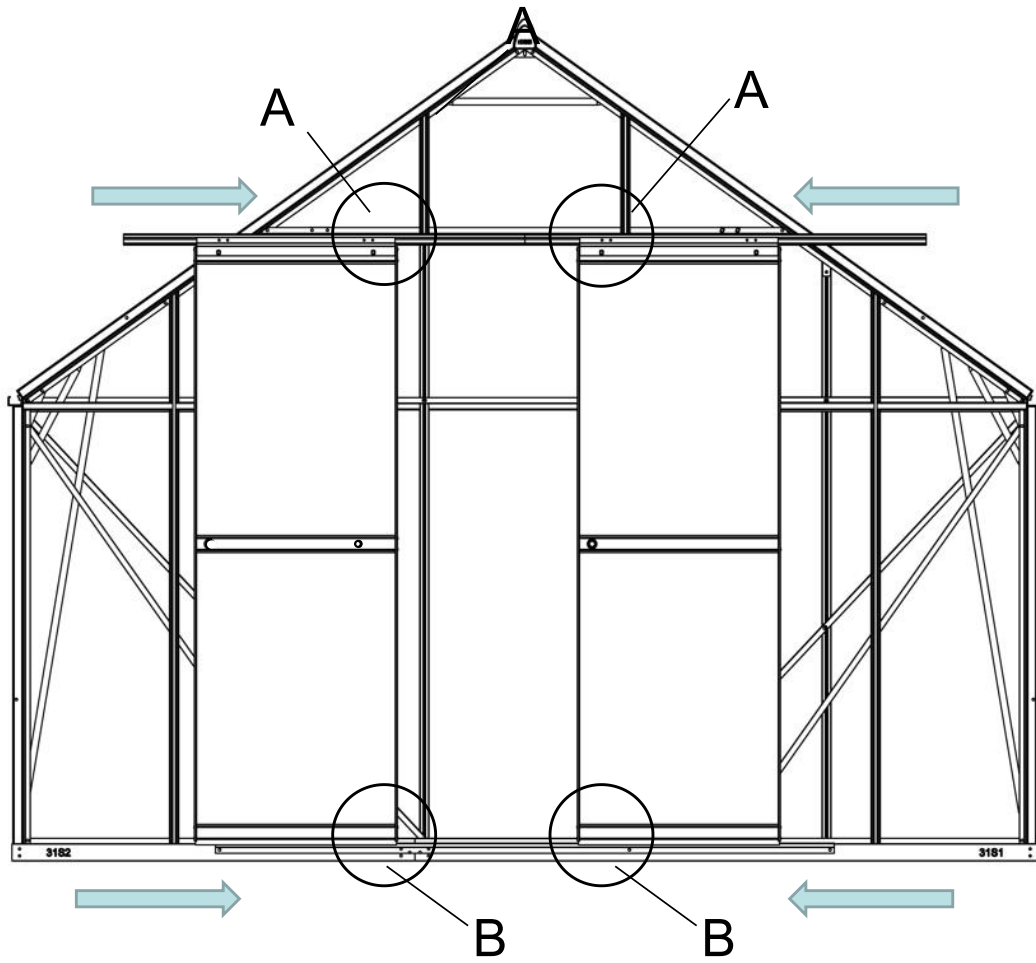
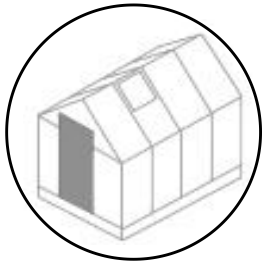
code Kod		Qty Ilość
S1		4
F2		8
B4		2

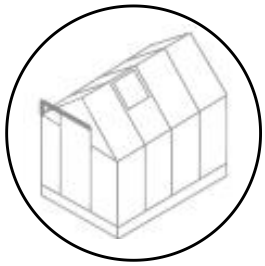









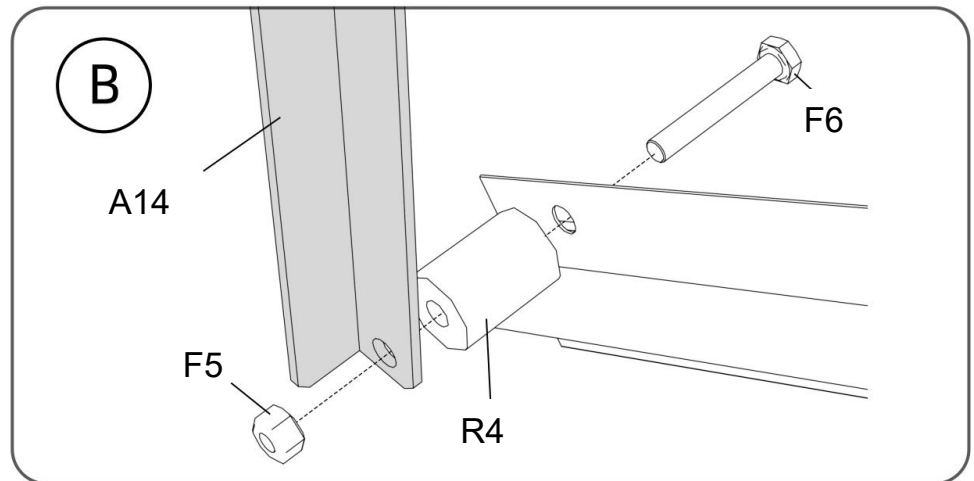
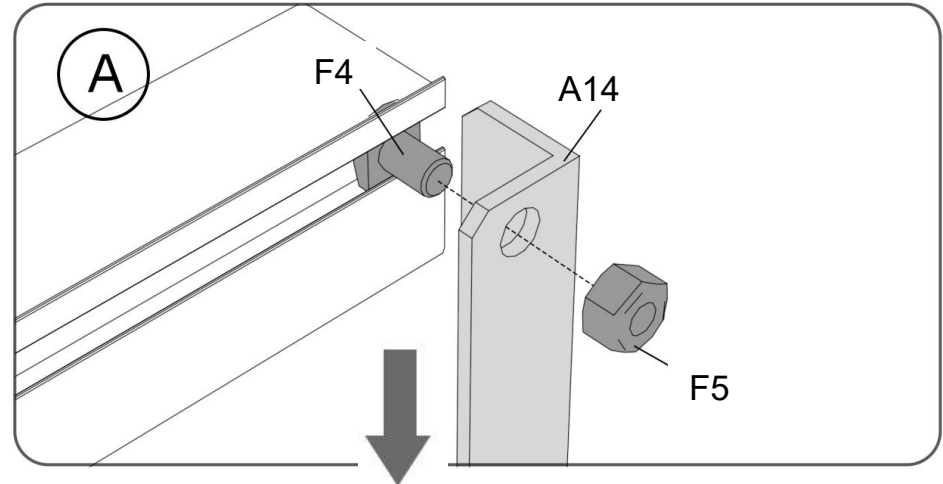
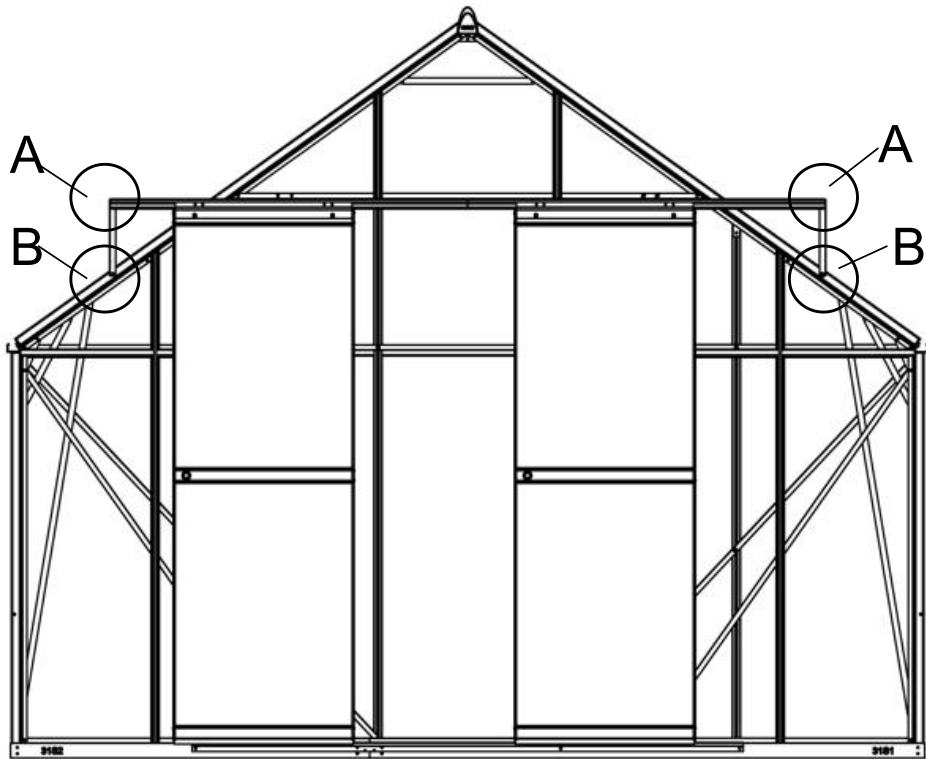

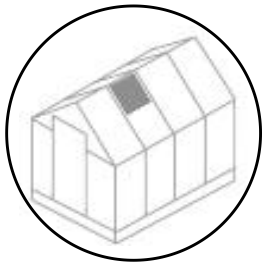
code Kod		Qty Ilość
F4		2
F5		4
F6		2



code Kod		Qty Ilość
R4		2
A14		2





code Kod		Qty Ilość
A23		4
A21L		4
A24		4

code Kod		Qty Ilość
A21R		4
F7		8
B1		8

code Kod		Qty Ilość
P13		4
F5		16
F4		16

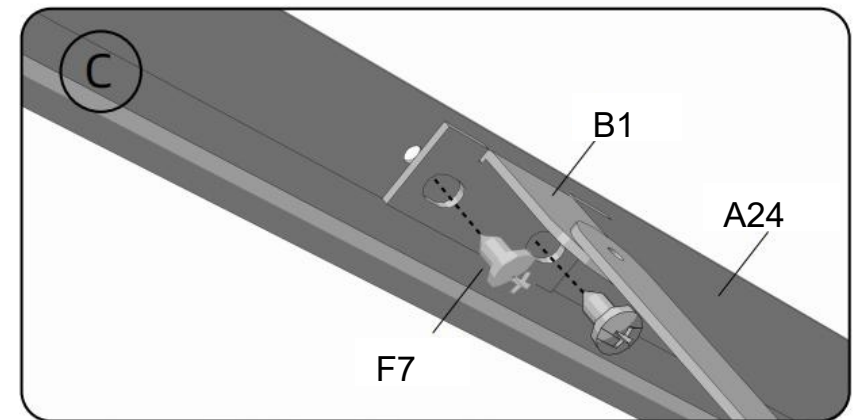
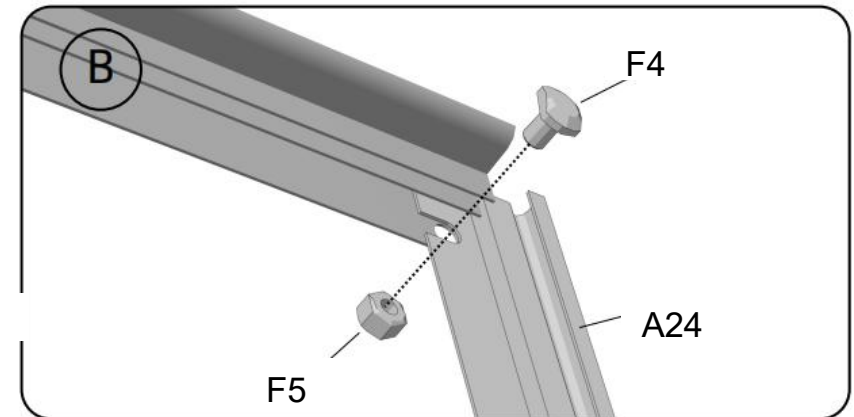
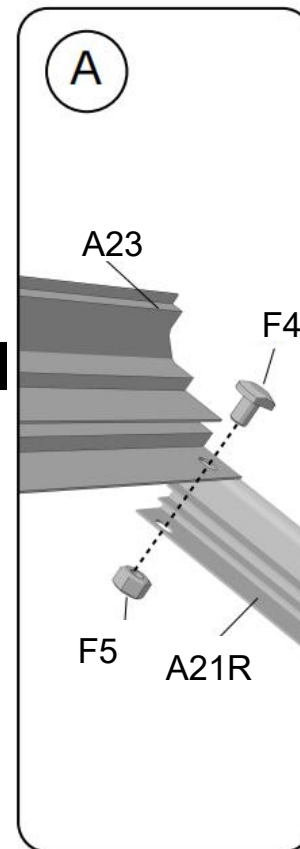
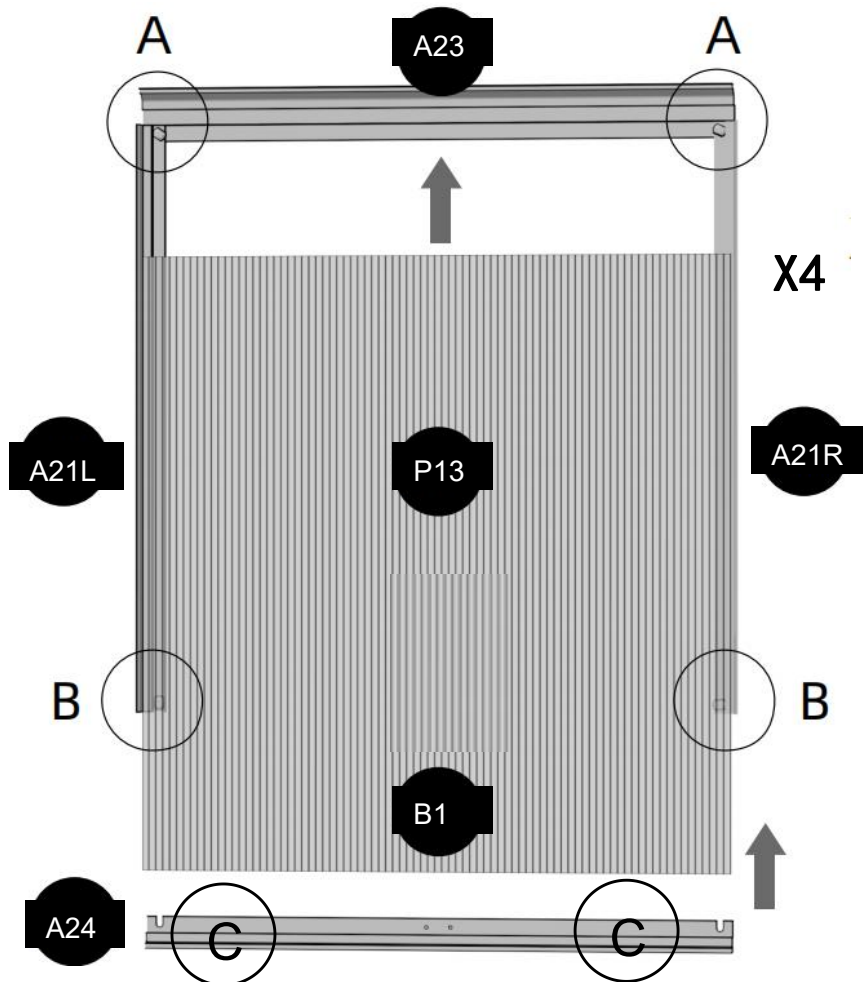

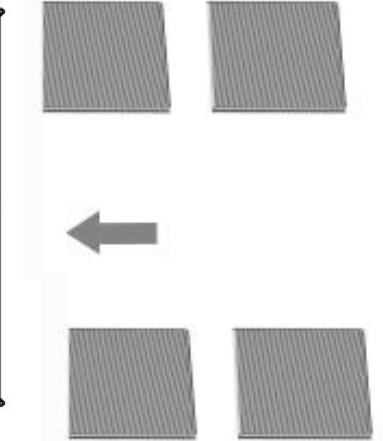
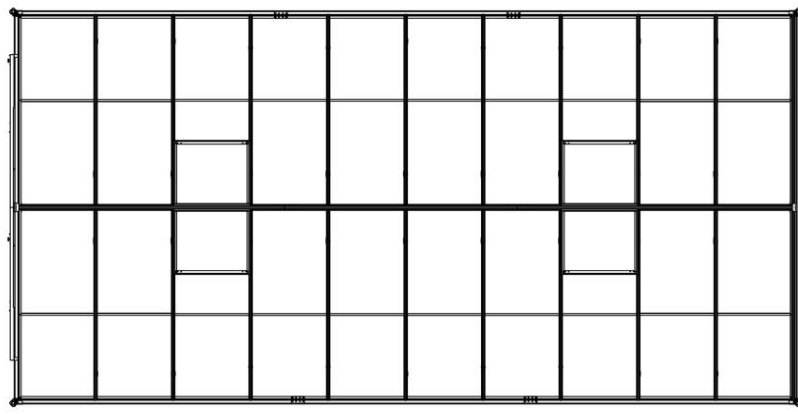
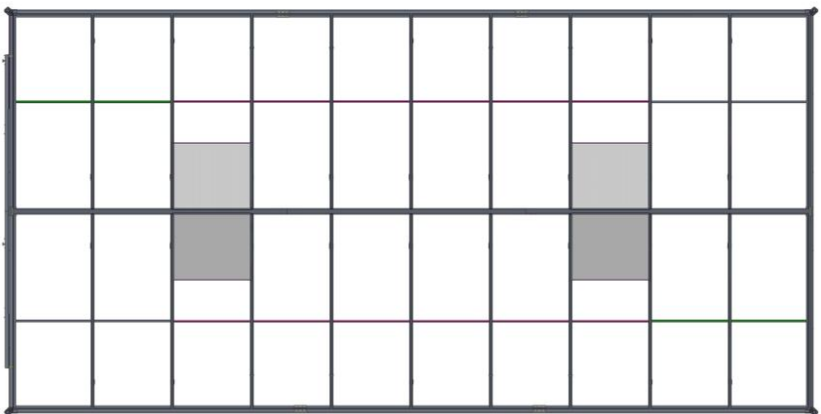
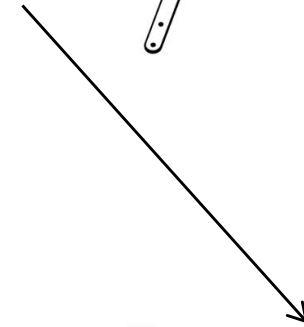
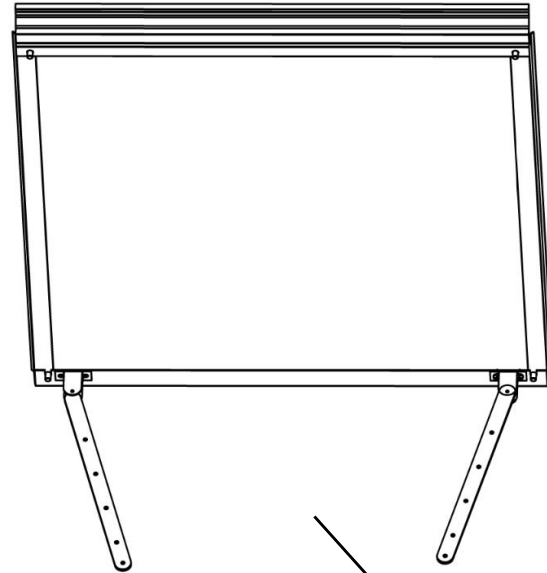
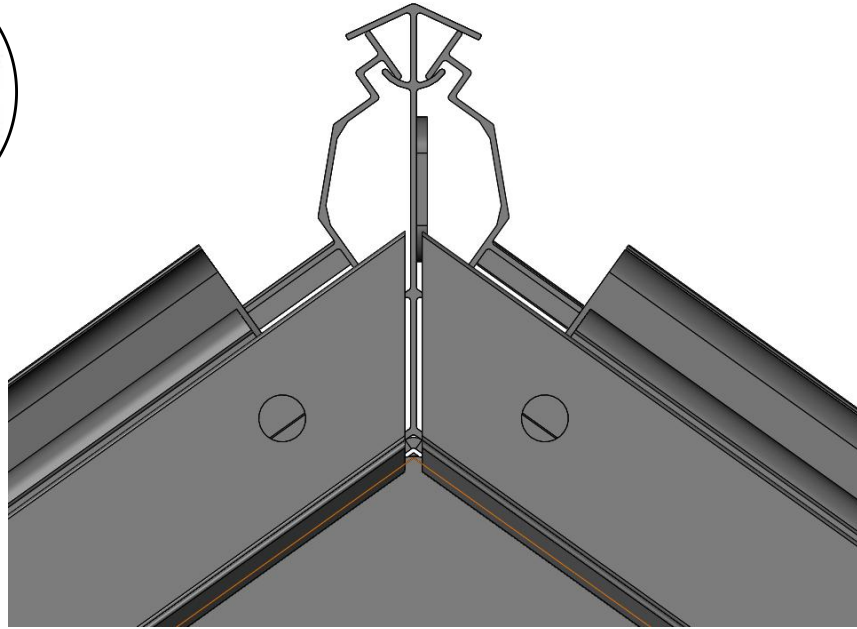
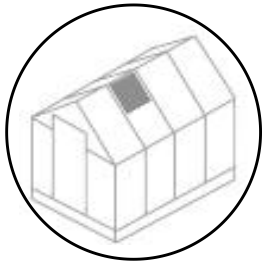

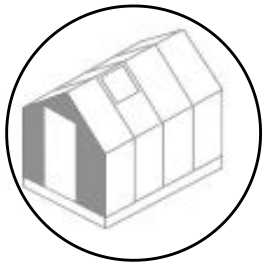

code Kod		Qty Ilość
P1		4
P4		5
P5		2
P6		2
P7		2
P11		2
A33		5

code Kod		Qty Ilość
A32		4
C11		8
B3		112
P8		2
P9		1
P10		2

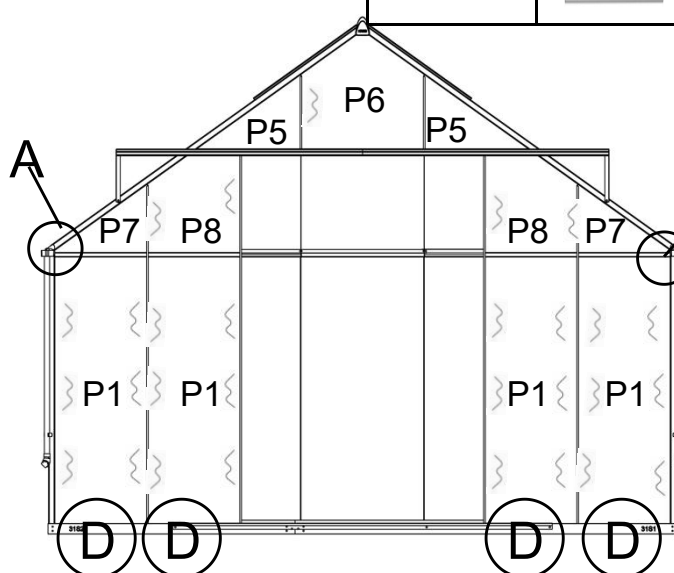
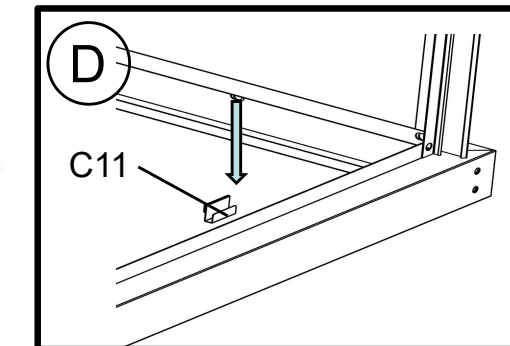
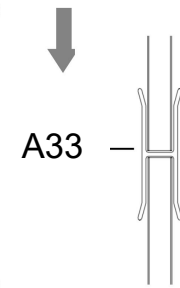
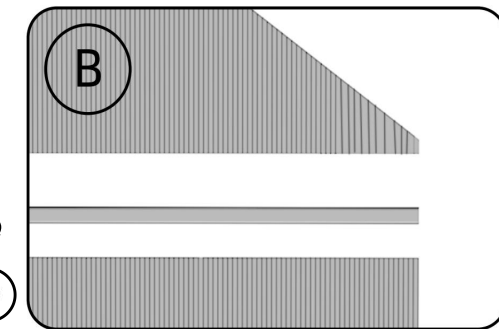
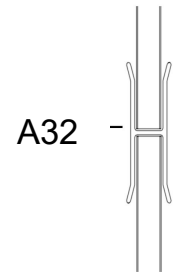
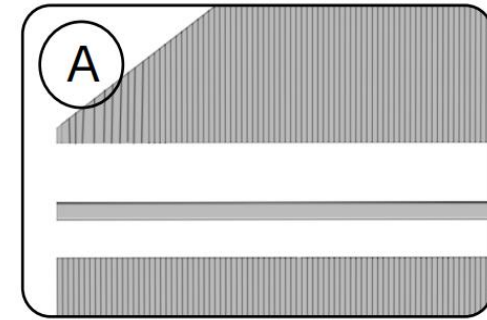
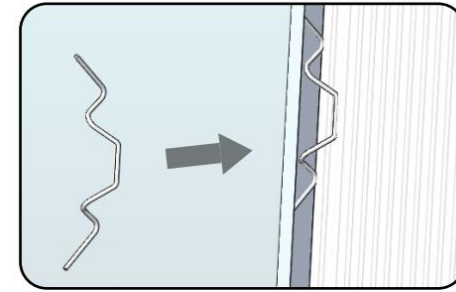

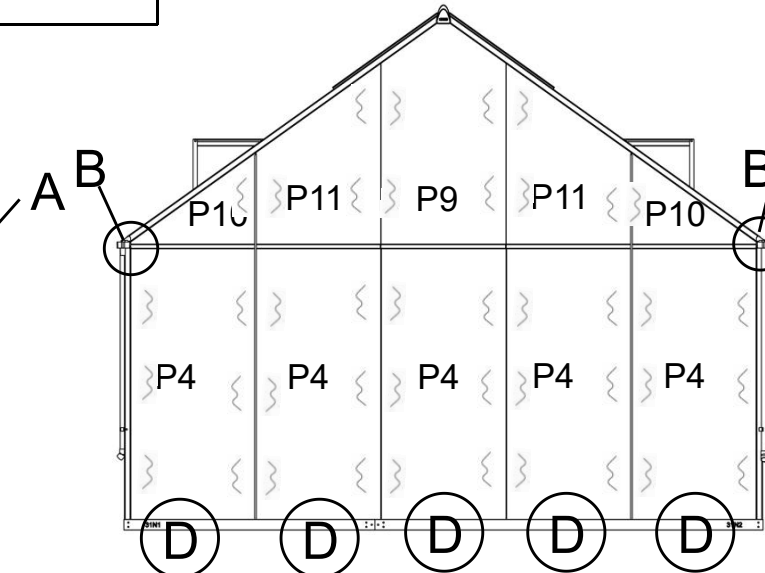

Front Przód



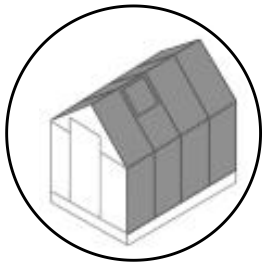



Back Tył

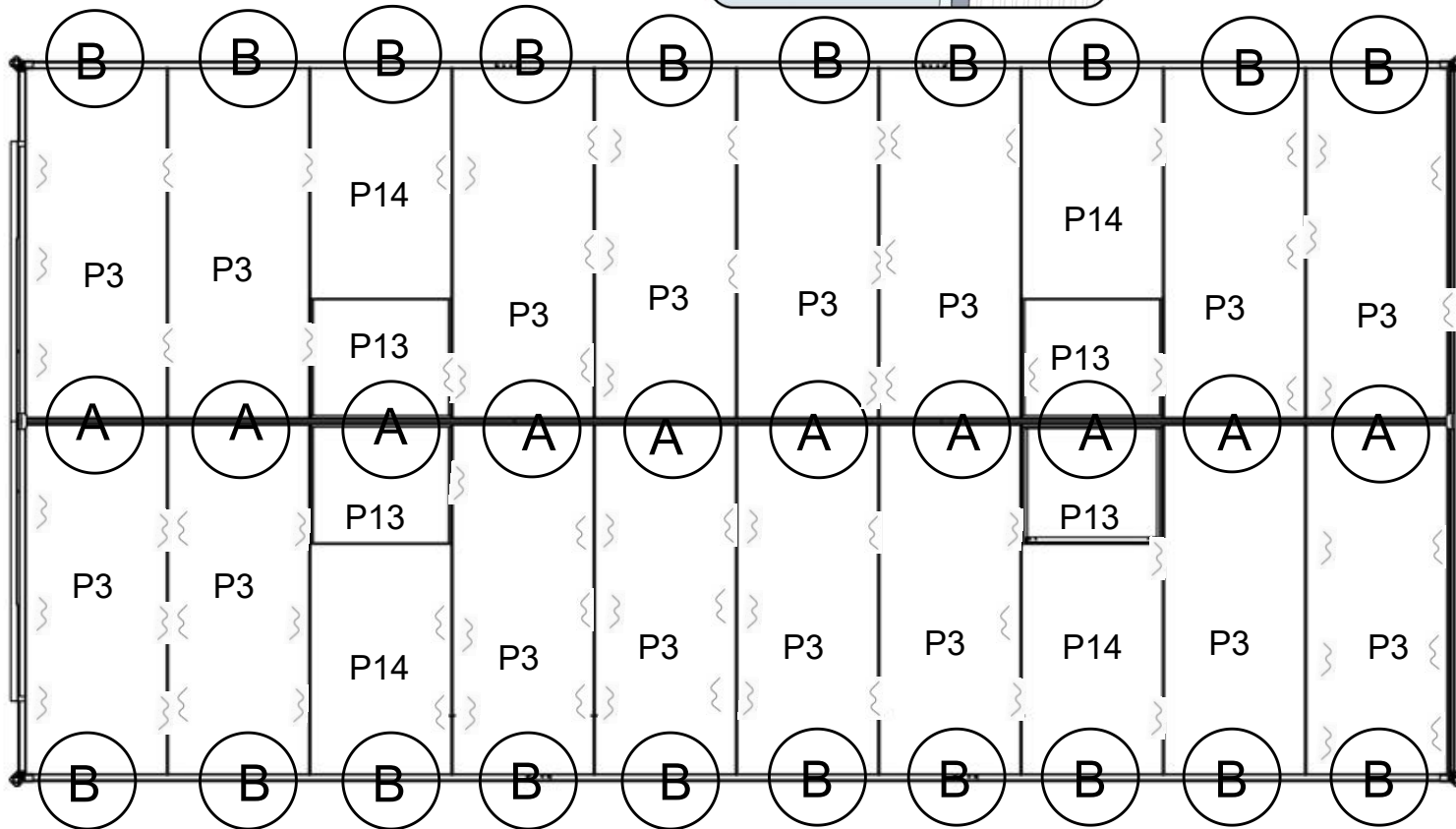
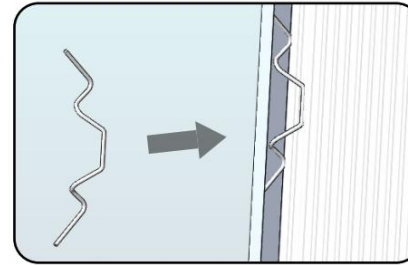
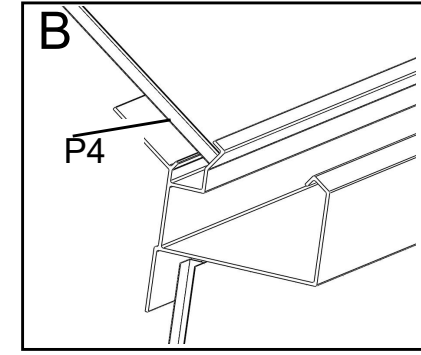
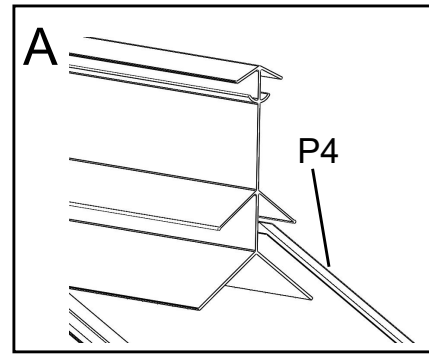

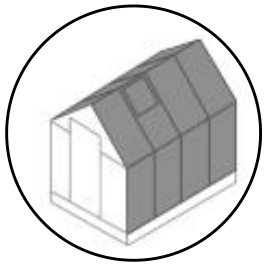





code Kod		Qty Ilość
P3		16
P14		4
B3		152

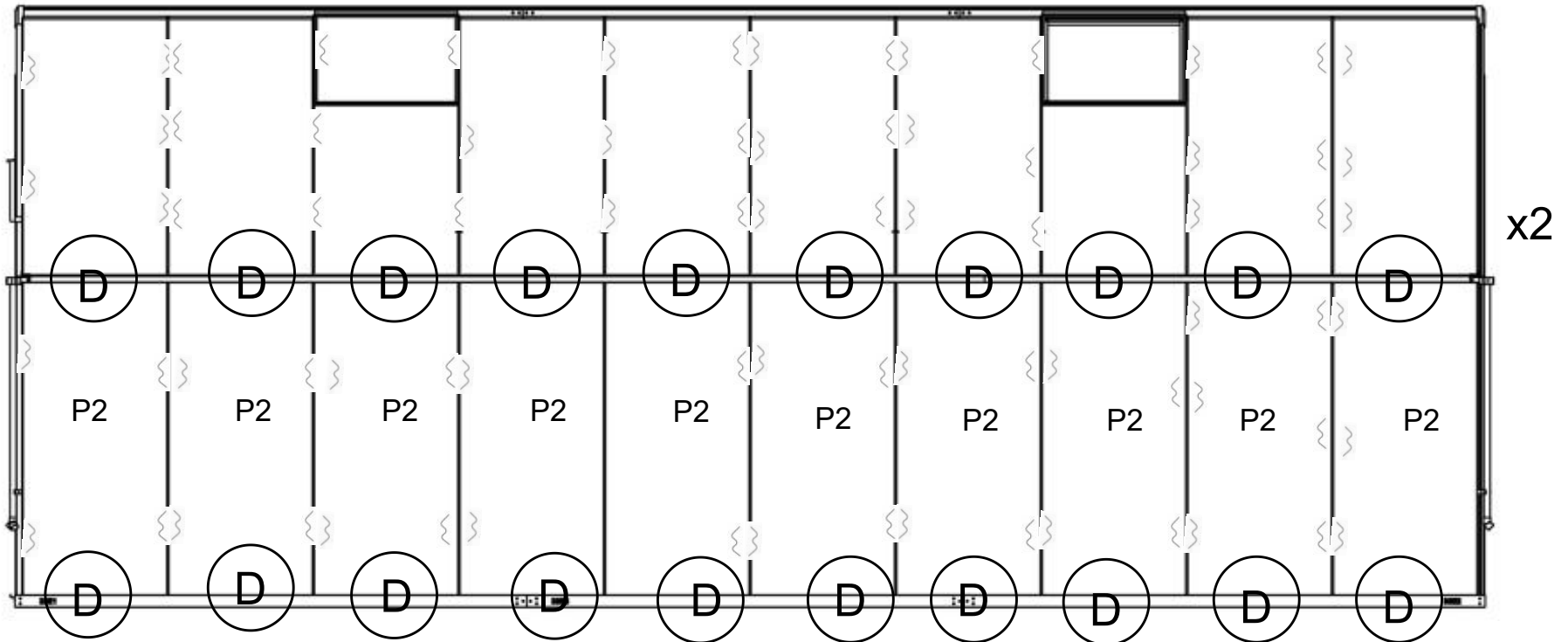
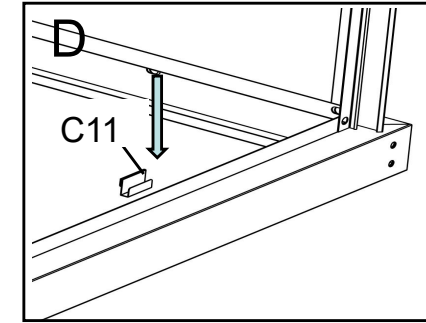
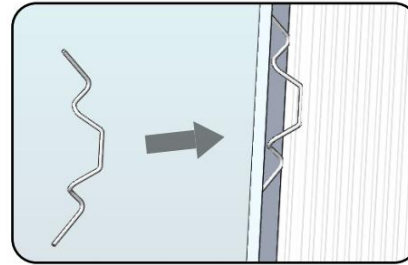



code Kod		Qty Ilość
P2		20
C11		32
B3		82

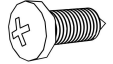

code Kod		Qty Ilość
R5		4
R6		4
R7		4
R2		2
R3		2
C12		4
F8		8

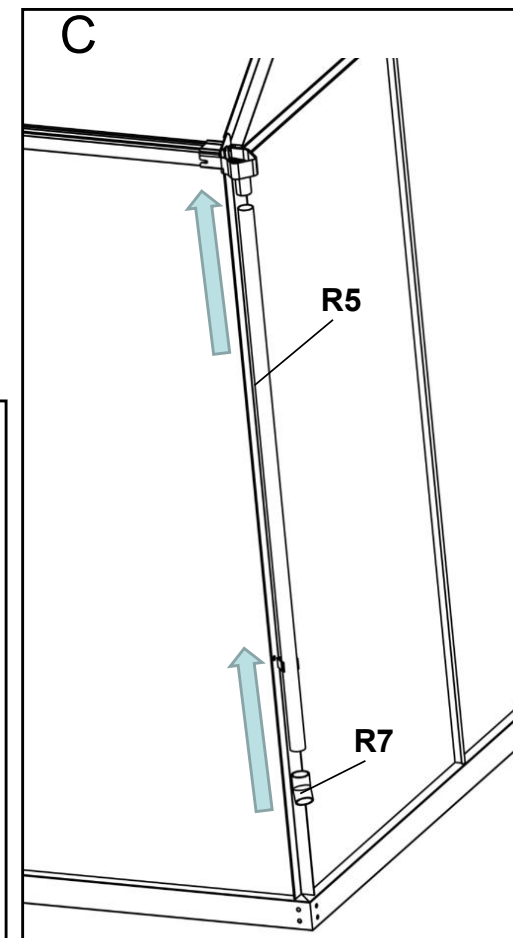
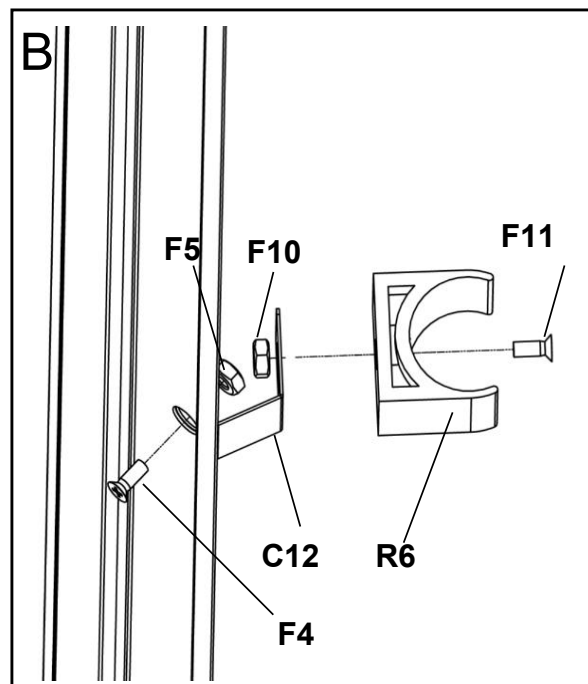
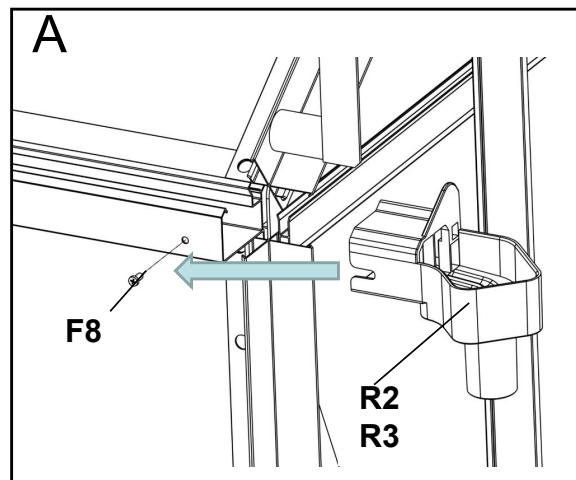
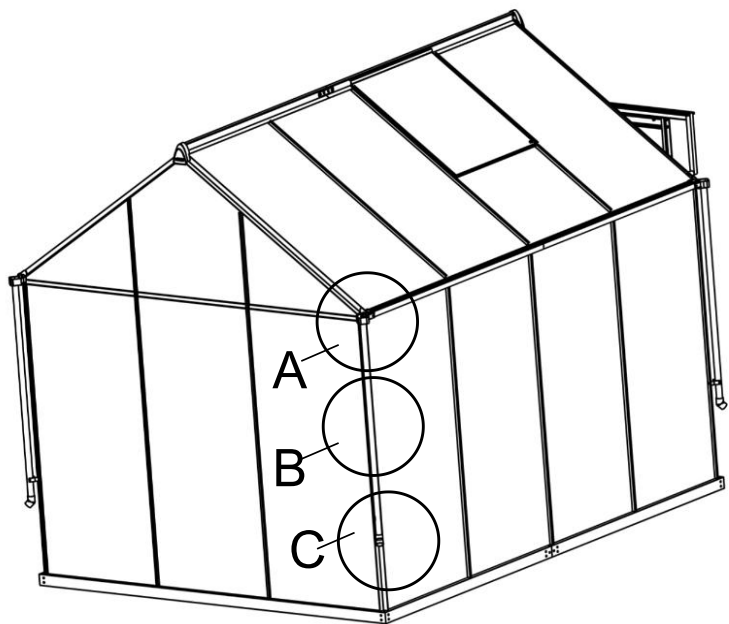

Notes:

1. Remove approximately 5cm of film from all sheet edges before installing. Remove all film immediately after the construction completed.
2. The UV-protected side of the sheet is covered with opal white film and must be face towards the sun.

Ważne:

1. Przed instalacją paneli zaleca się usunąć ze wszystkich krawędzi ok. 5cm folii. Usunąć folię całkowicie po zakończeniu montażu szklarni.
2. Strona zabezpieczona przed promieniowaniem UV jest pokryta białą folią i musi być skierowana na zewnątrz szklarni.

POLYCARBONATE PANEL PANEL Z POLIWĘGLANU

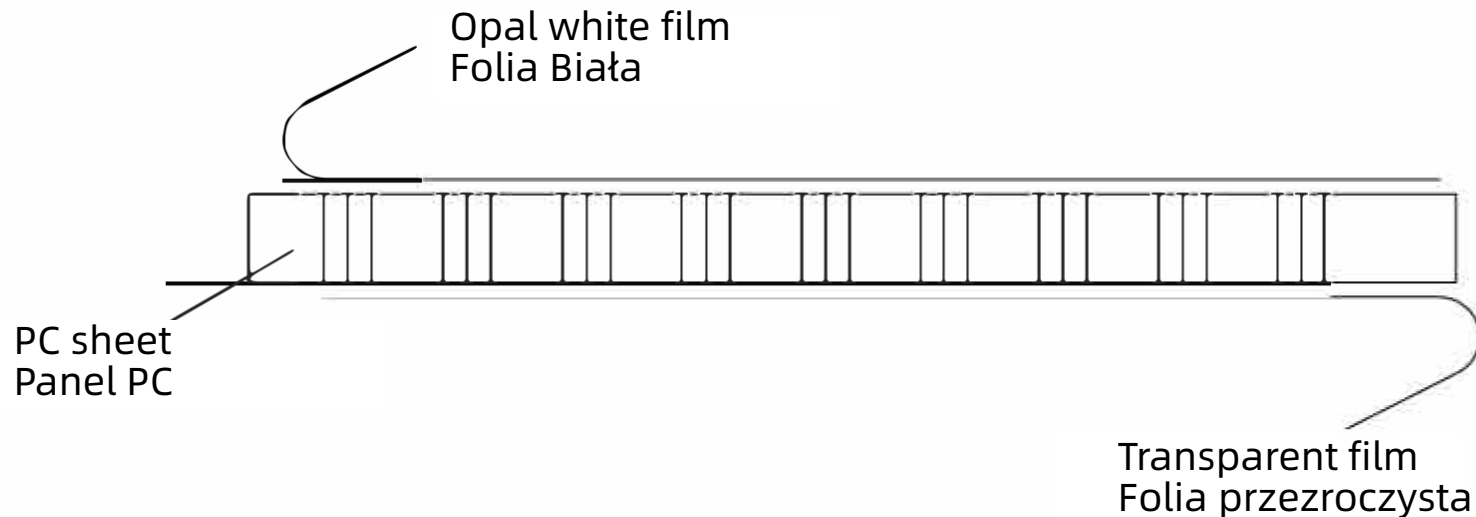

Two side of PC sheet are covered with thin film, one side`s film is transparent, another`s film is opal white. The UV-protect side of the sheet is covered with opal white and must face towards the outside.

Dwie strony panelu poliwęglanowego są pokryte cienką folią, z których jedna jest pokryta folią przezroczystą, natomiast druga folią białą. Strona chroniąca przed promieniowaniem UV jest pokryta folią białą i musi być skierowana na zewnątrz.

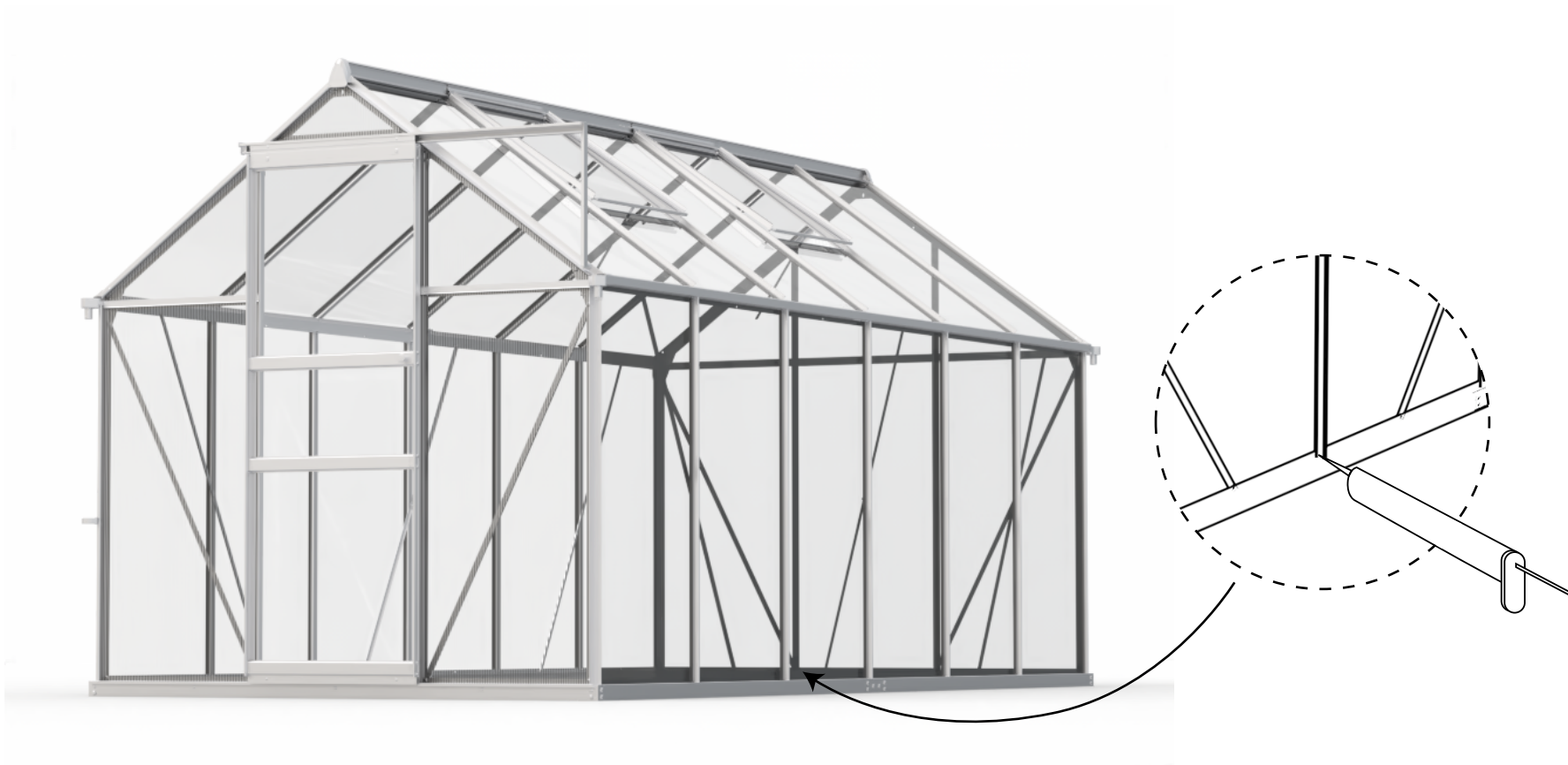

Advice Wskazówka

It is not necessary but we would advise:

For additional strength, you can also use some glue or tapes between the polycarbonate panel and the aluminium frame to enhance the stability.

Note: Silicone sealant and glue gun are not included in our tool kit. You can buy it locally. Only use silicone sealant suitable for aluminium.

Nie jest to konieczne, ale zalecamy:

Celem uzyskania dodatkowej ochrony przed wiatrem, opadami i owadami szklarnie można uszczelnić poprzez nałożenie kleju lub taśmy w miejscach łączeń paneli z profilami.

Uwaga: Uszczelniacz silikonowy i pistolet do kleju nie są zawarte w zestawie narzędzi, można je kupić w ogólnodostępnej sprzedaży. Prosimy stosować wyłącznie uszczelniacz silikonowy odpowiedni do aluminium.