

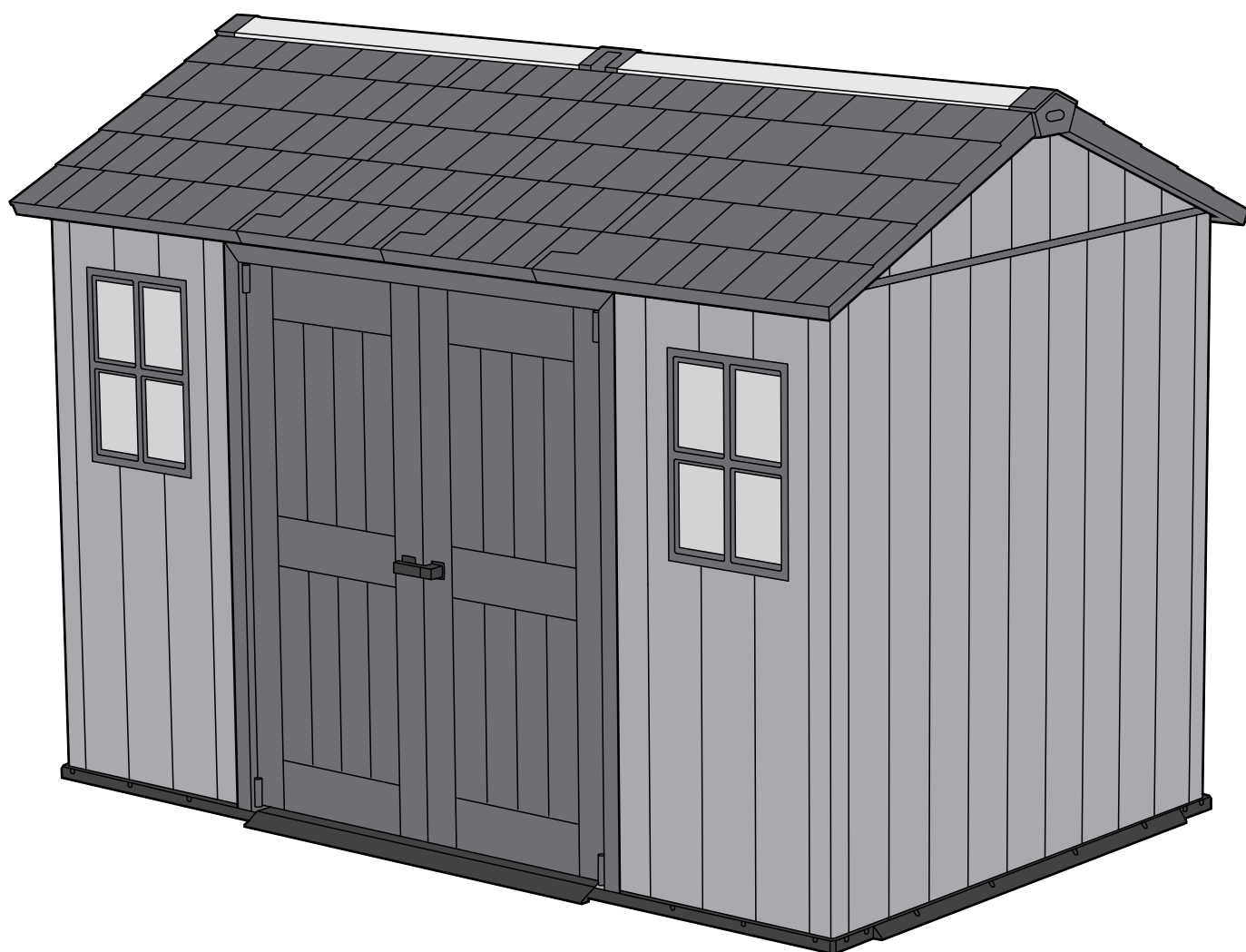

# OAKLAND 1175SD

INSTRUKCJA MONTAŻU



## PRZYGOTOWANIE MIEJSCA DO MONTAŻU

Wyrównać grunt.

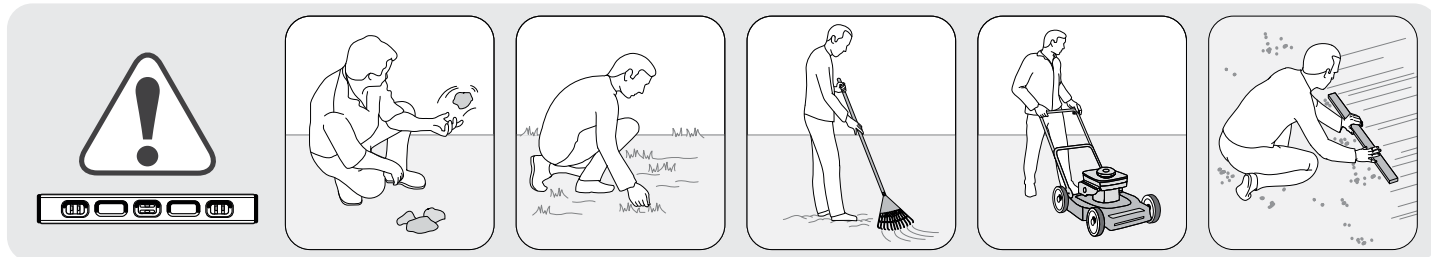

Zaleca się przygotowanie drewnianej lub betonowej podstawy jako fundamentu.

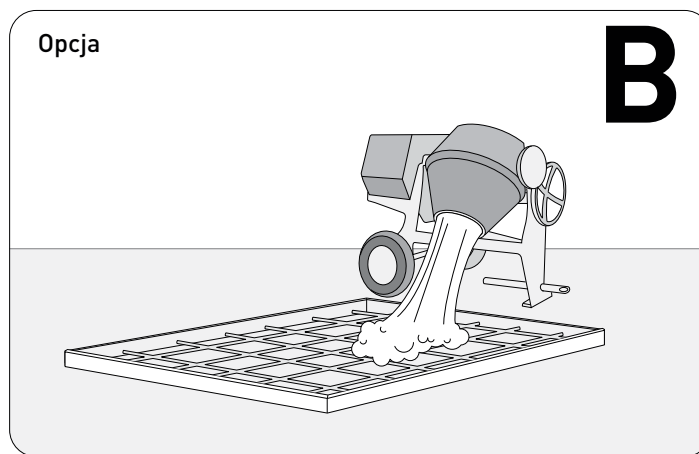
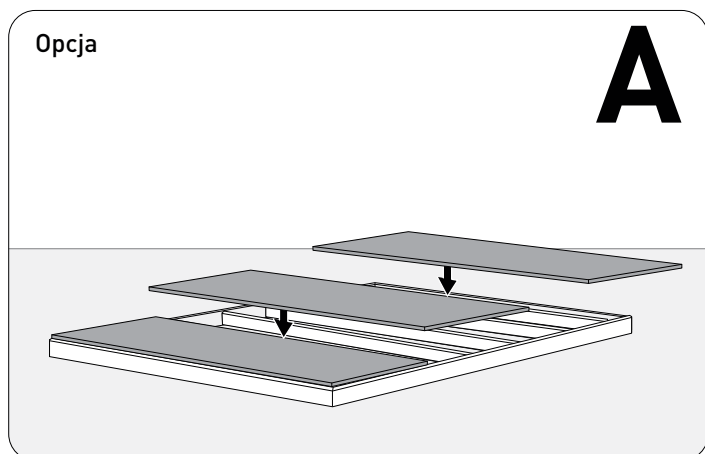

Do właściwego montażu należy zachować odpowiednią ilość wolnego miejsca wokół domku narzędziowego.

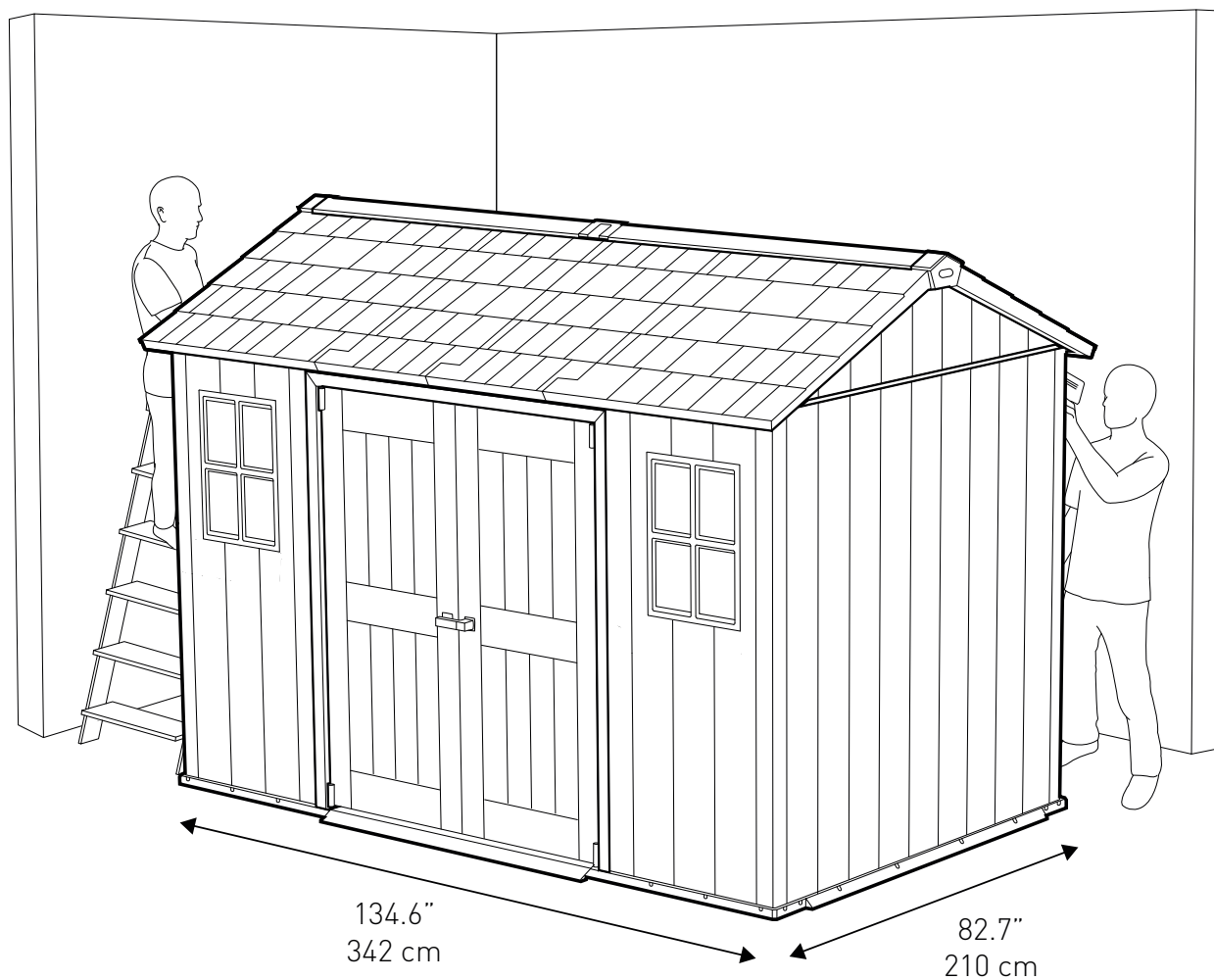

## PRZED ROZPOCZĘCIEM MONTAŻU

Należy zapoznać się z zaleceniami w zakresie bezpieczeństwa umieszczonymi na końcu tej instrukcji. Przed przystąpieniem do montażu należy zapoznać się z instrukcją. Montaż wszystkich elementów powinien być wykonany zgodnie z instrukcją. Nie należy pomijać żadnego z etapów.

## WYMAGANE NARZĘDZIA



DO MONTAŻU POTRZEBNE SĄ DWIE OSOBY

## CZĘŚCI DOMKU NARZĘDZIOWEGO

Wszystkie elementy należy wyciągnąć z opakowania (-ań) i rozłożyć na uprzednio przygotowanej do pracy powierzchni. Dla łatwiejszej identyfikacji części oznaczone są literami.

### CZĘŚCI PODŁOGI

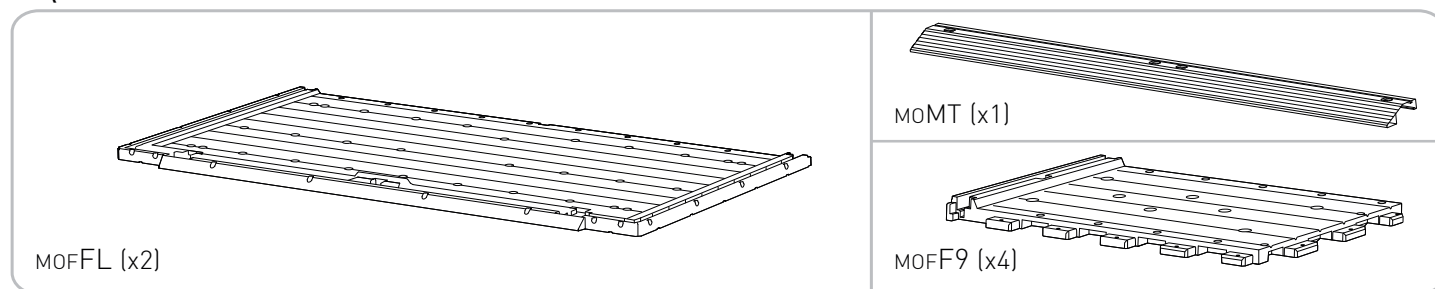

### CZĘŚCI ŚCIANY

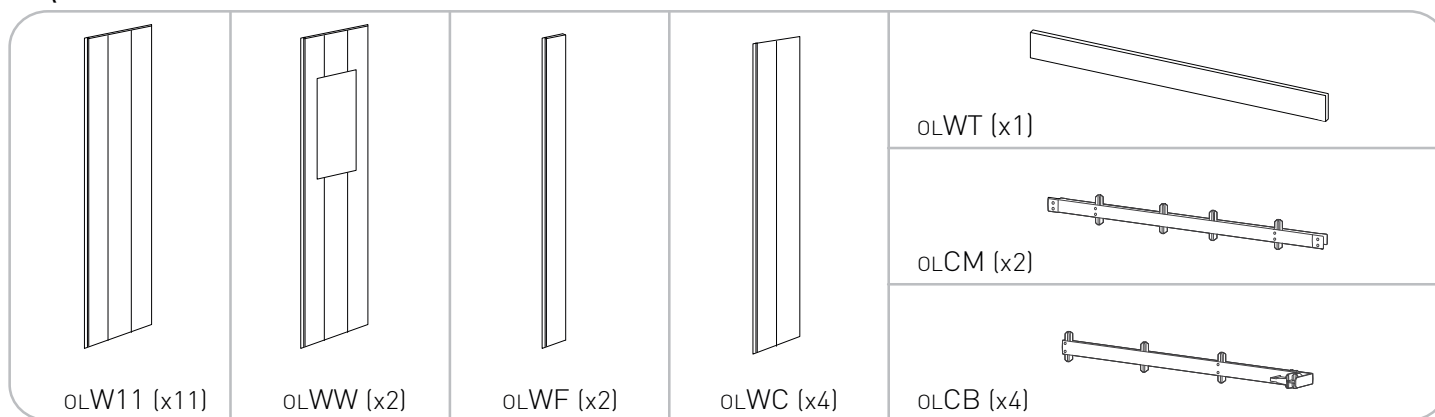

### CZĘŚCI DRZWI

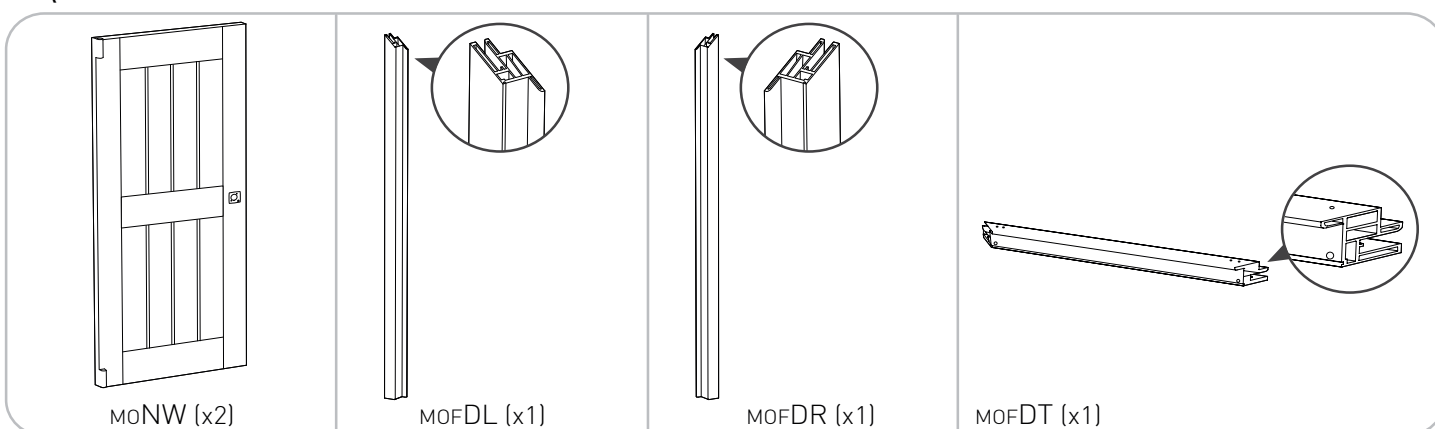

## CZĘŚCI DACHU

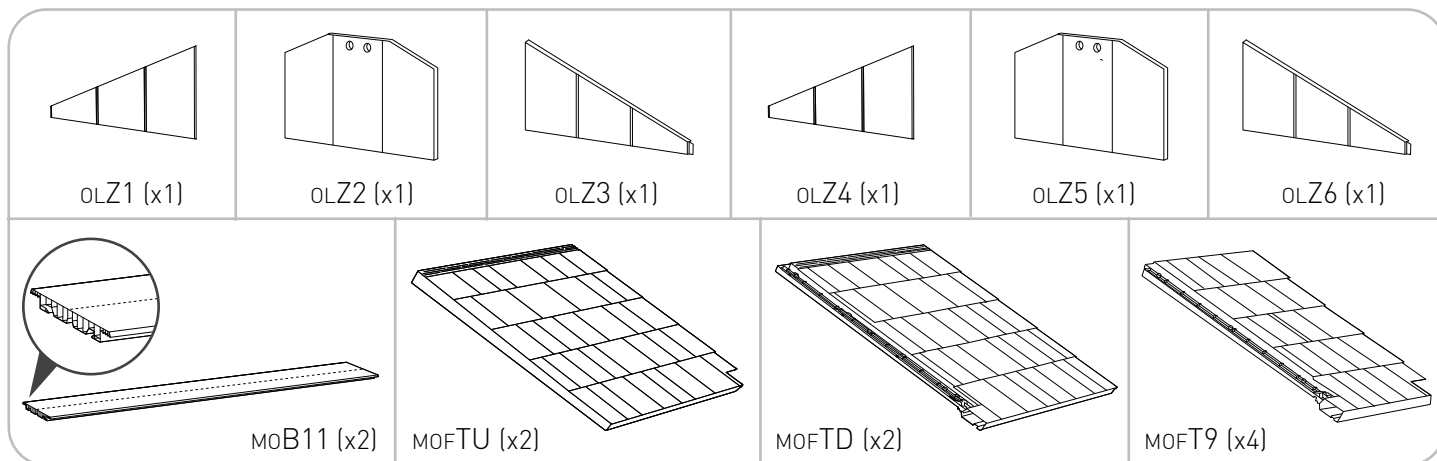



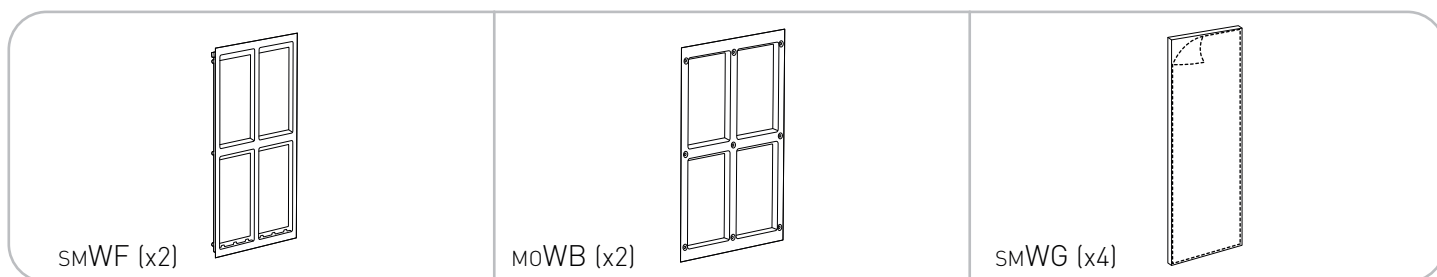



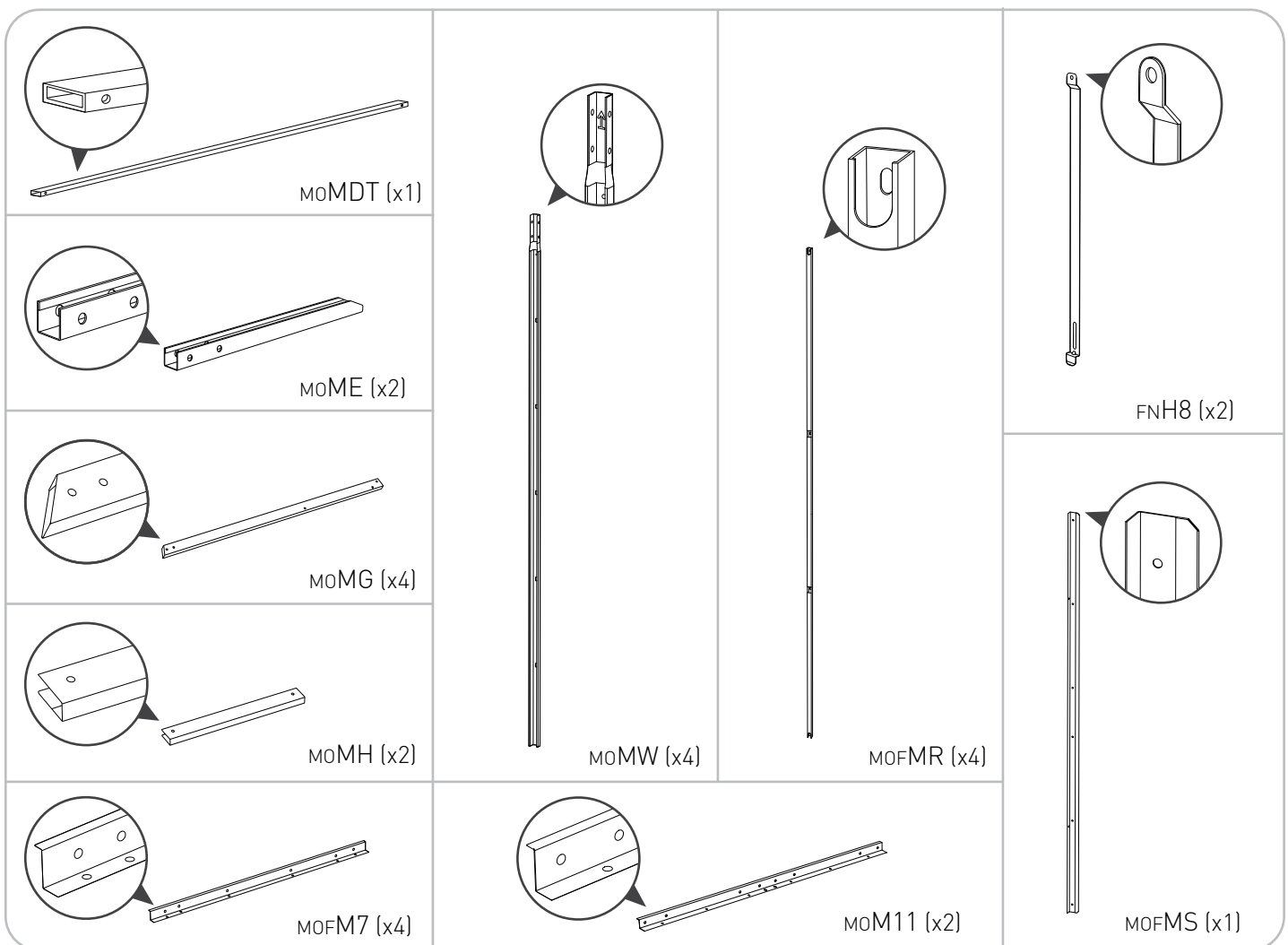



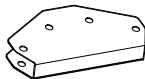
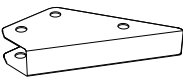
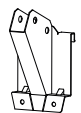
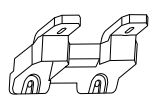

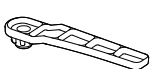

## CZĘŚCI OKIEN

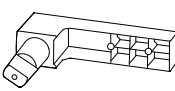
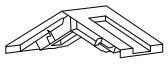
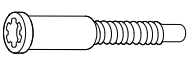

## CZĘŚCI METALOWE

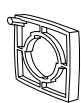
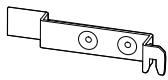

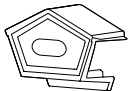
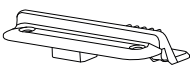
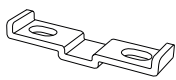
## DROBNE CZĘŚCI

 FNCH (x2)	 MoMA (x2)	 FNME (x2)	 MoMC (x2)	 MoFTC (x4)
 FN TM (x8)	 MoAK (x2)	 FNHL (x1)	 MoFDC (x2)	 FNH3 (x1)
 FNH5 (x1)	 FNH6 (x1)	 FNH1 (x1)	 MoBC9 (x1)	 FNHD (x4)
 KP (x18)	 FNHA (x2)	 FNH4 (x1)	 FNH2 (x1)	 FNH7 (x1)
 MoPLS (x2)	 MoAC (x2)	 oLFS (x1)	 MoRC (x6)	 oLHC (x2)

## ŚRUBY I WKRETY

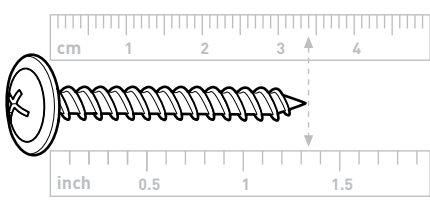
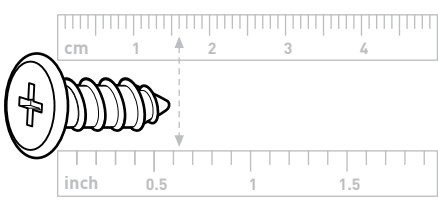
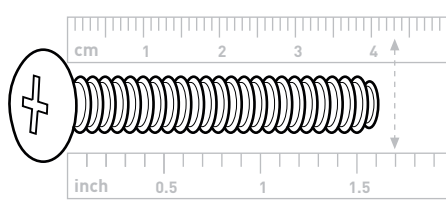
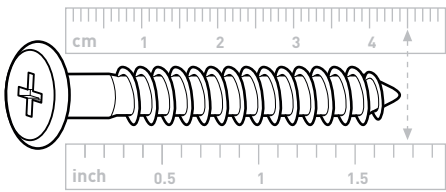
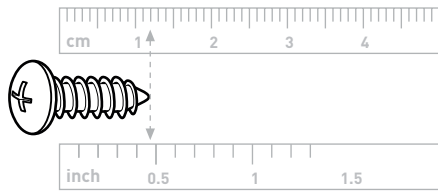
 sc12 (x49) 34 mm / 1.38"	 sc15 (x404) 16 mm / 0.63"	 sc8 (x26) 43 mm / 1.69"
 s45b (x16) 45 mm / 1.77"	 FNH9 (x2)	 scn8 (x26)
 s13b (x66) 12 mm / 0.47"		

Opakowanie może zawierać również dodatkowe małe części, które mogą być wykorzystane jako części zamienne.

**UWAGA:** Ze względu na uwarunkowania wynikające z procesu produkcji, po złożeniu domku jego rzeczywisty rozmiar może nieznacznie różnić się od wymiarów podanych w specyfikacji.

## MONTAŻ PODŁOGI

1

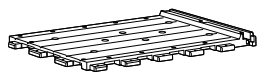

MOFF9 (x4)

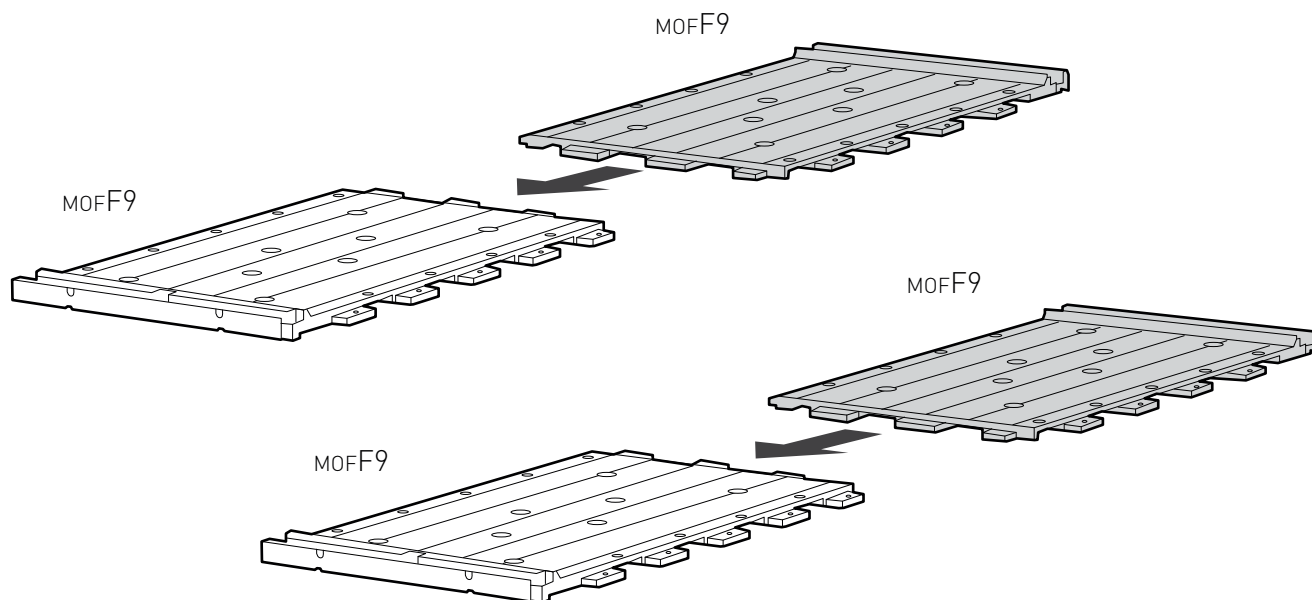
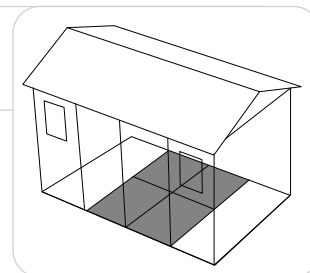

2



sc15 (x8)

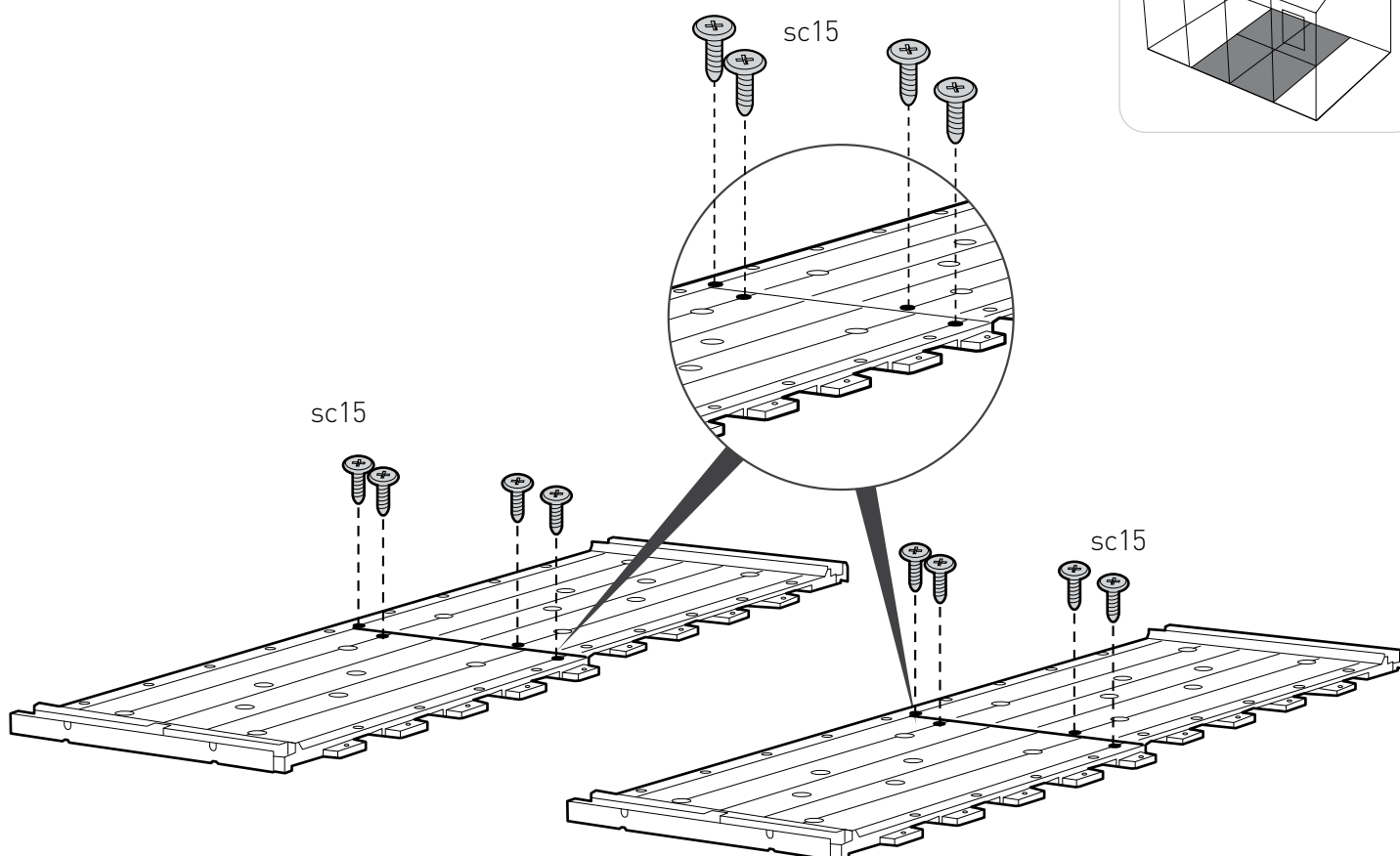
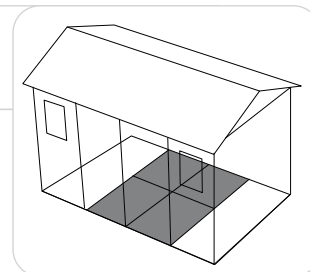

3



(x2)

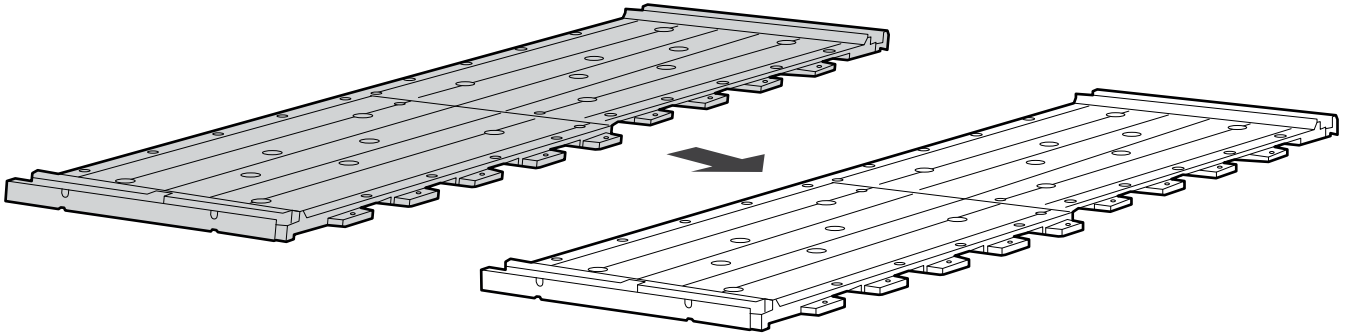
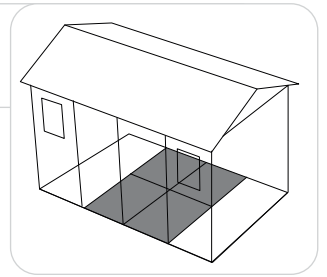

4

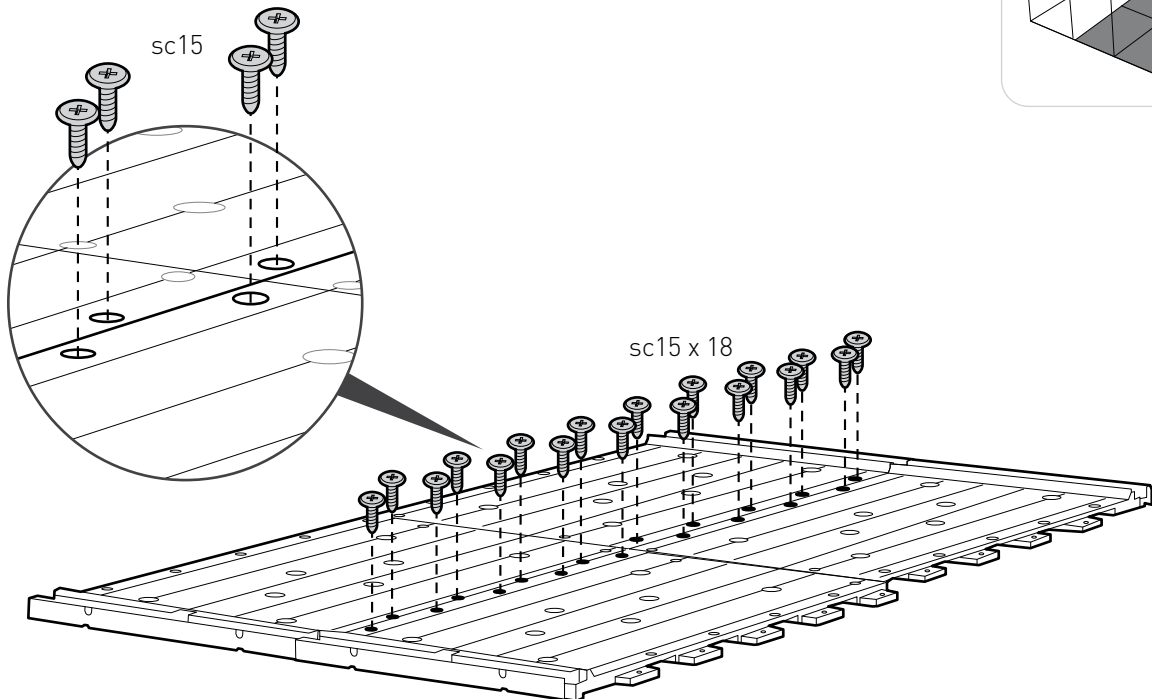
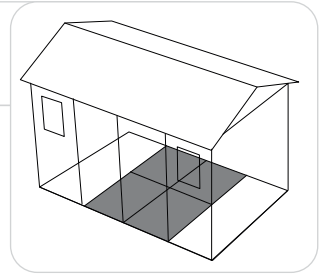

5

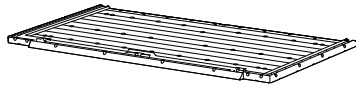
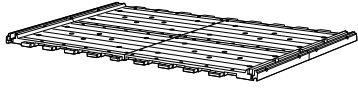

MOFFL (x2)

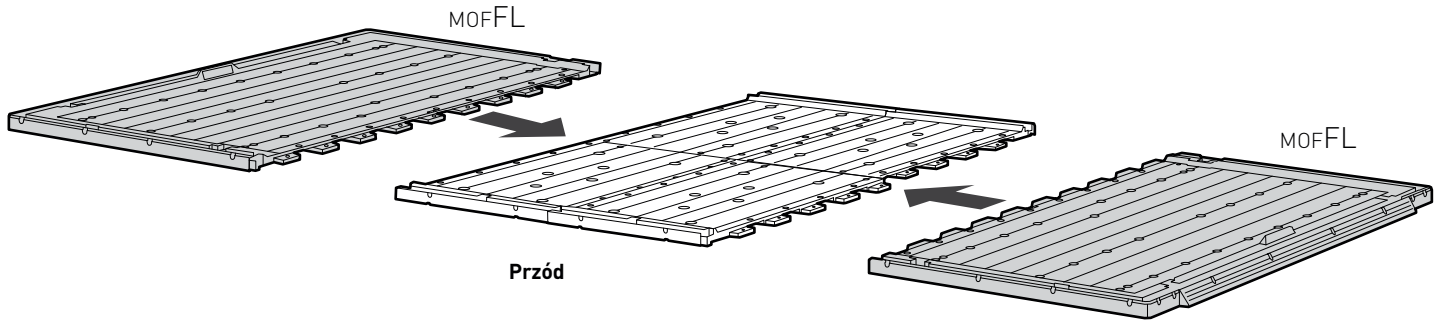
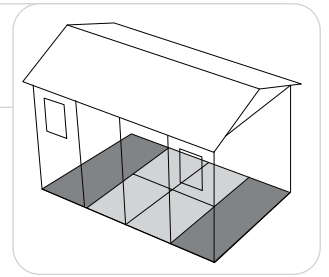

6

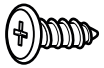

sc15 (x36)

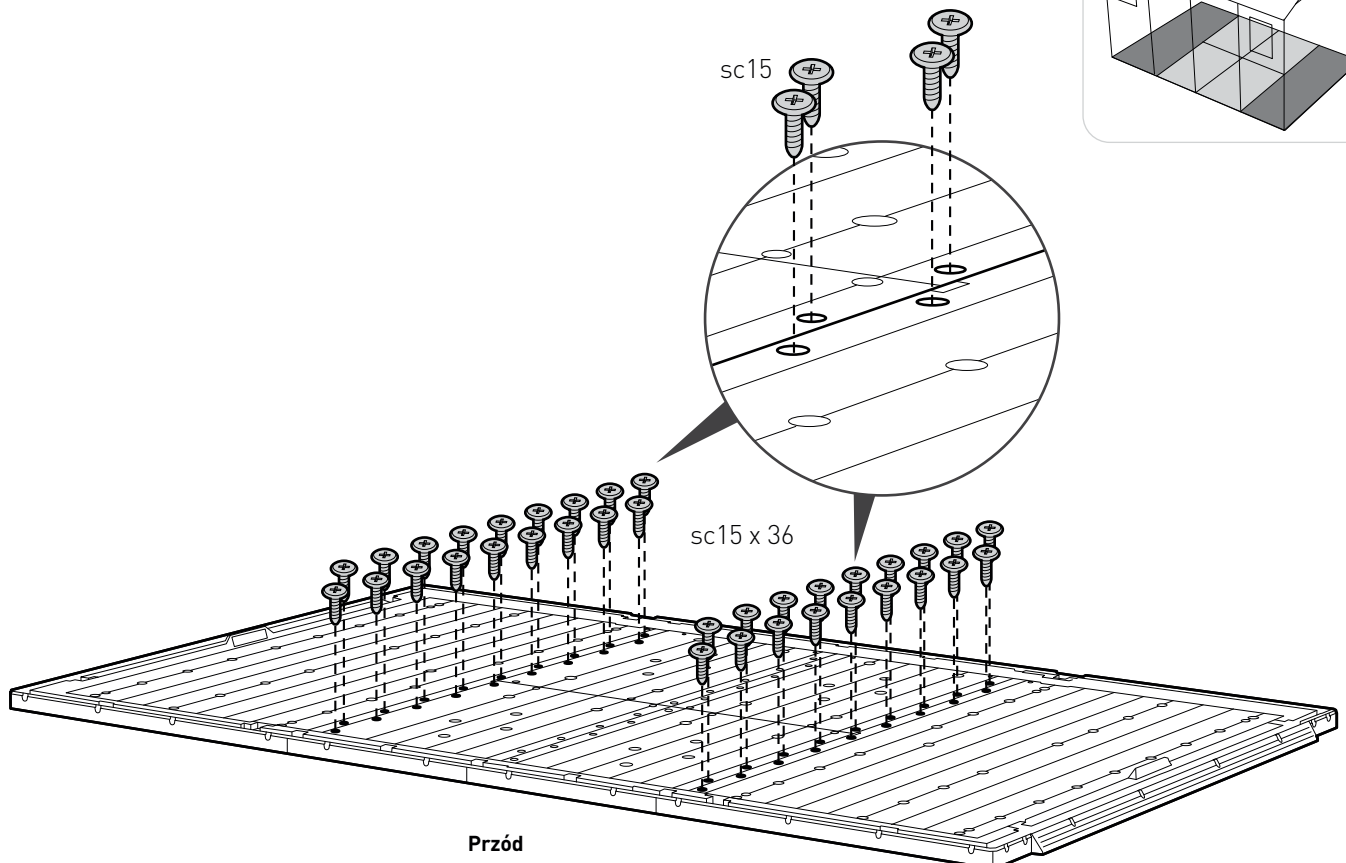
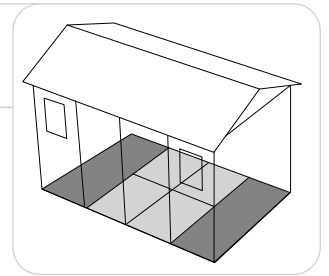



# MONTAŻ ŚCIAN

7



oLWC (x1)

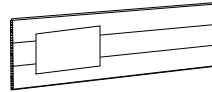

oLWW (x1)

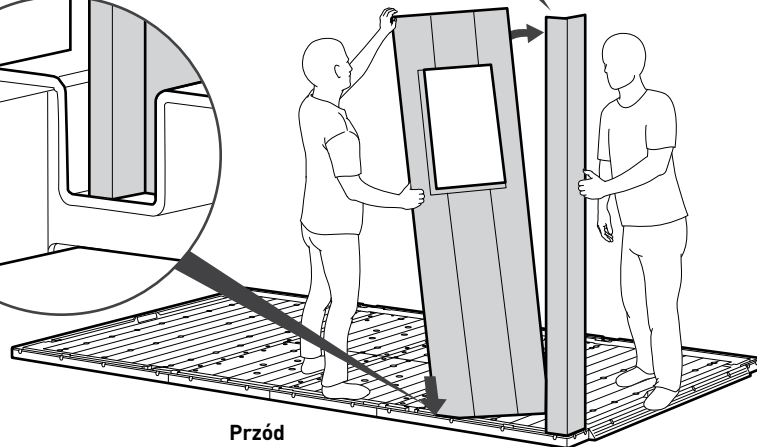
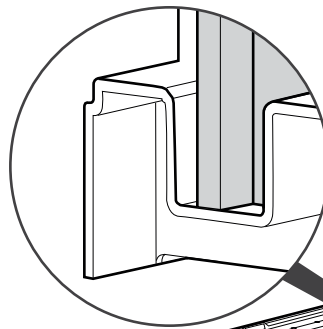
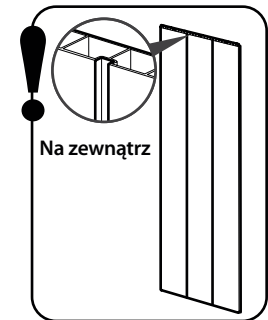
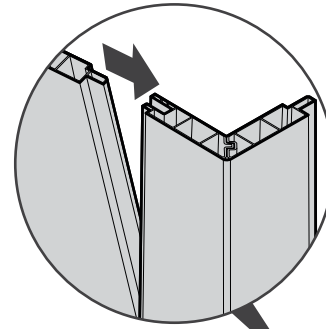
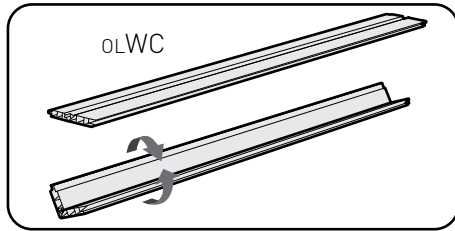
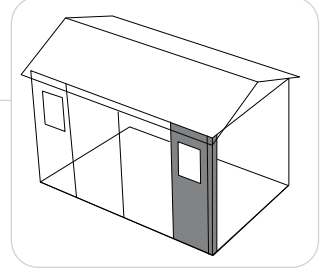

8



KP (x1)



s13b (x1)

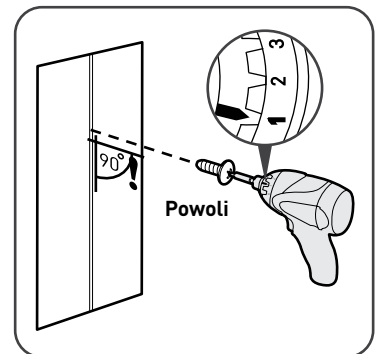
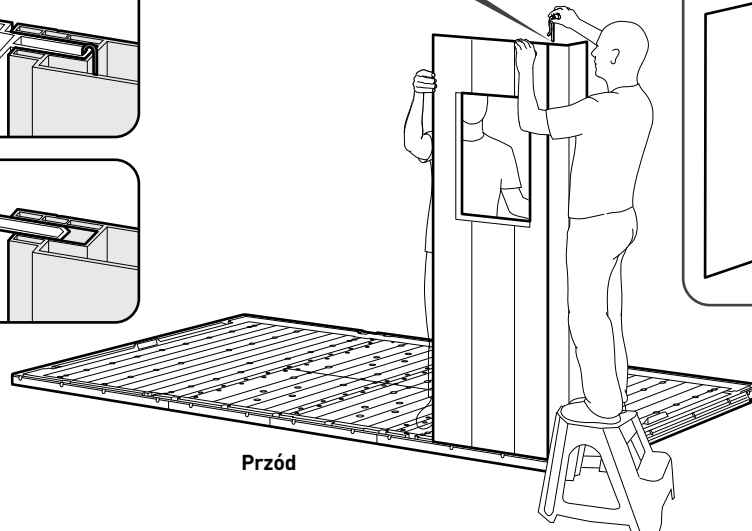
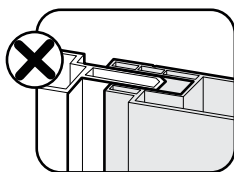
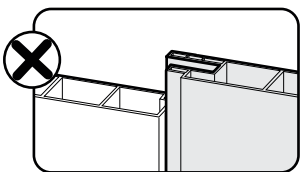
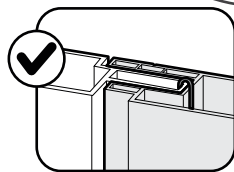
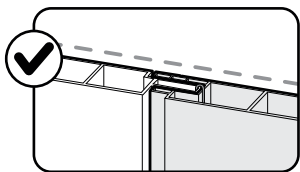
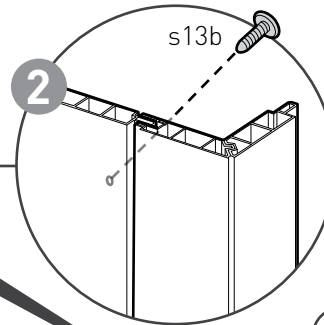
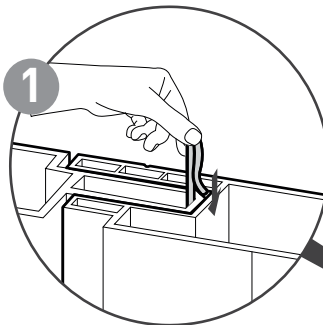
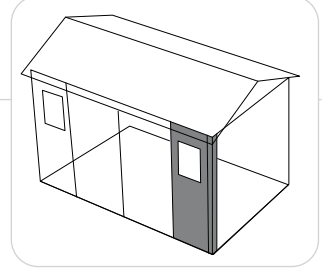

9



oLW11 (x3)



KP (x3)



s13b (x3)

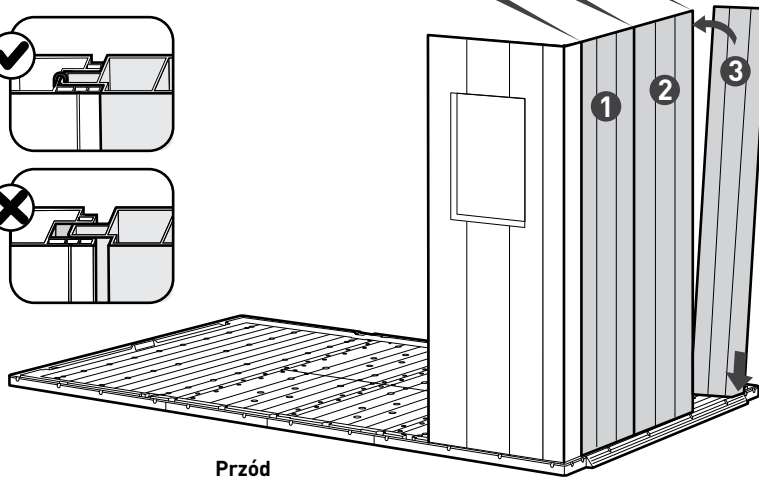
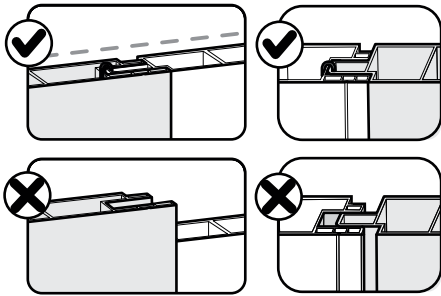
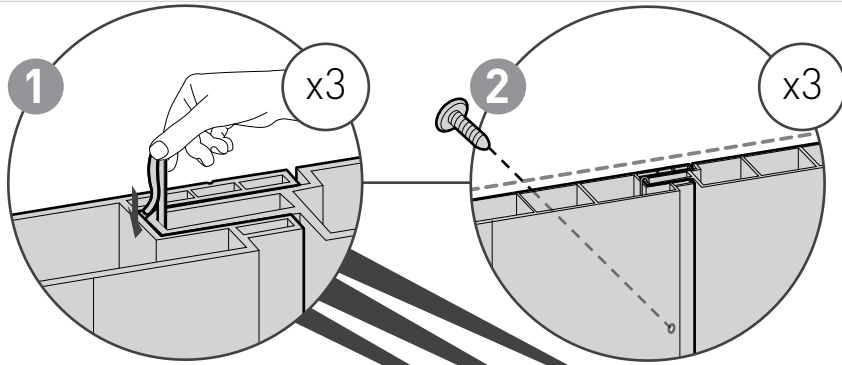
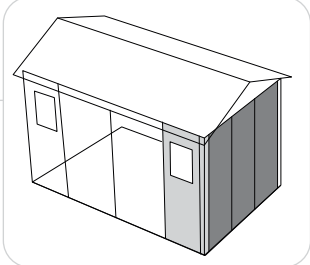

10



oLWC (x1)



oLW11 (x3)

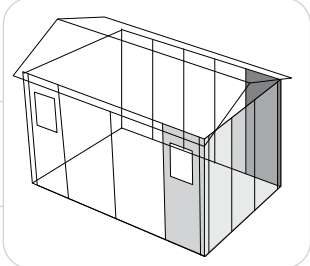





KP (x2)

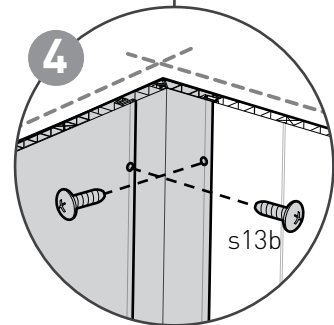
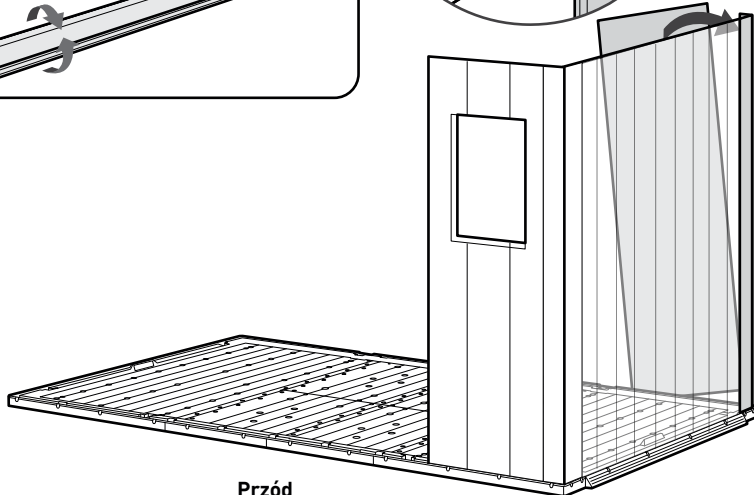
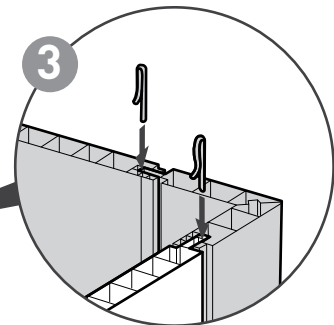
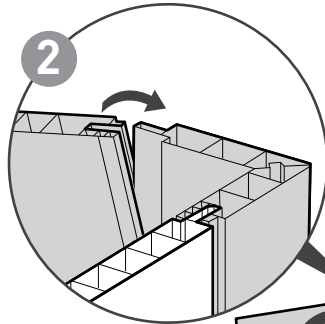
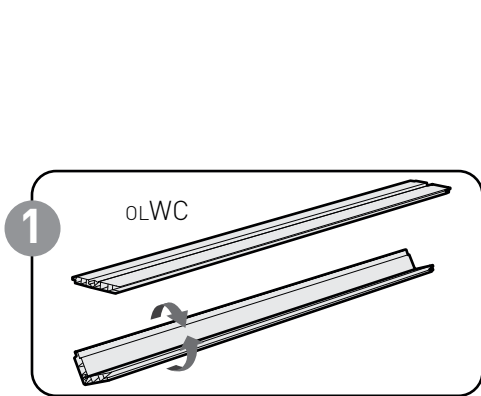



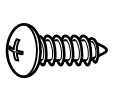

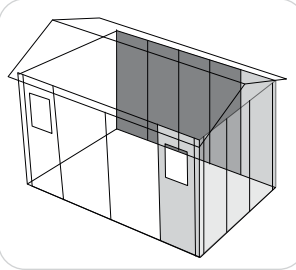
s13b (x2)

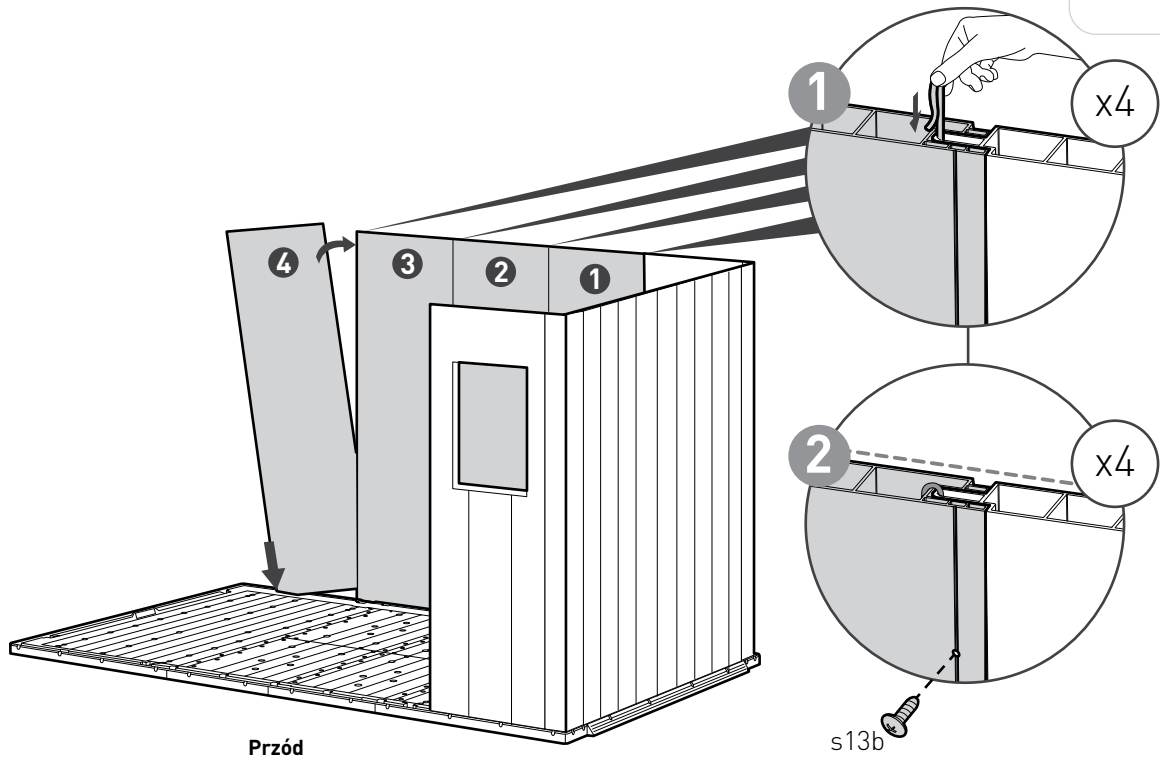

11 |  oLW11 (x4) |  KP (x4) |  s13b (x4) |  

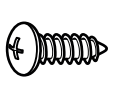

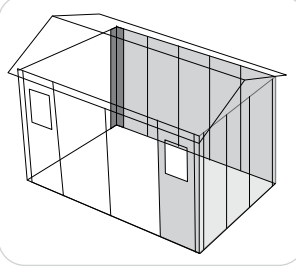
12 |  oLWC (x1) |  KP (x1) |  s13b (x1) |  

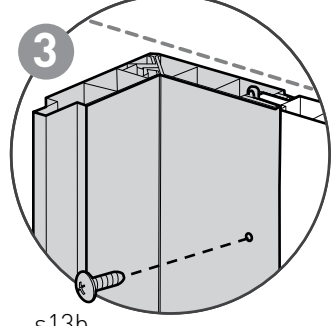
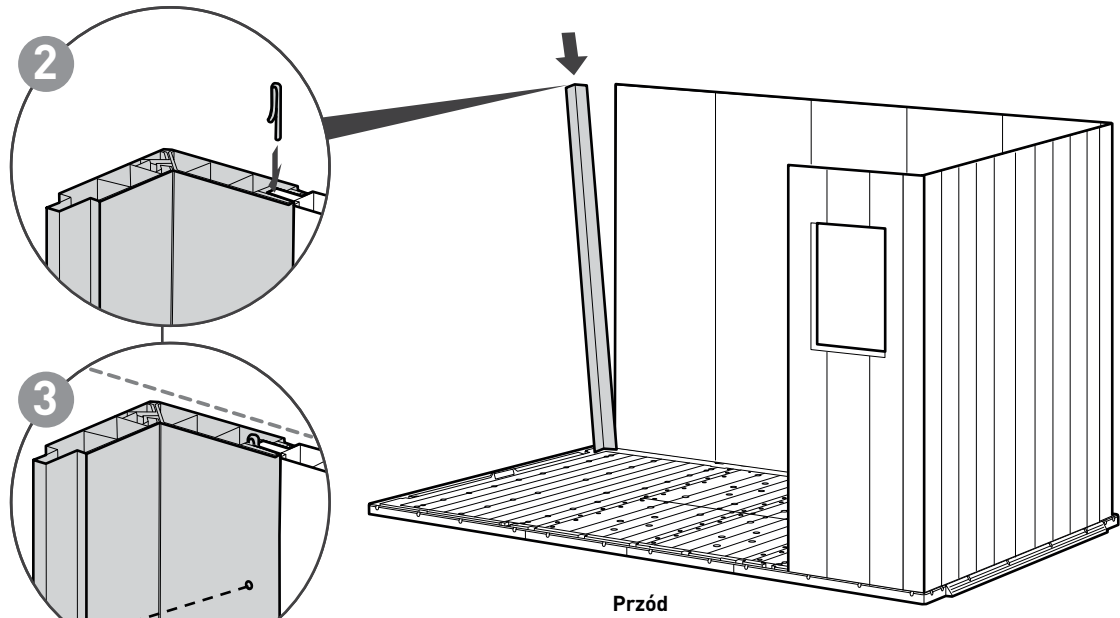
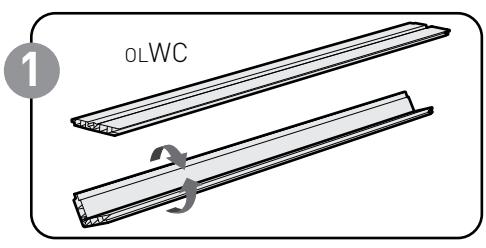

13



oLW11 (x3)



KP (x3)



s13b (x3)

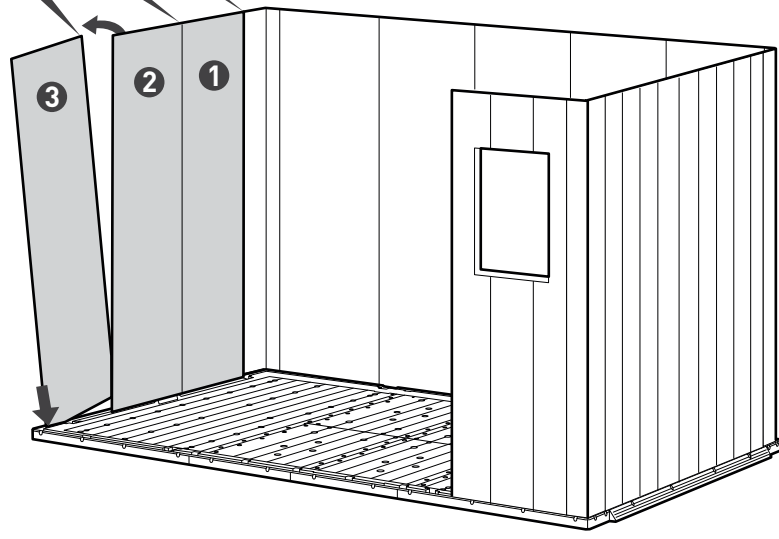
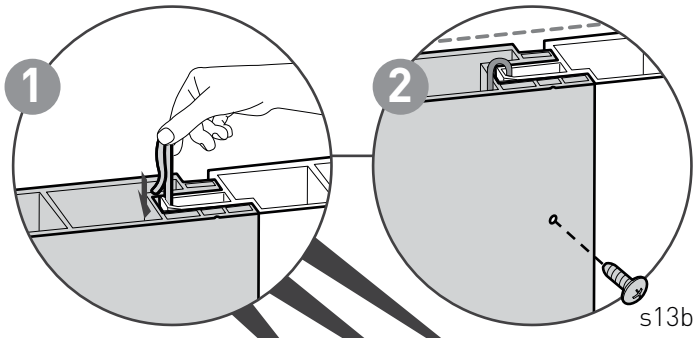
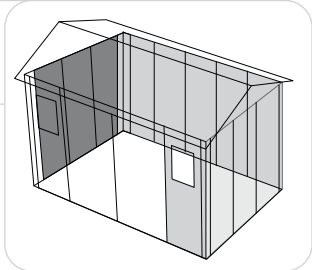

14



oLWC (x1)

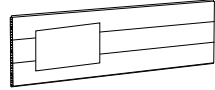

oLWW (x1)

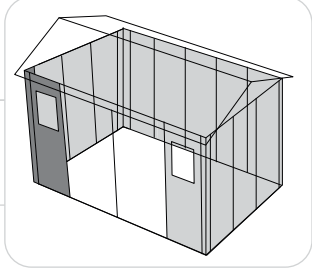

KP (x2)



s13b (x2)

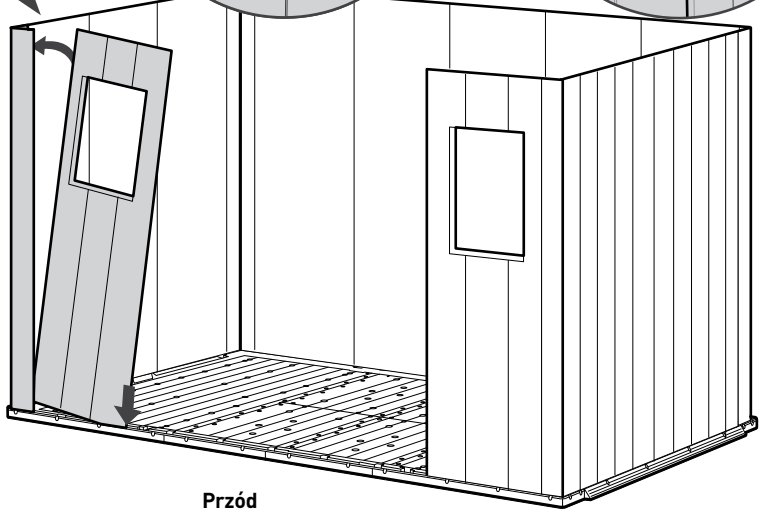
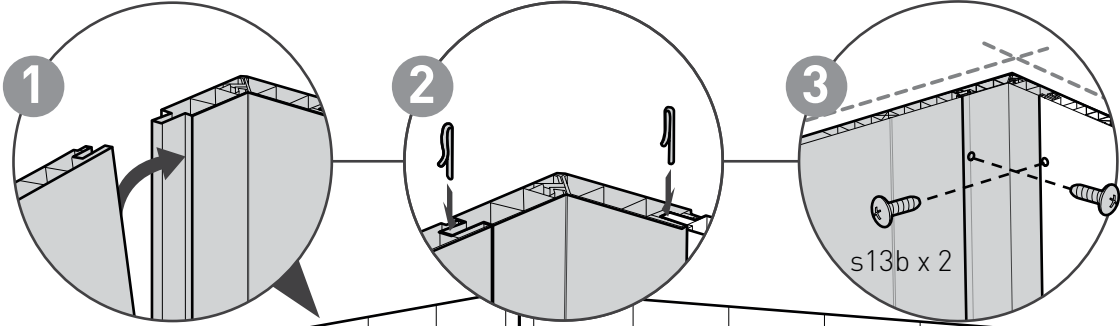

Przód

15

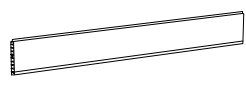

oLWF (x2)



KP (x2)

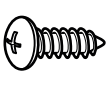

s13b (x2)

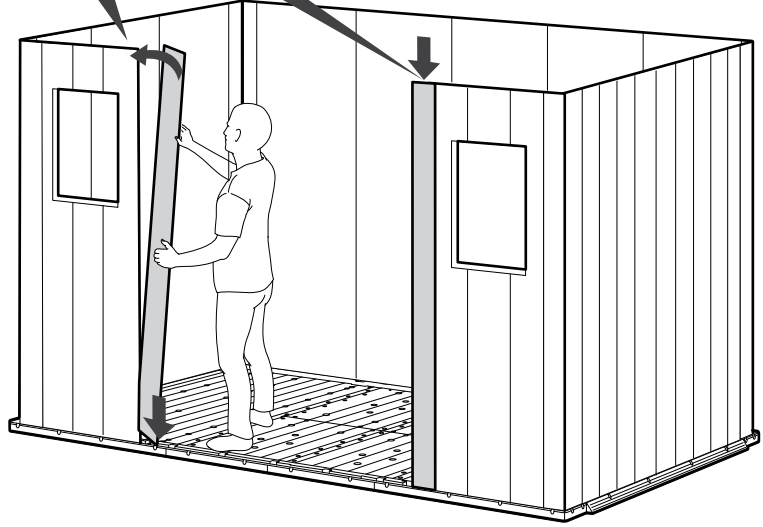
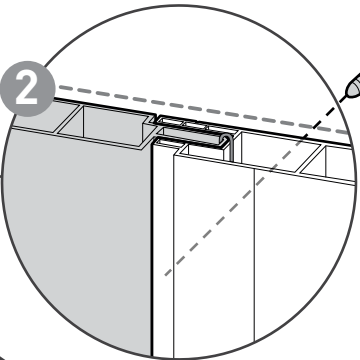
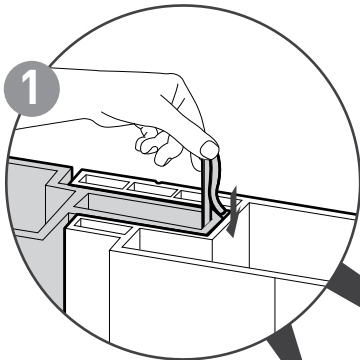
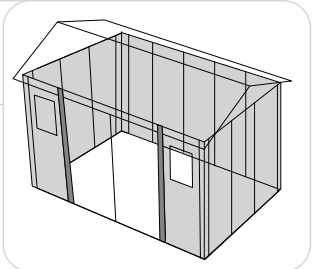

16

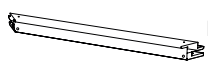

MoFDT (x1)



MoMDT (x1)



s13b (x2)

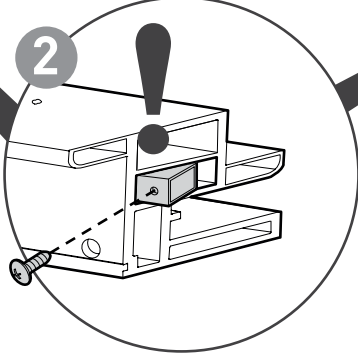
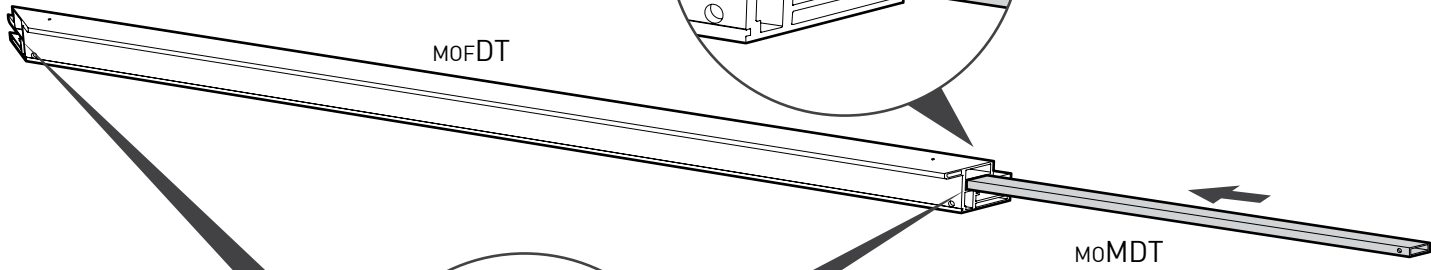
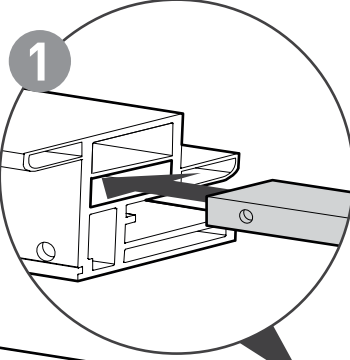
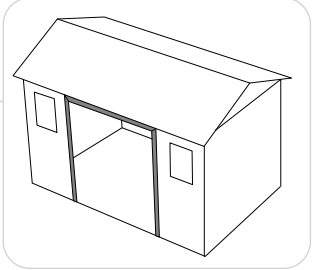

s13b x 1

17

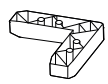

MoFDC (x2)

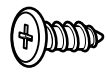

sc15 (x2)

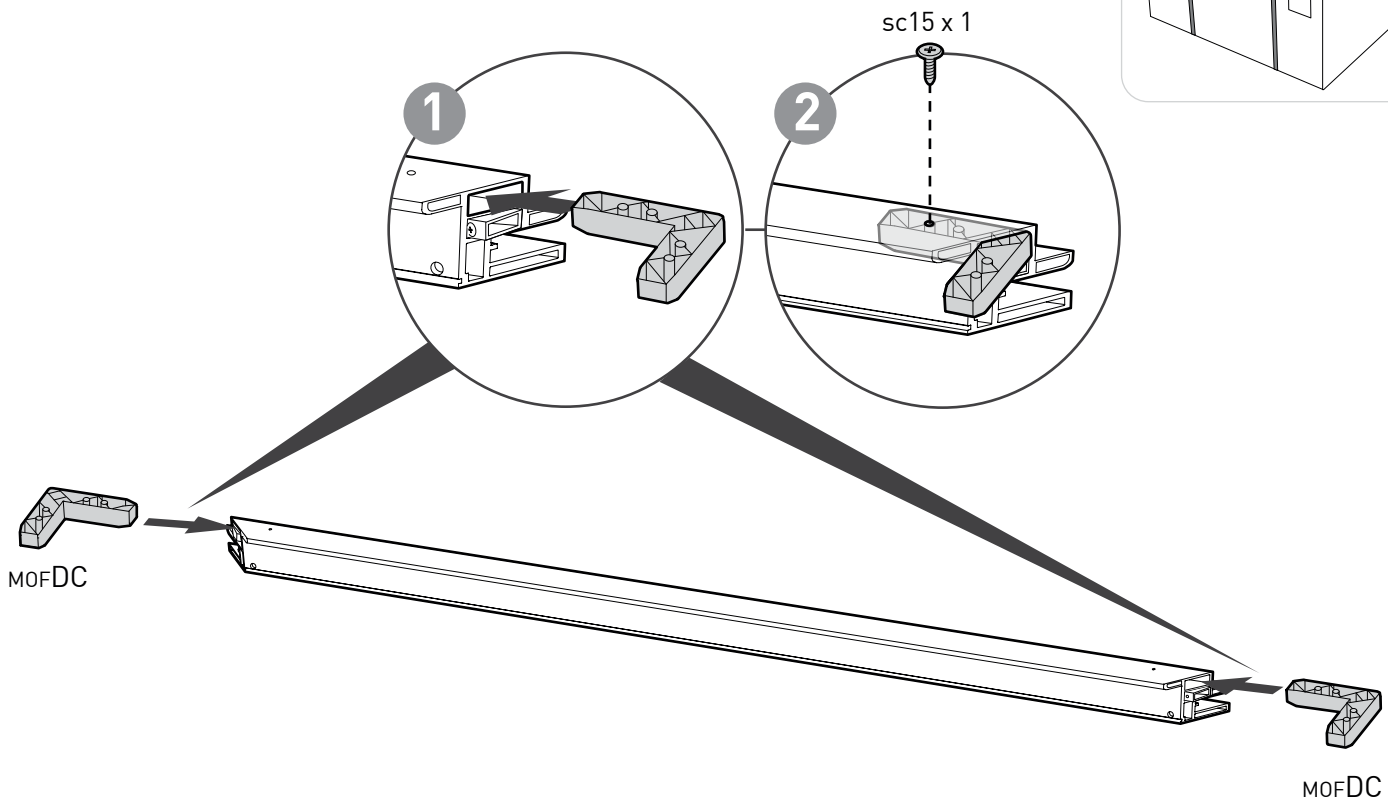
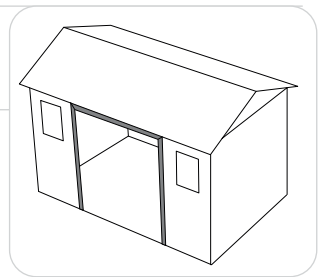

18



MoFDL (x1)



MoFDR (x1)

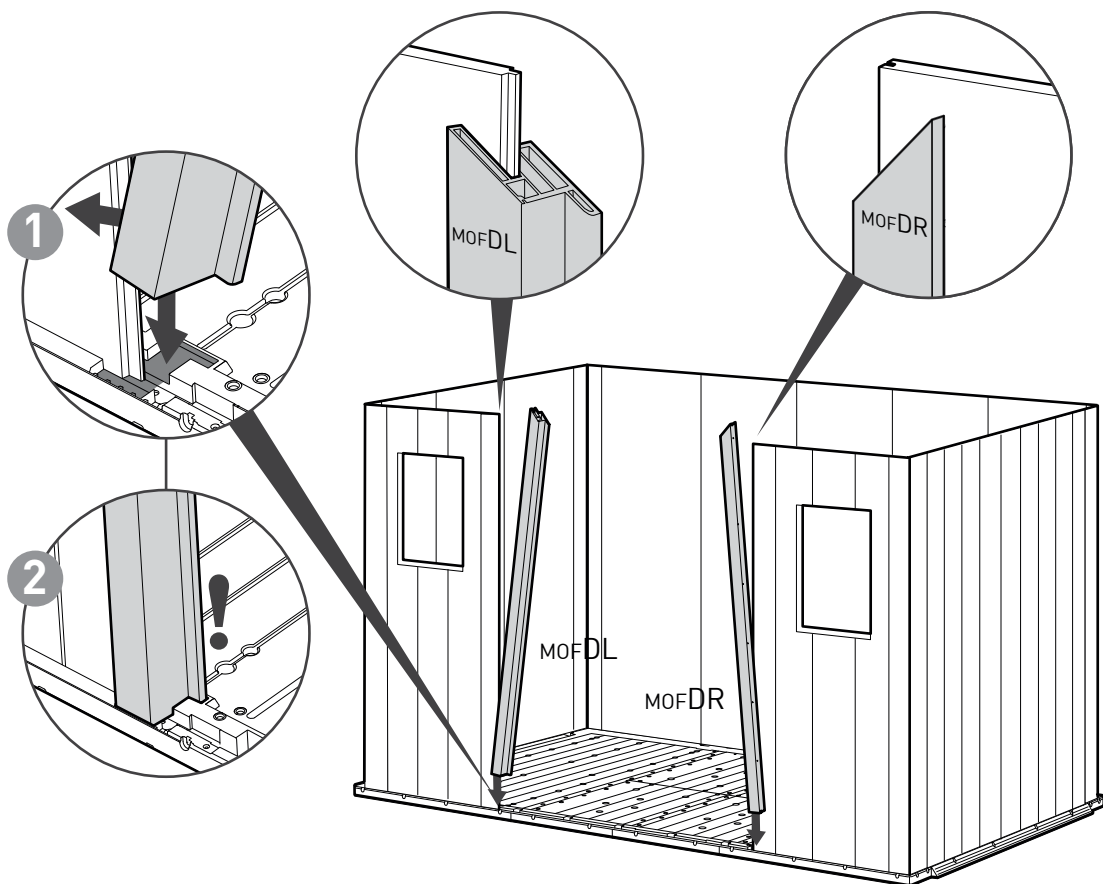
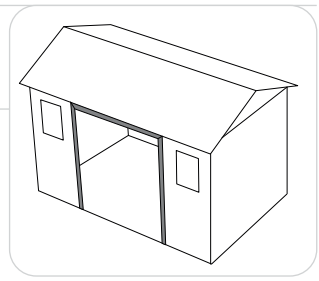

19

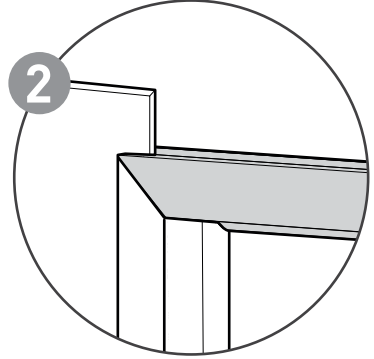
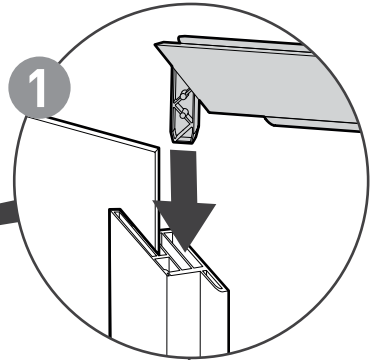
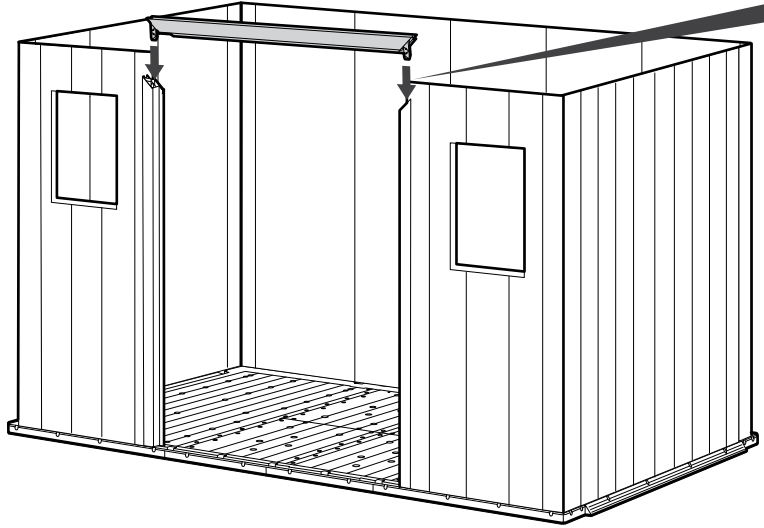
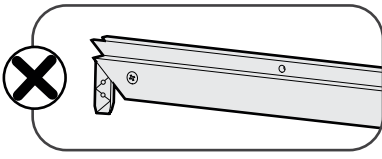
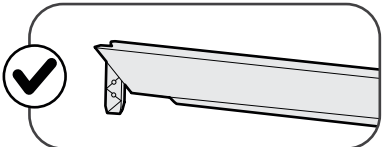
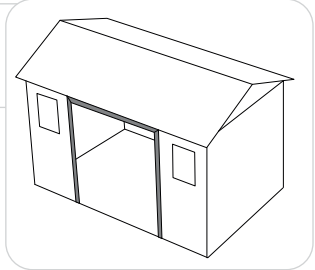

20

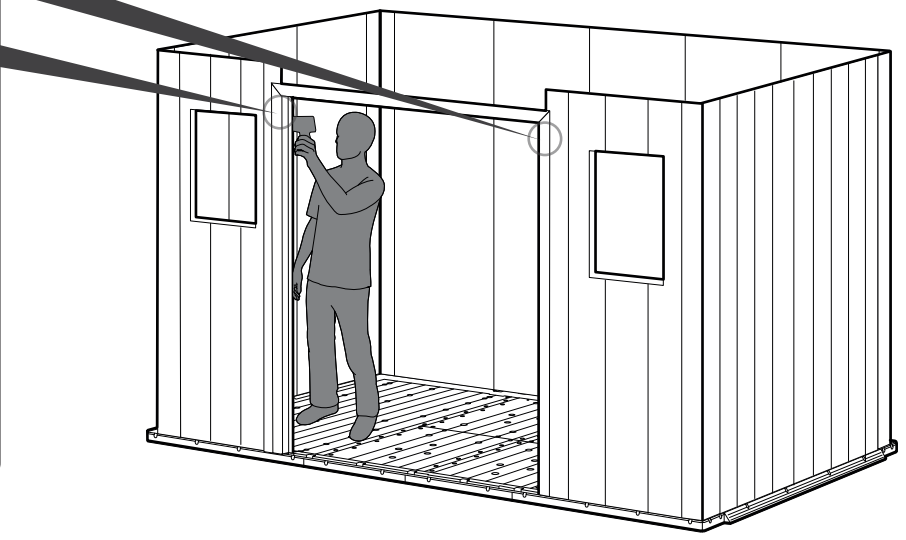
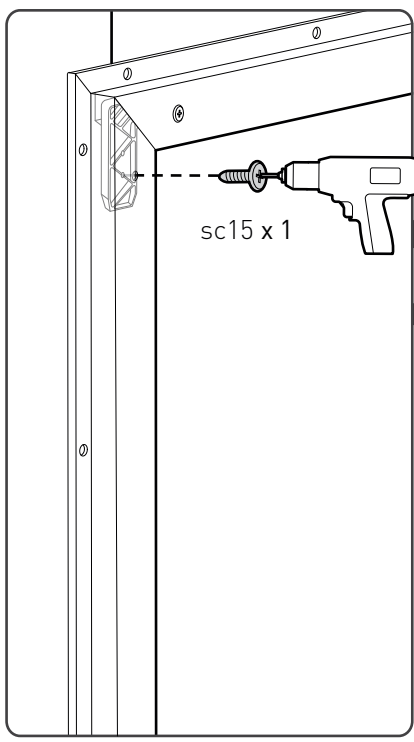
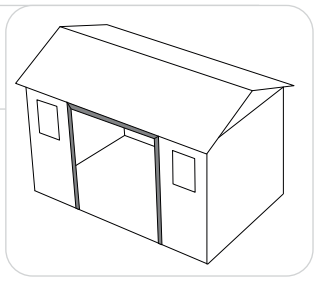

21



oLHC (x2)

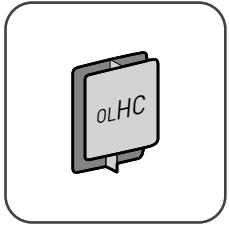
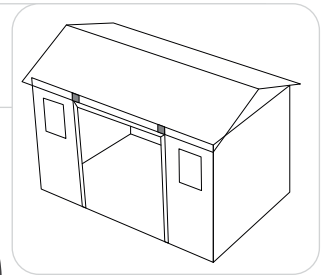

Wewnątrz

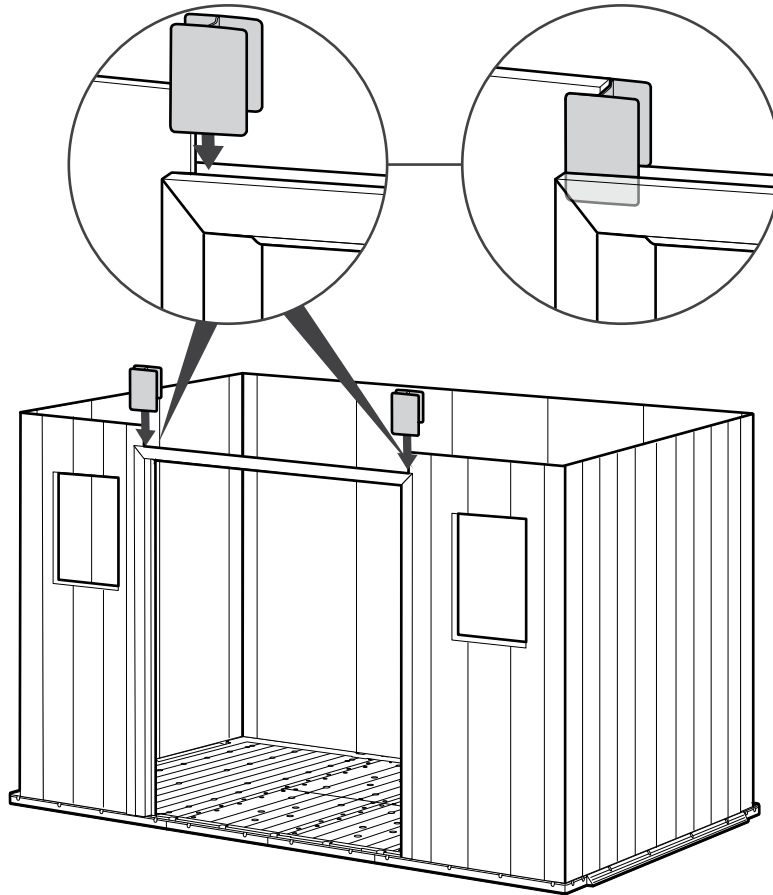

22

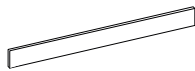

oLWT (x1)

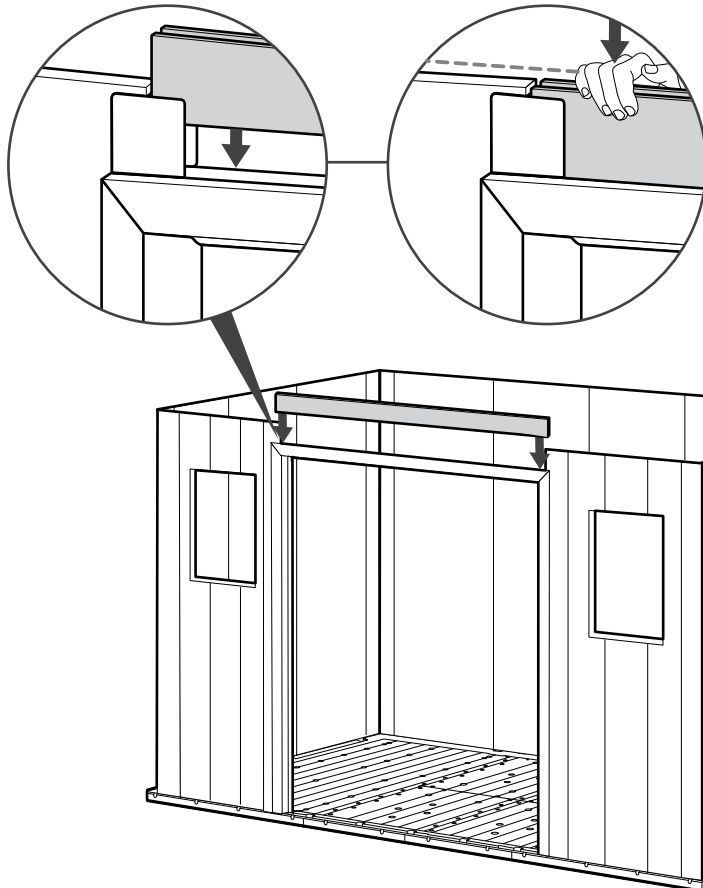
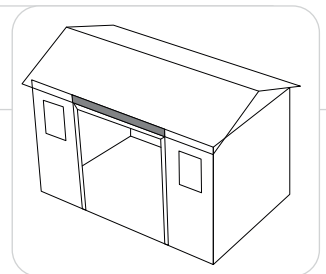



23



moMW (x2)



sc15 (x2)

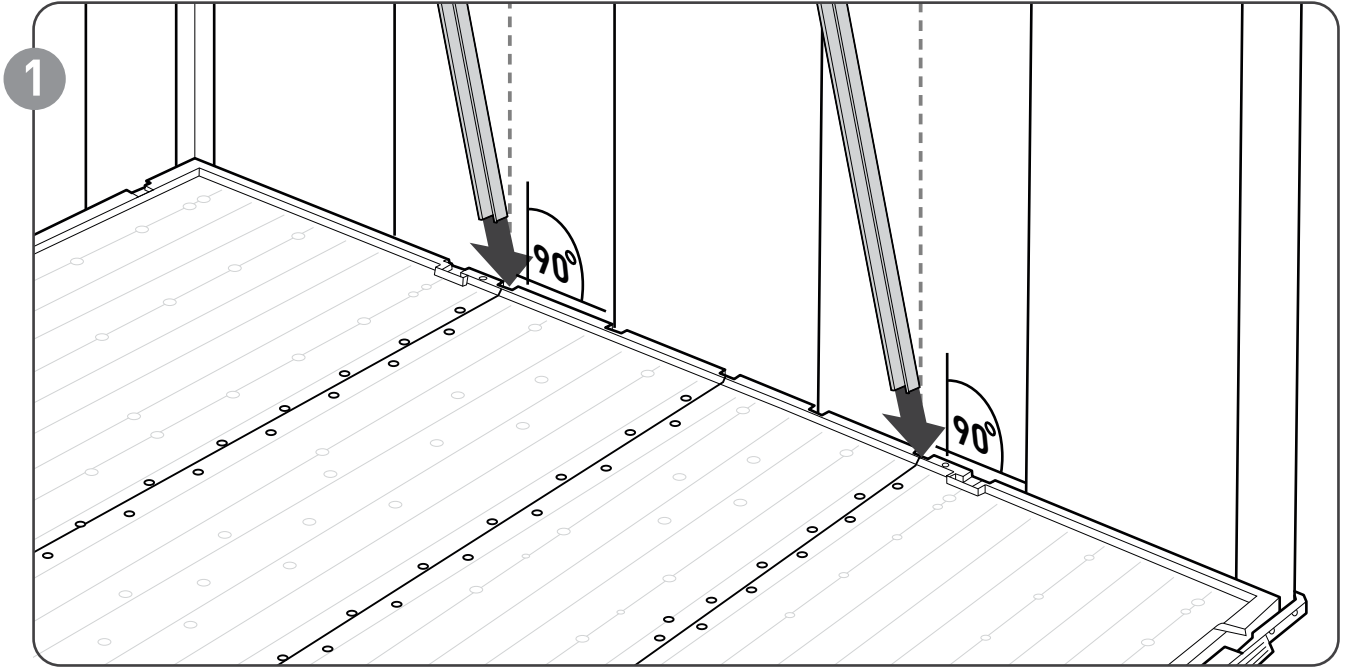
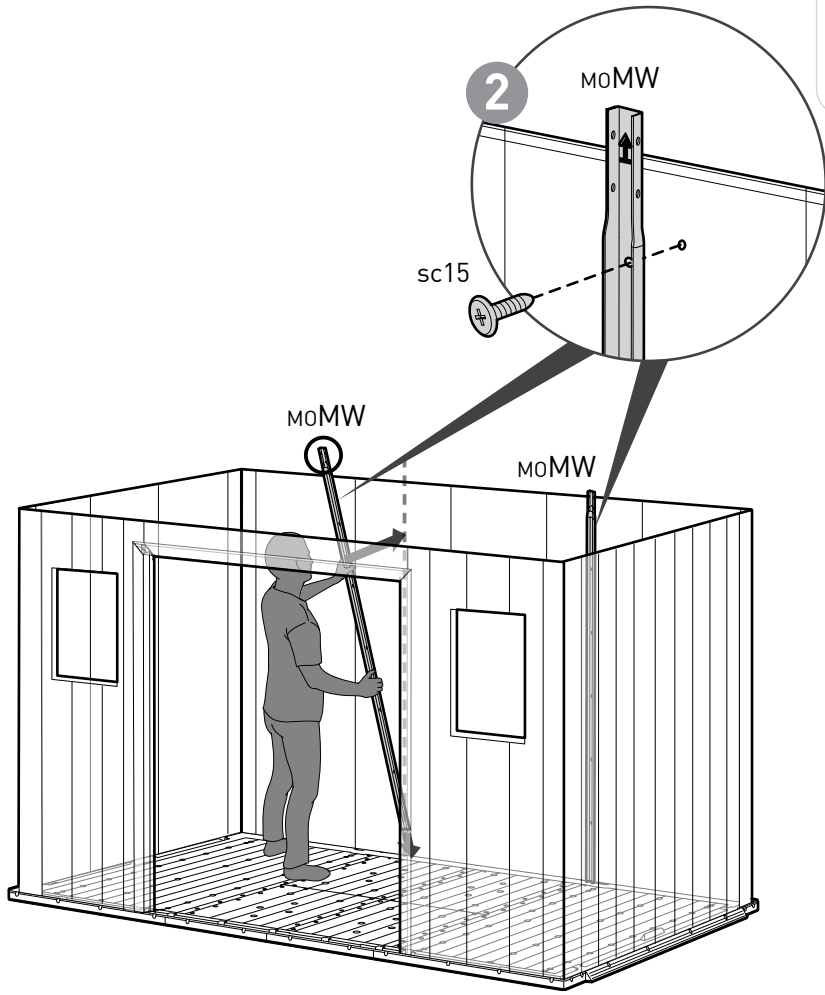
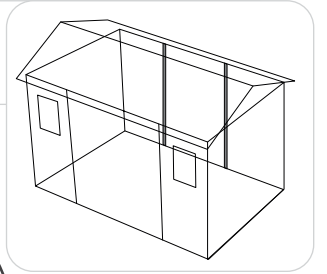

24

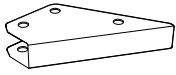

FNME (x2)



sc8 (x2)



scn8 (x2)

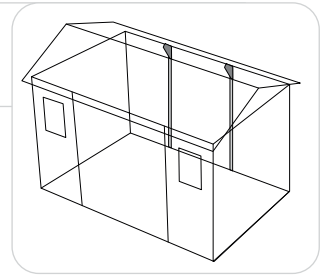
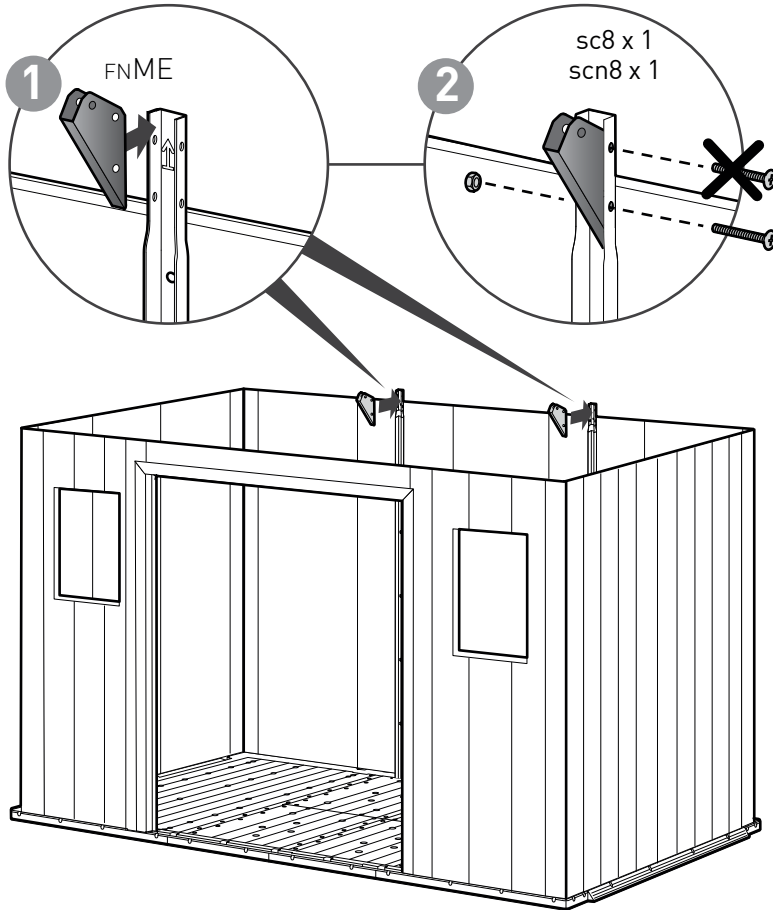

25



moMC (x2)

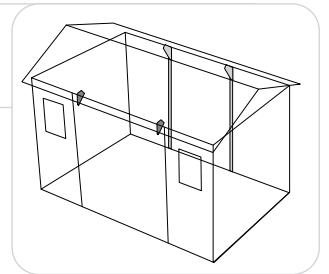
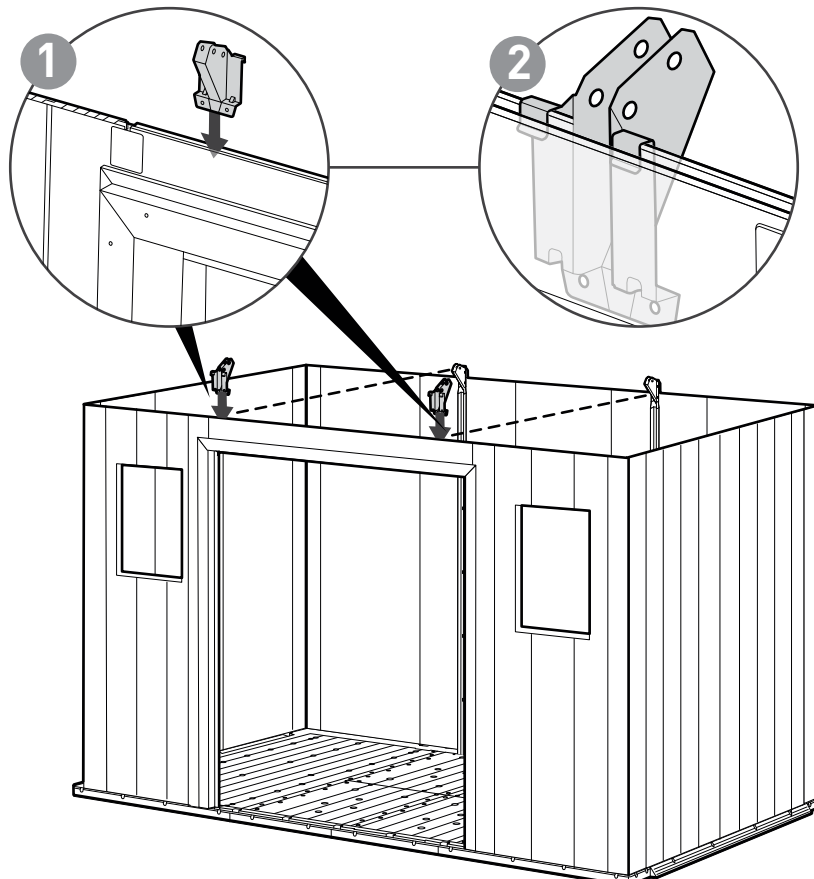

26

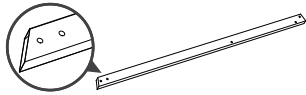

m0MG (x4)

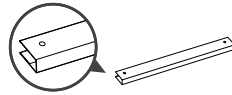

m0MH (x2)



m0MA (x2)



sc8 (x12)



scn8 (x12)

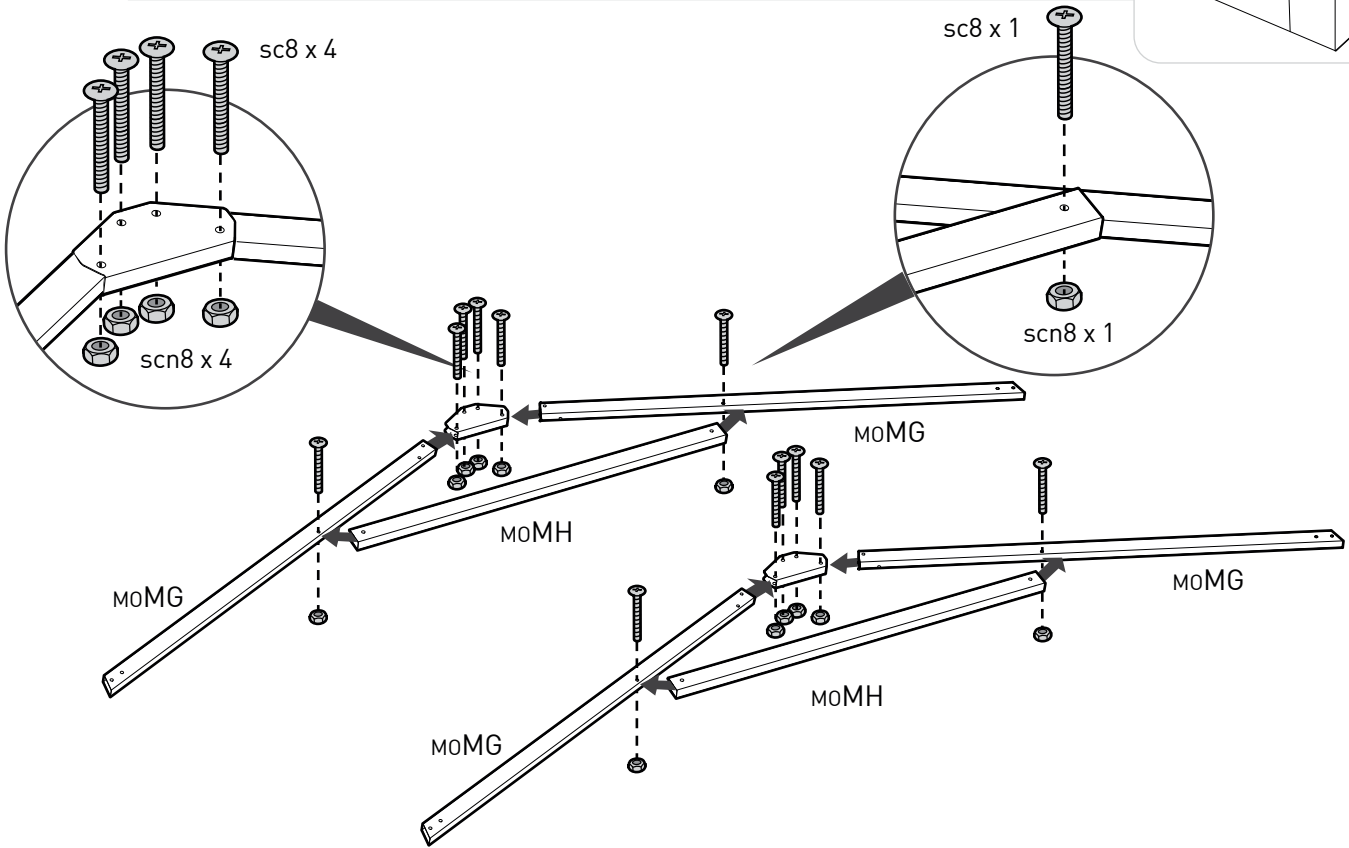
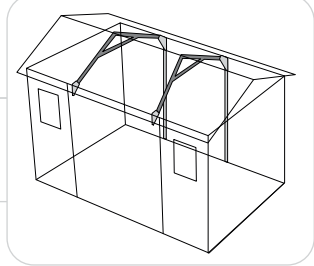

27

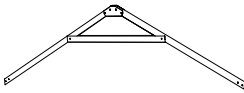

sc8 (x8)



scn8 (x8)

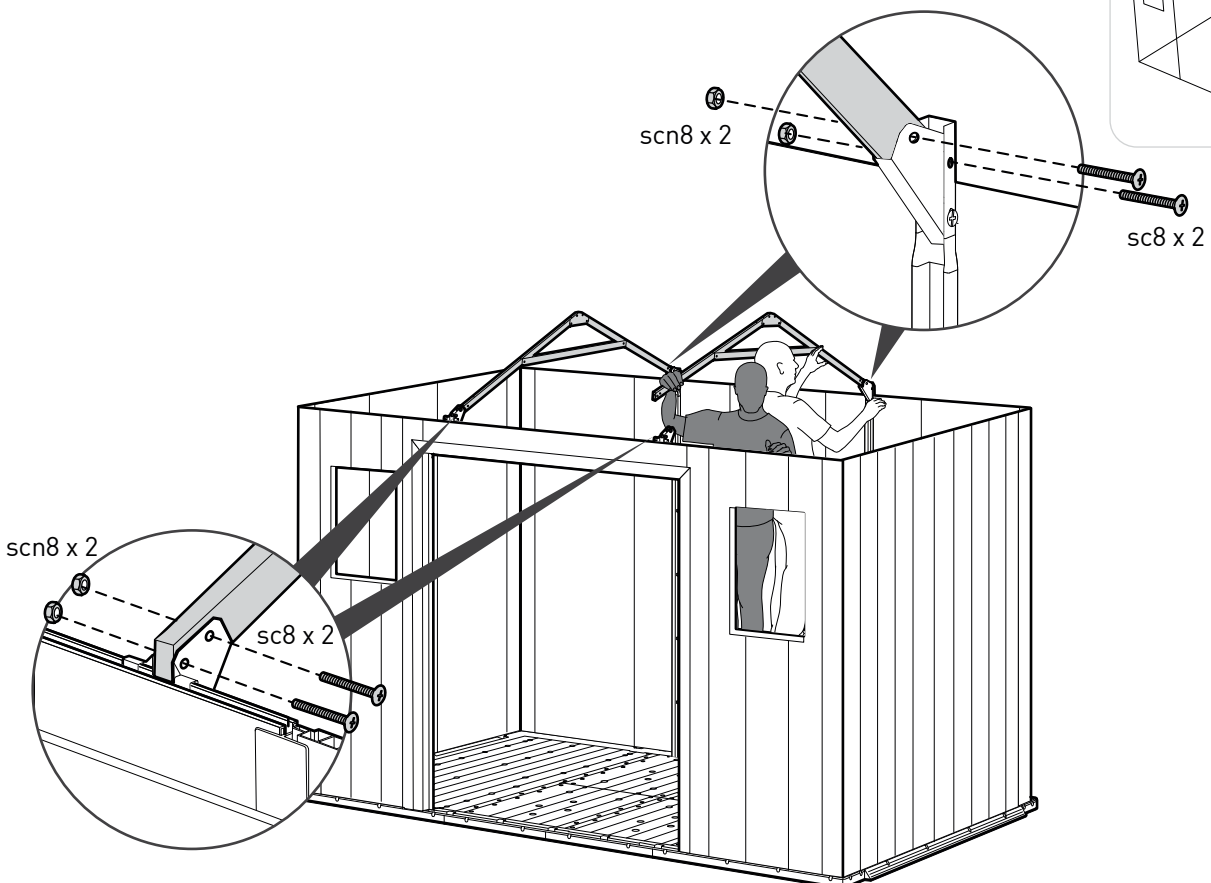
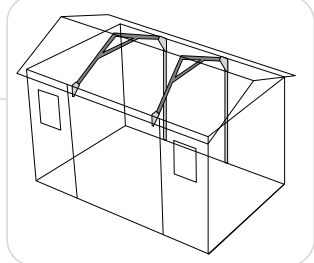

28

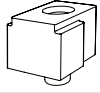

FNCH (x2)

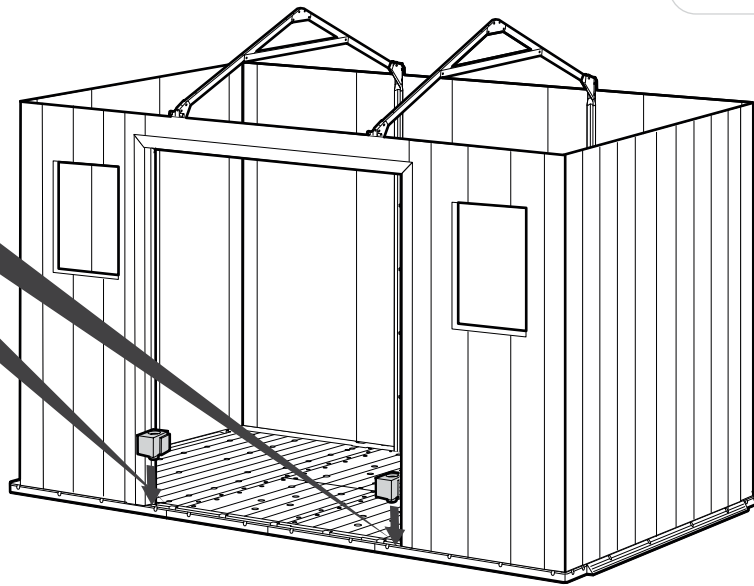
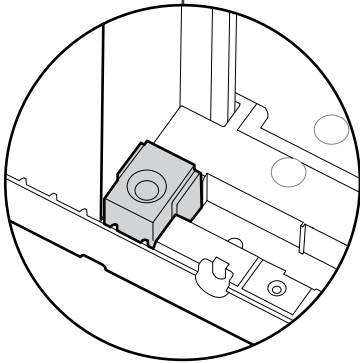
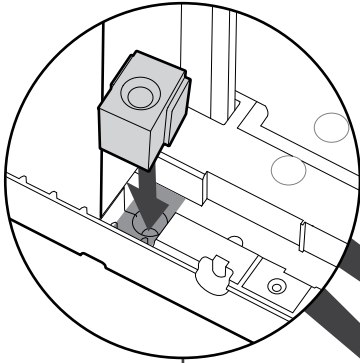
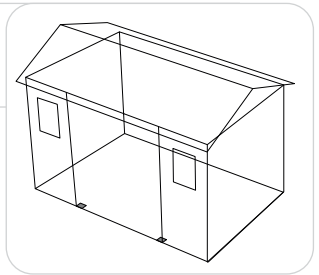

29

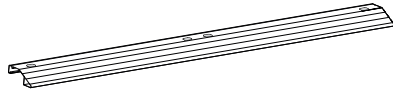

moMT (x1)



sc15 (x4)

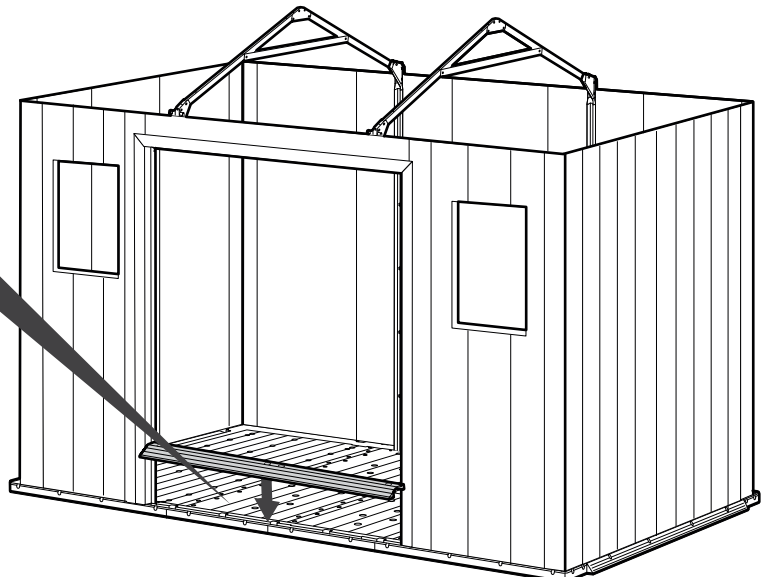
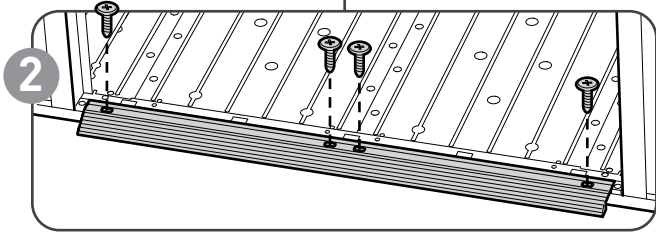
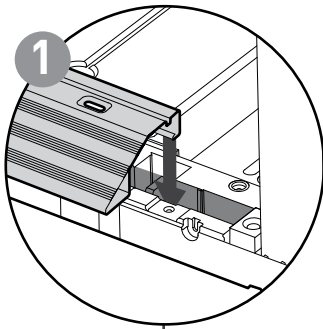
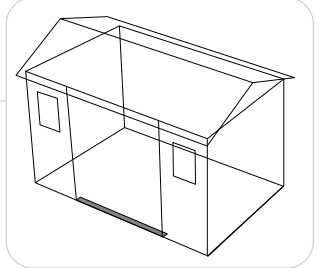

30

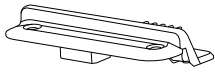

oLFS (x1)



sc15 (x4)

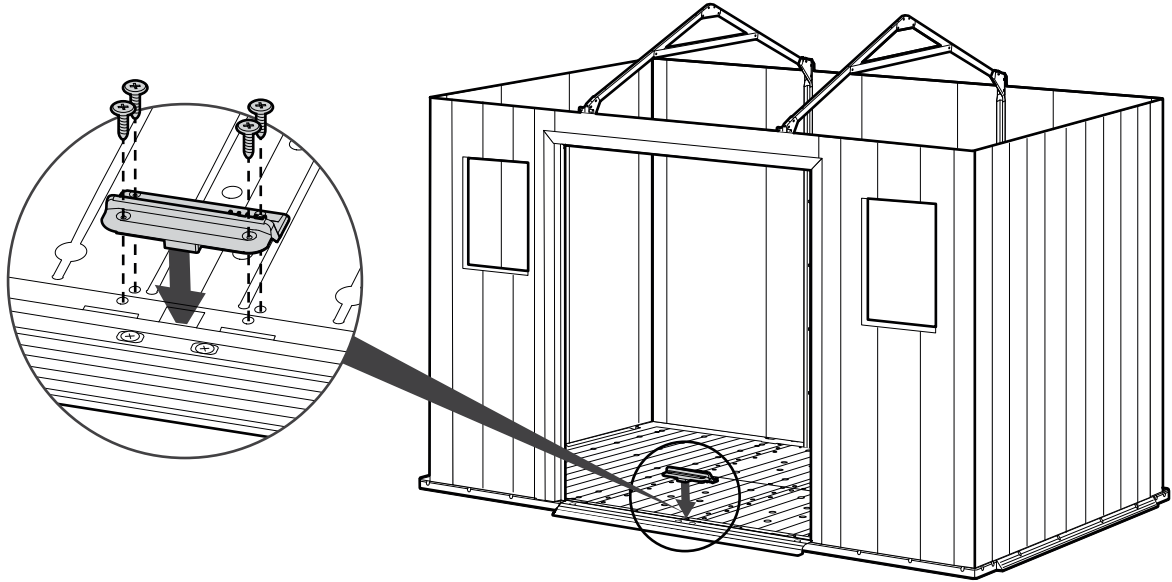
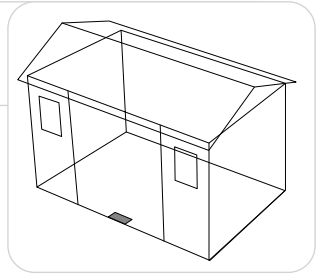

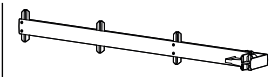

oLCB (x4)

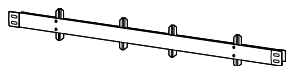

oLCM (x2)

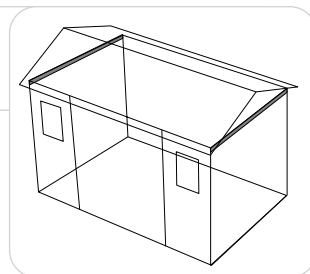

Wewnątrz

1

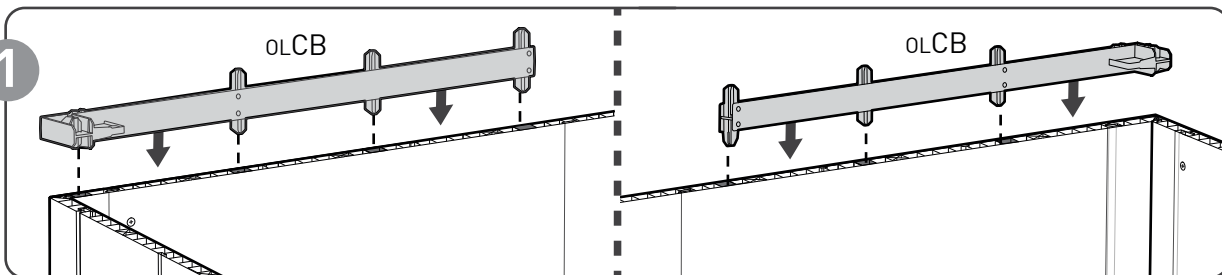

2

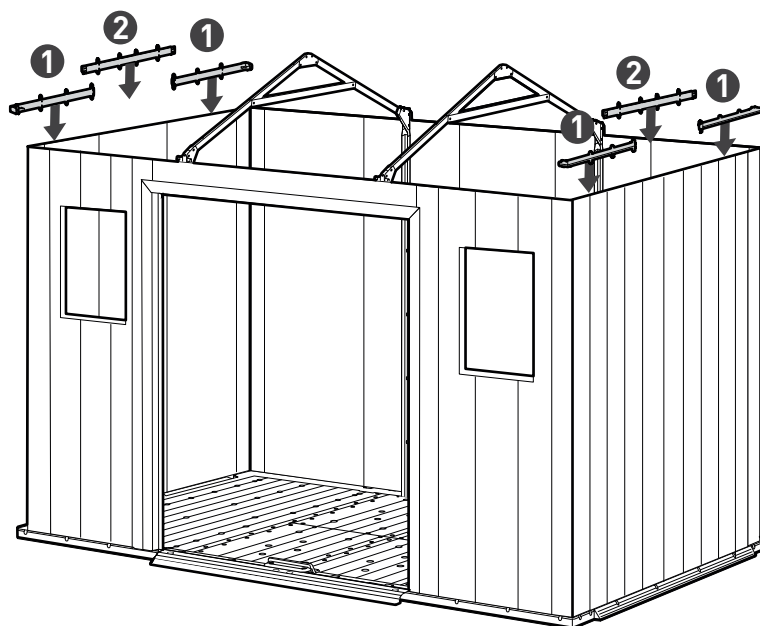
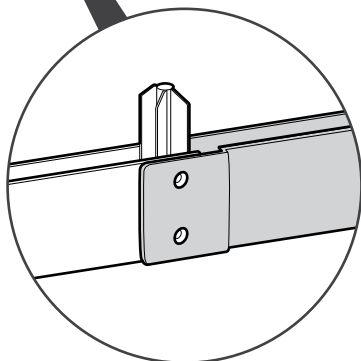
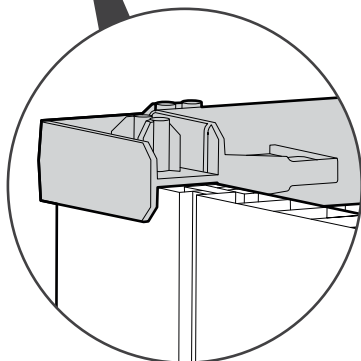
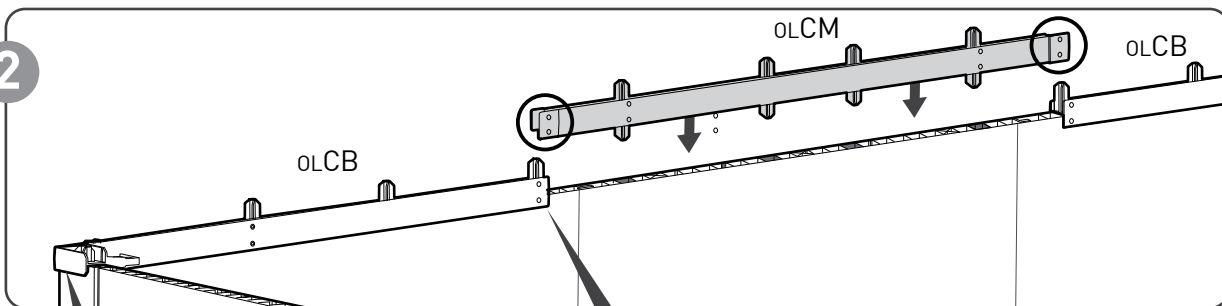

32

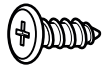



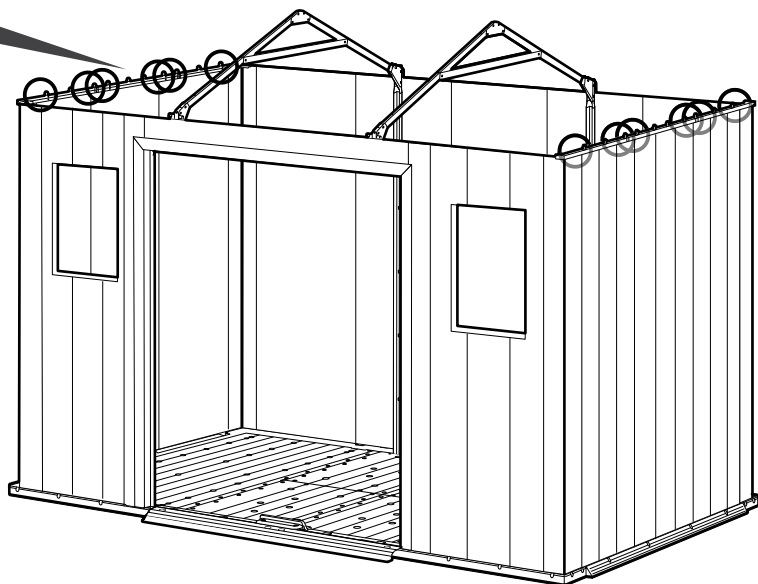
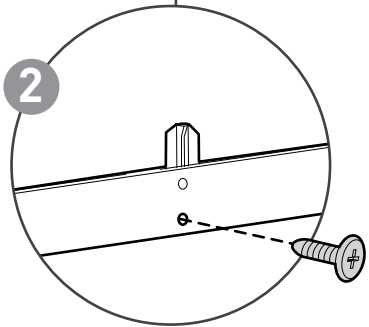
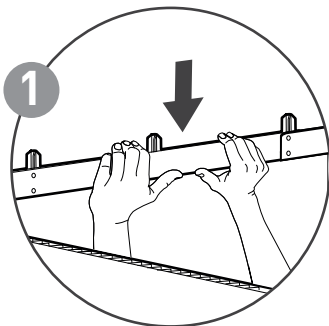
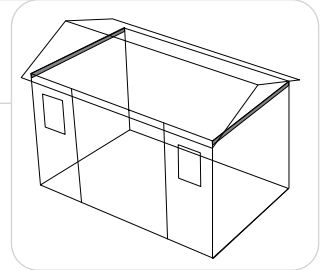



sc15 (x12)

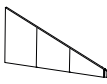

# MONTAŻ DACHU

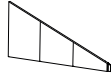
33

- 
OLZ1 (x1)
- 
OLZ2 (x1)
- 
OLZ3 (x1)
- 
OLZ4 (x1)
- 
OLZ5 (x1)
- 
OLZ6 (x1)
- 
s13b (x8)

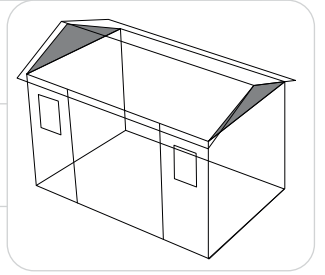

1

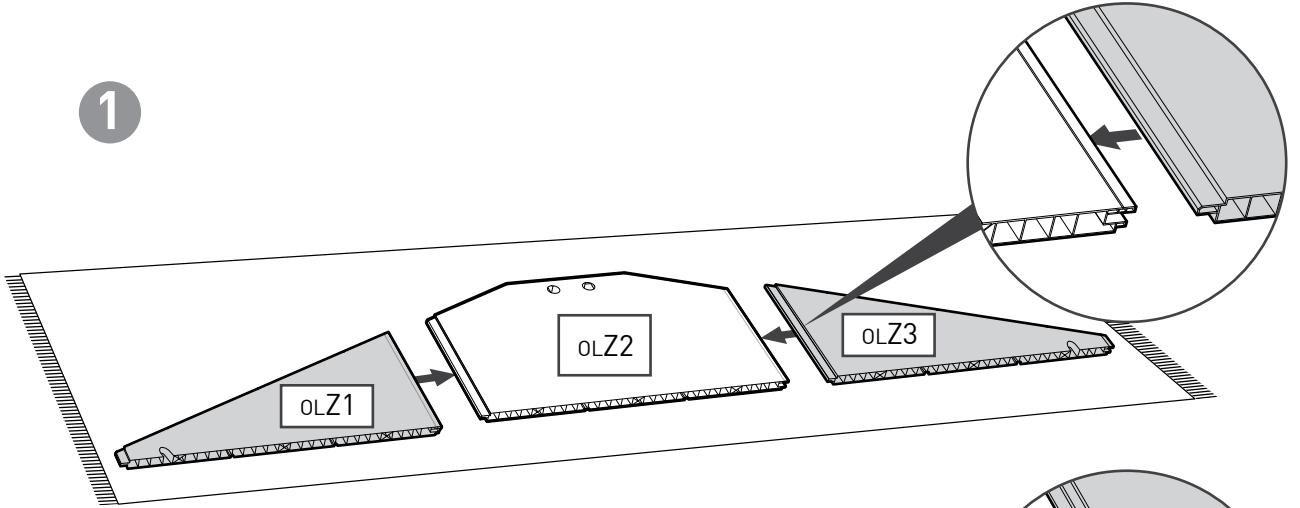

2

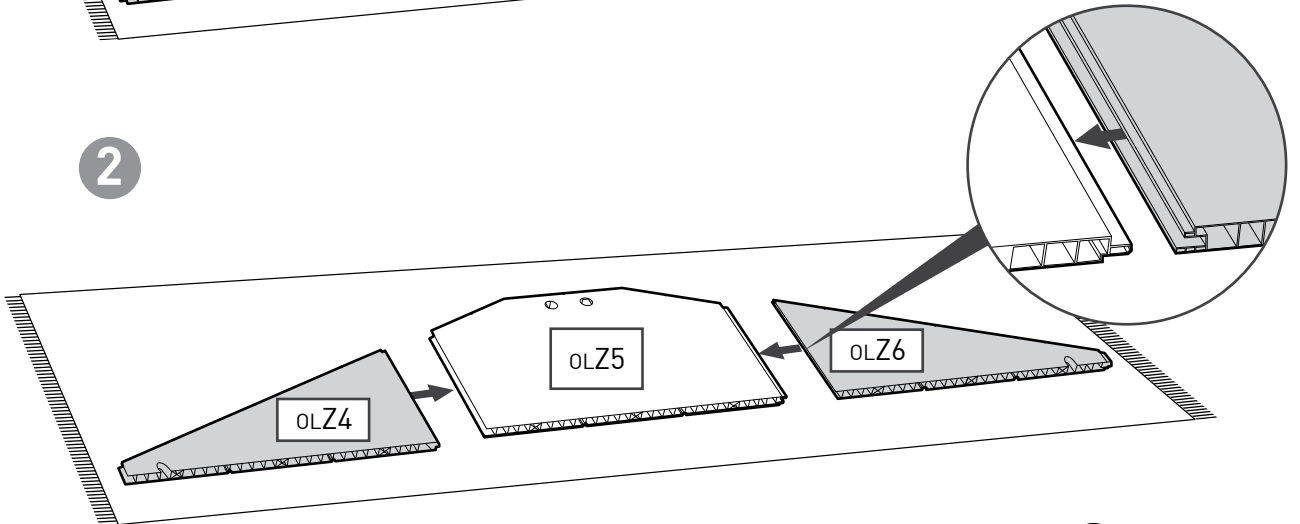

3

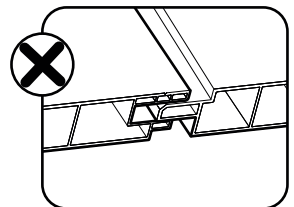
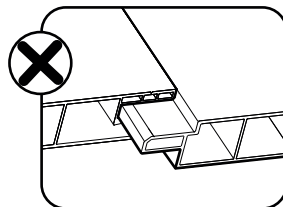
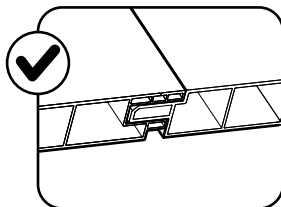
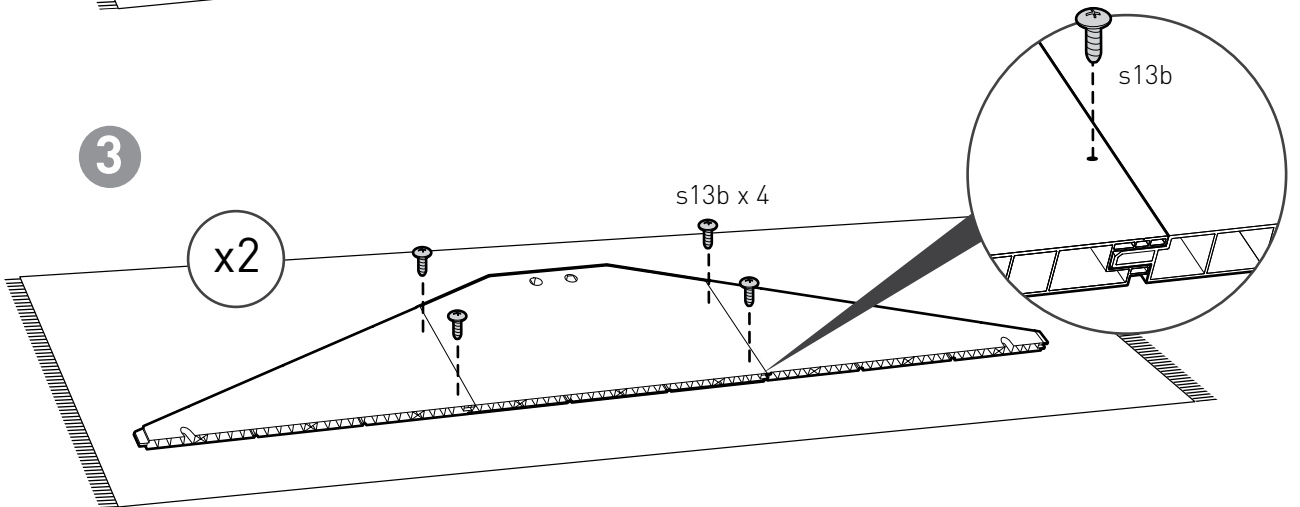



34

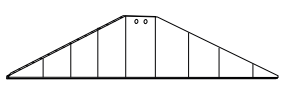

(x2)



moAK (x2)

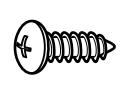

s13b (x2)

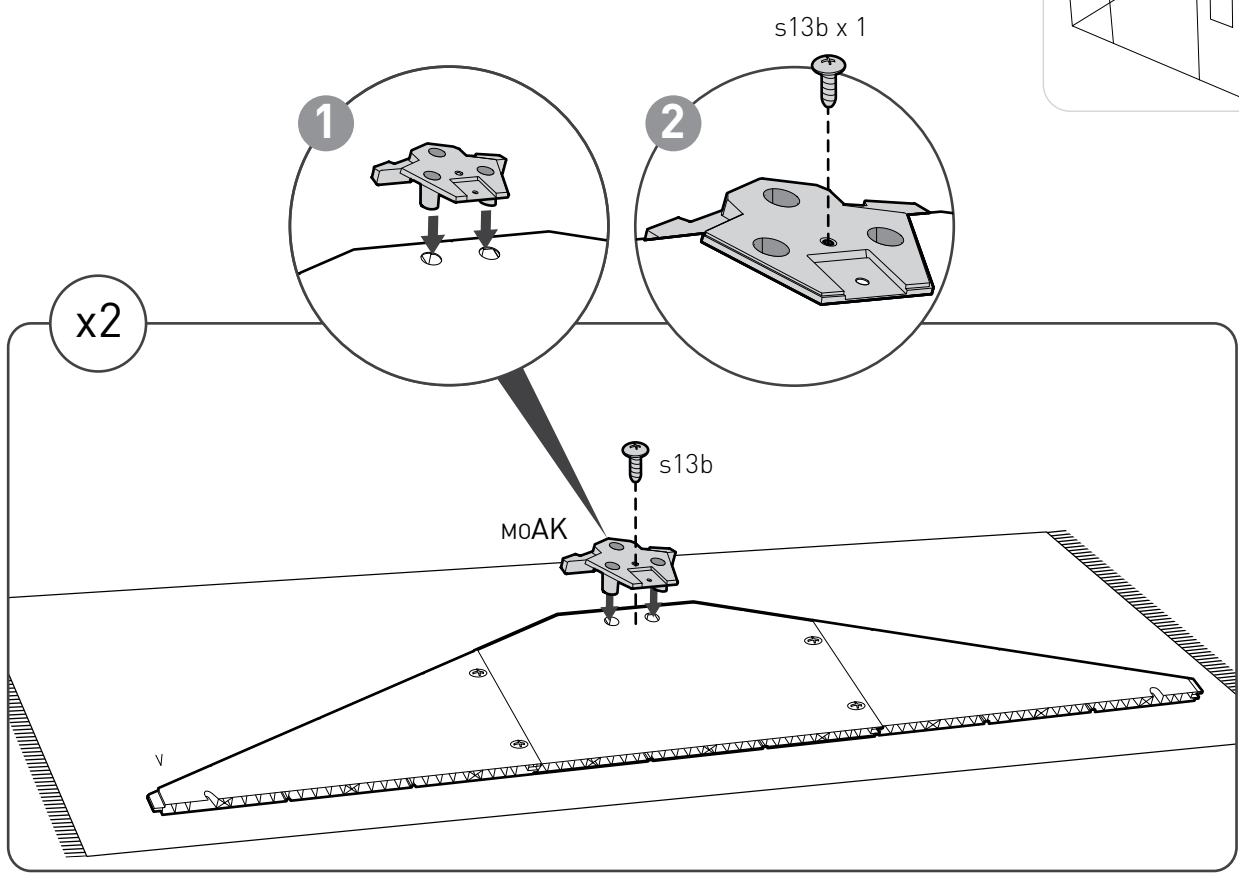
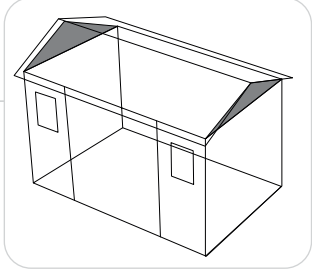

35

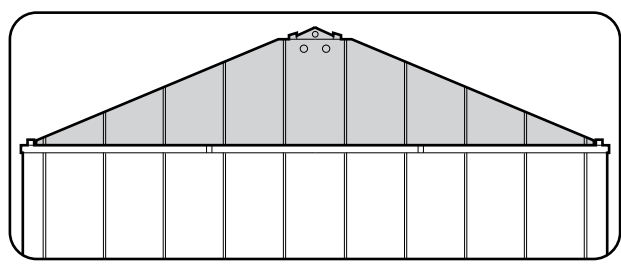
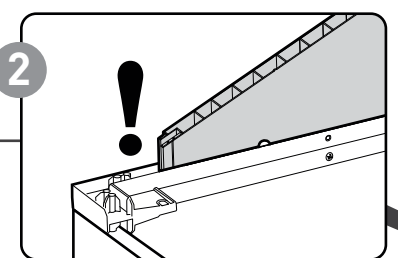
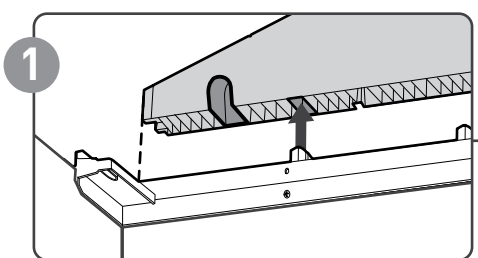
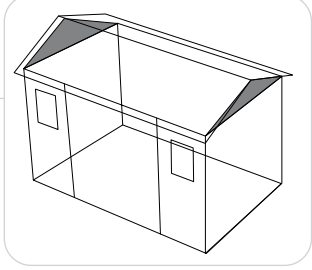
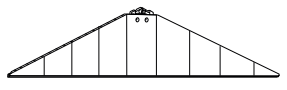

Na zewnątrz

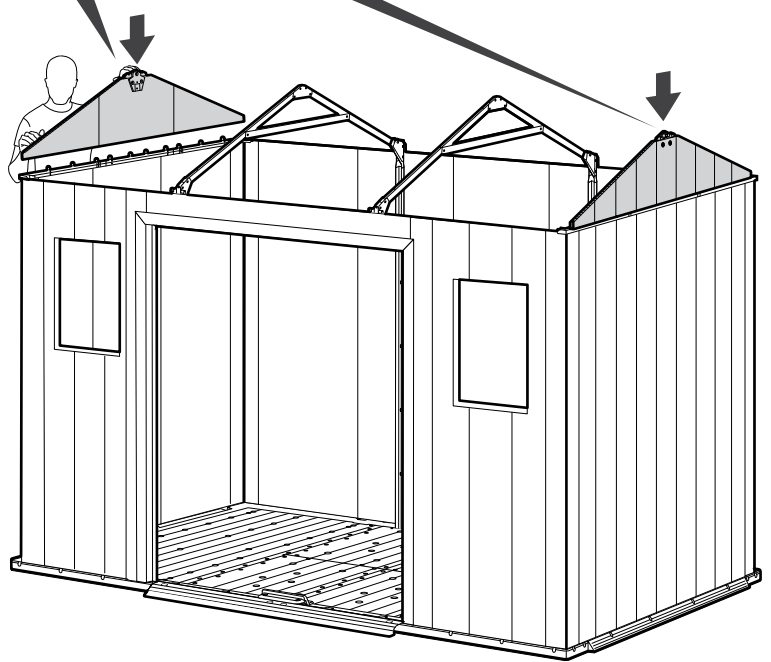

36



moMW (x2)

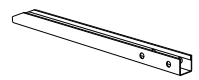

moME (x2)

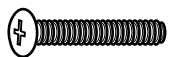

sc8 (x4)



scn8 (x4)

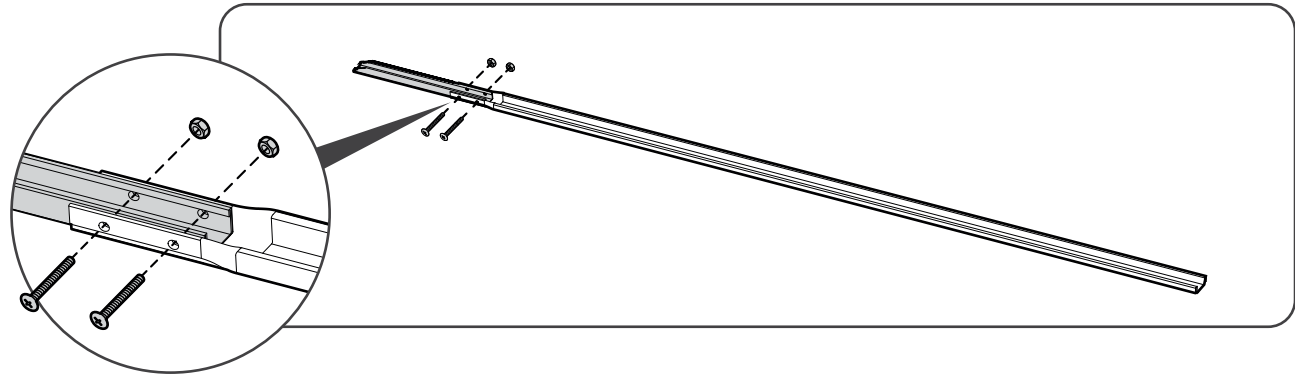
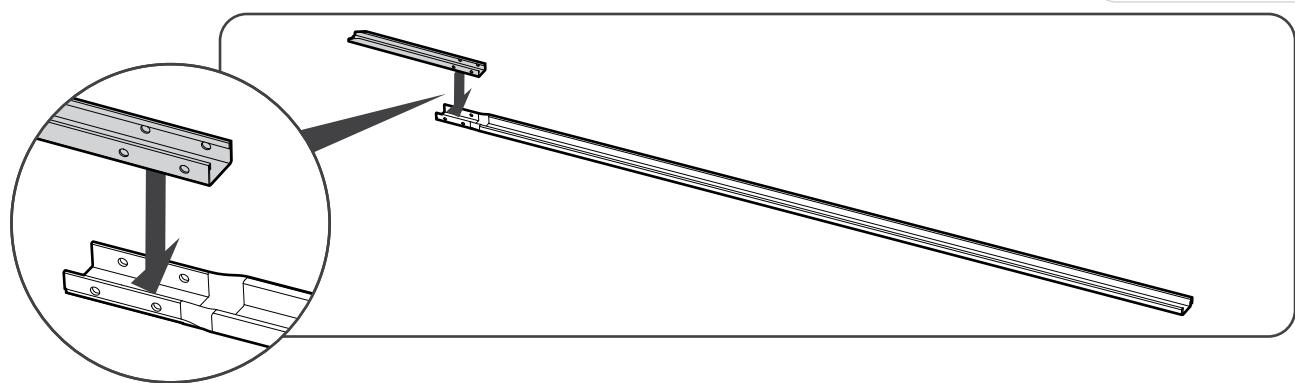
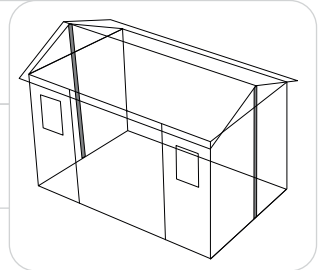

37



moMW + moME (x2)

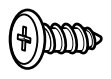

sc15 (x16)

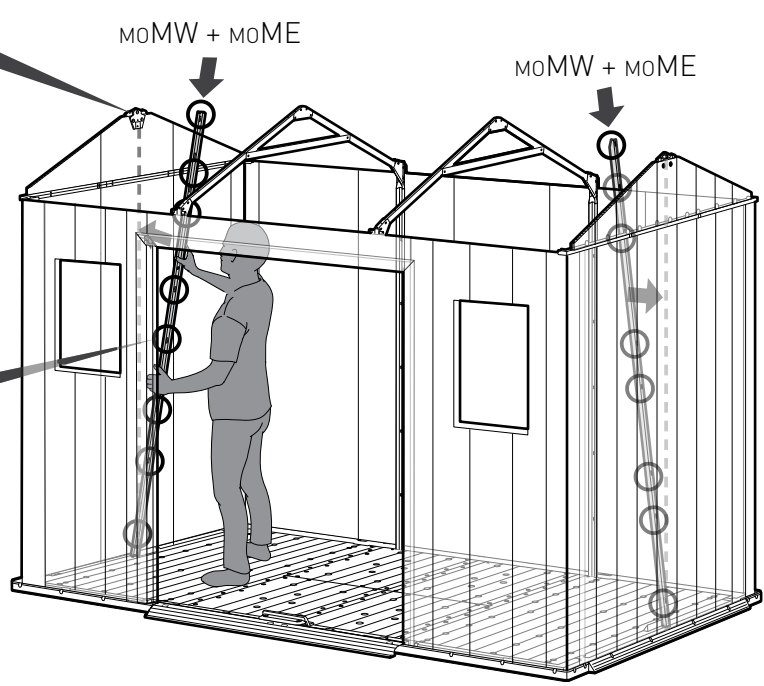
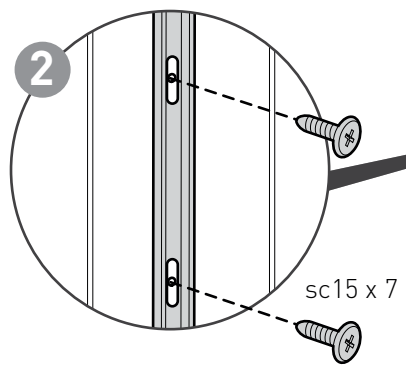
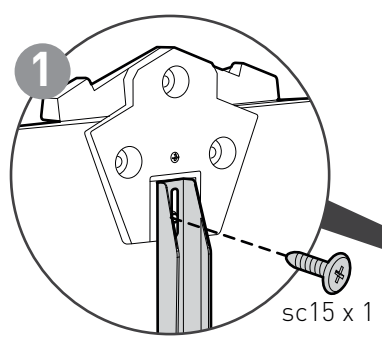
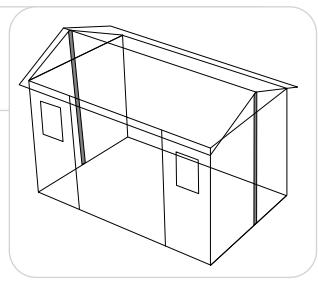



MOFTD (x2)

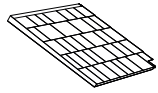

MOFTU (x2)

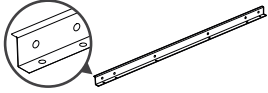

MOFM7 (x4)



sc15 (x20)

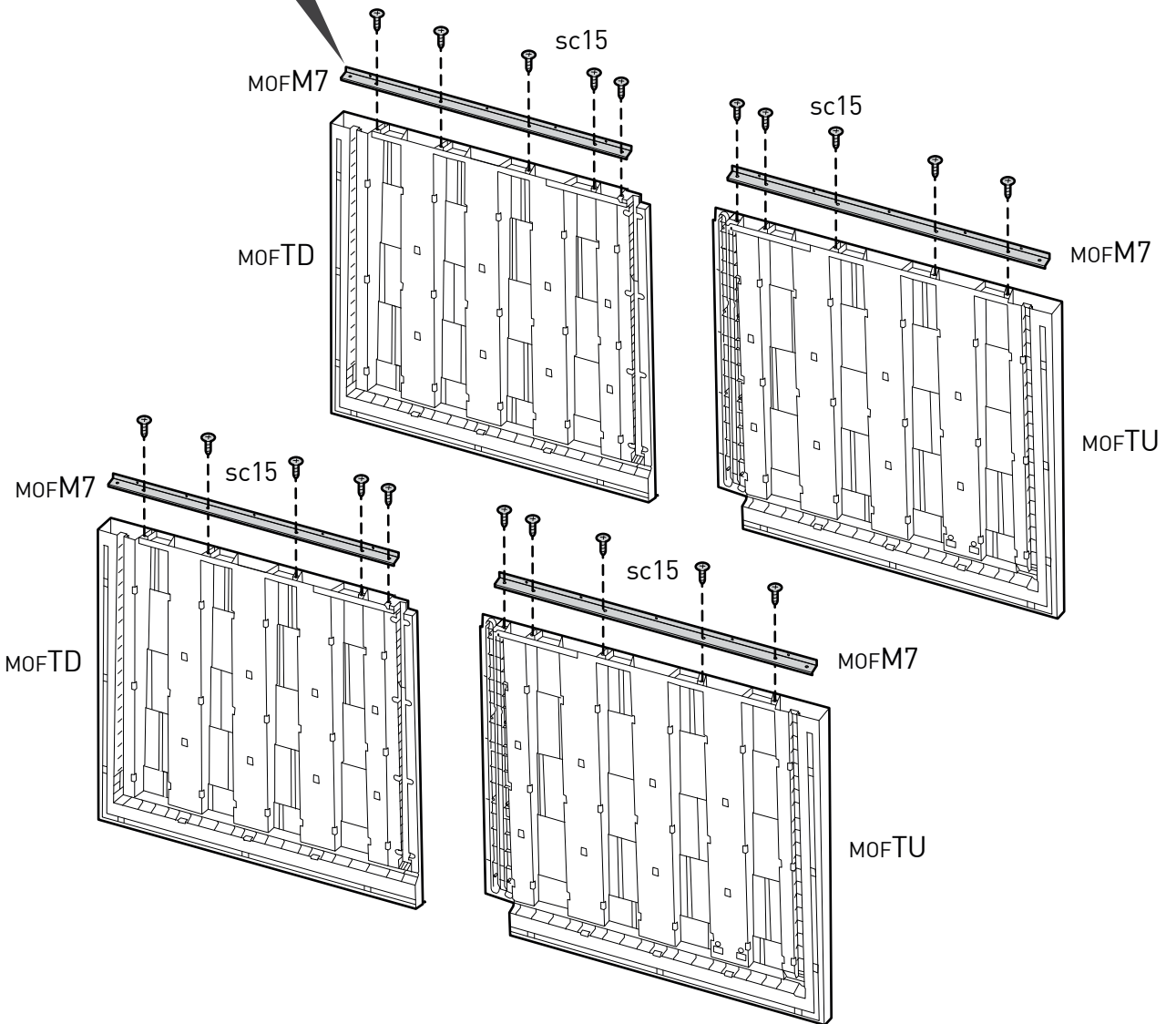
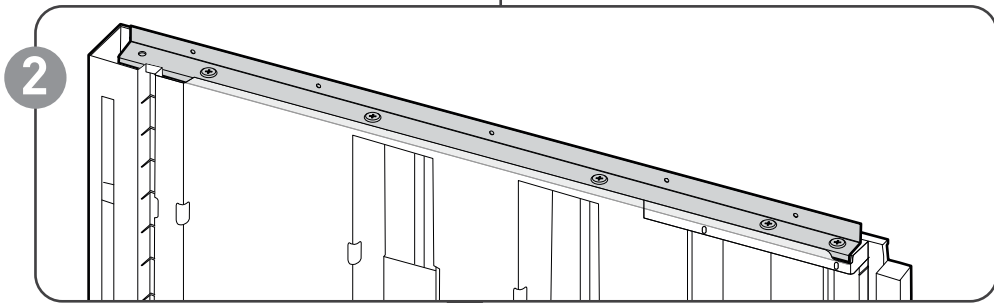
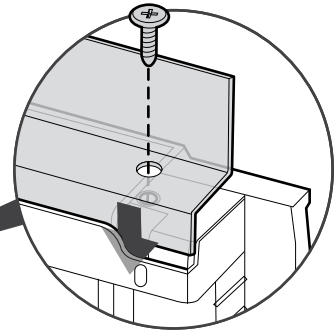
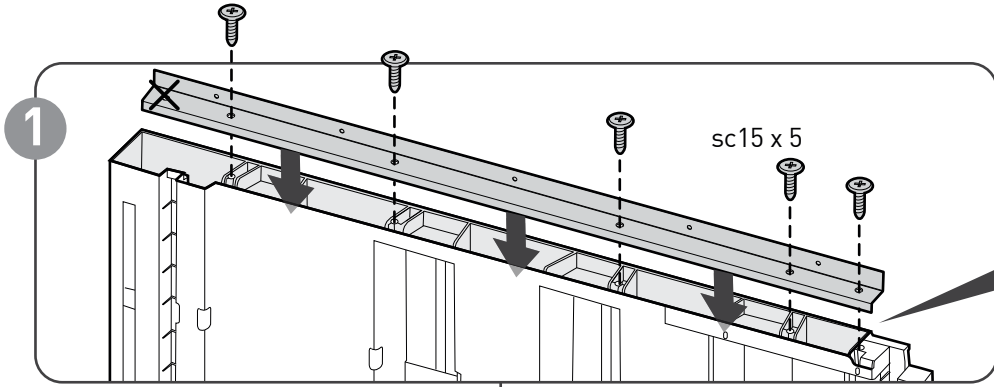
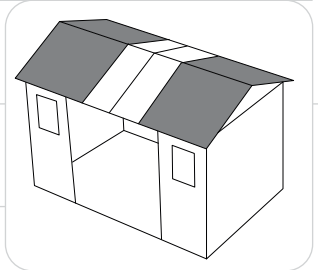

39



MOFT9 (x4)

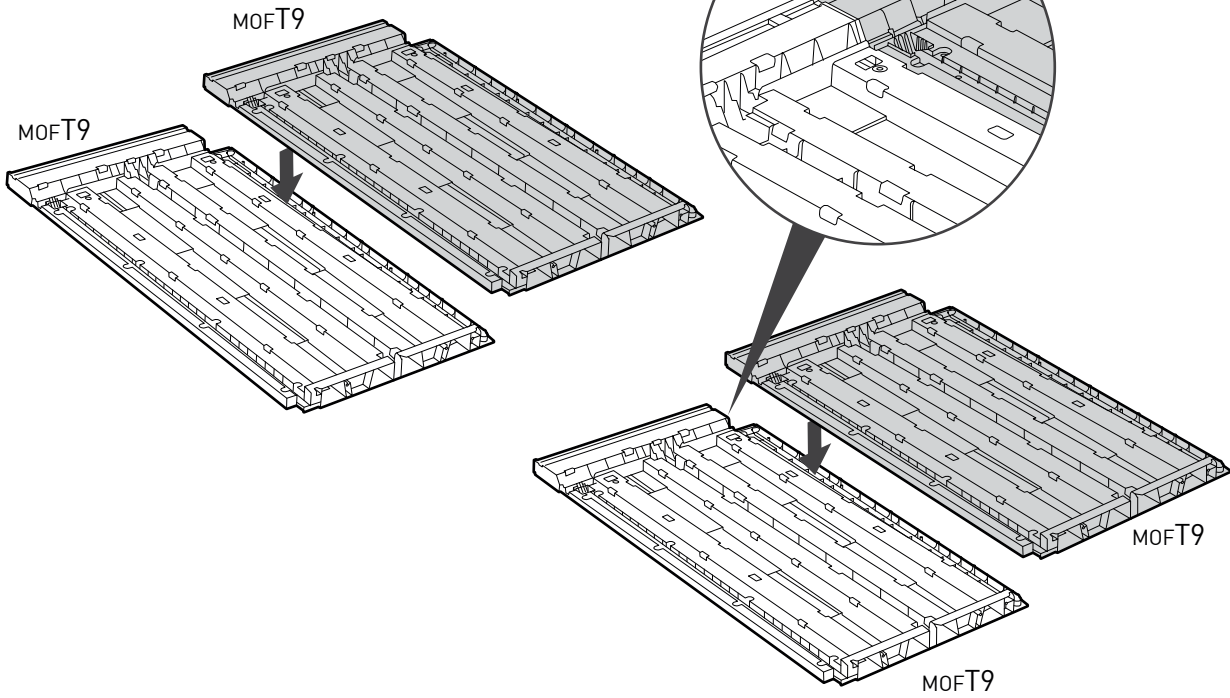
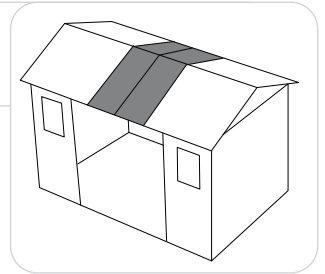

40



(x2)

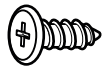

sc15 (x16)

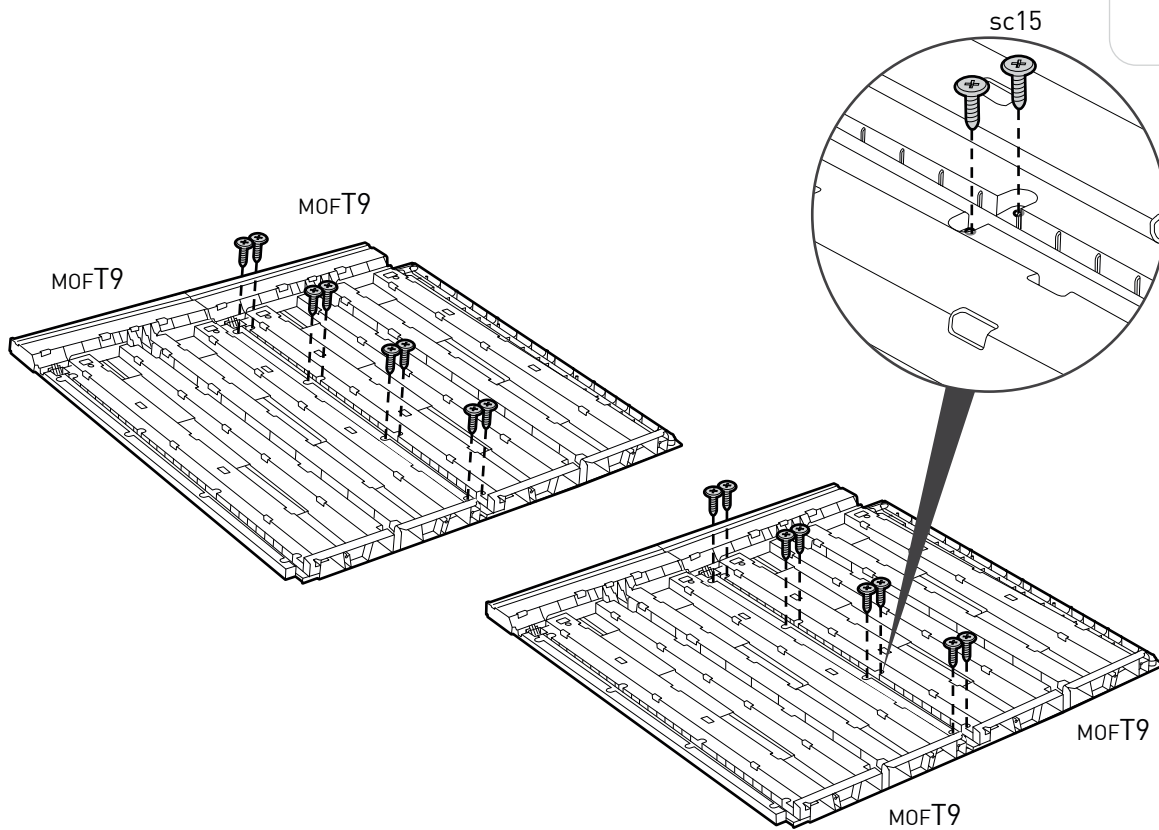
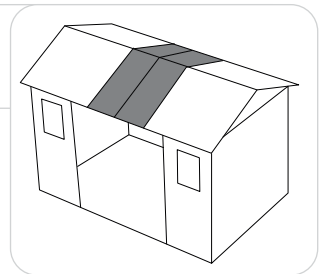

41

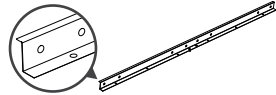

moM11 (x2)

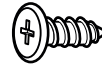

sc15 (x16)

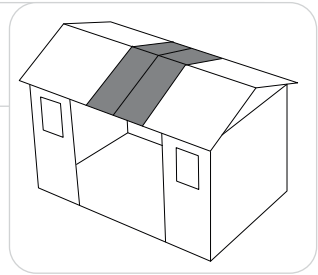

1

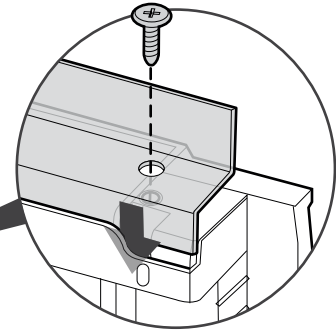
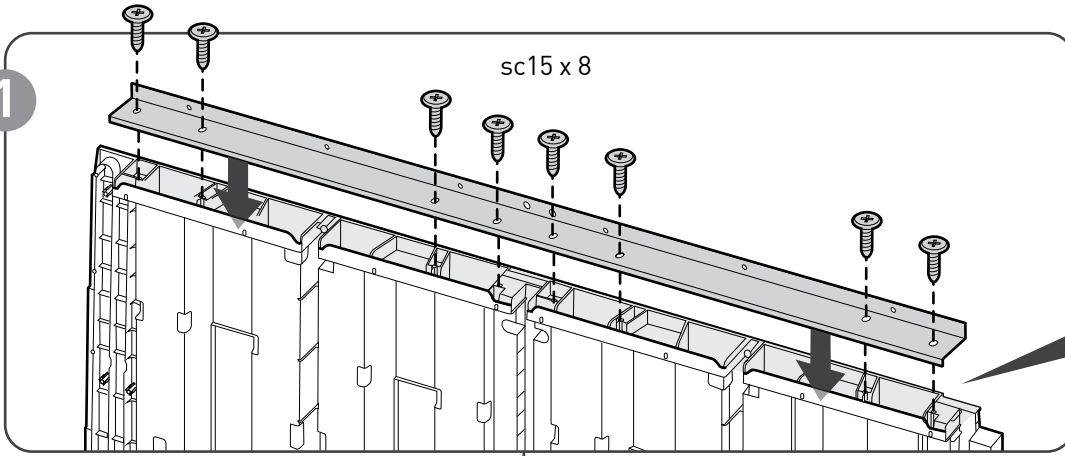

2

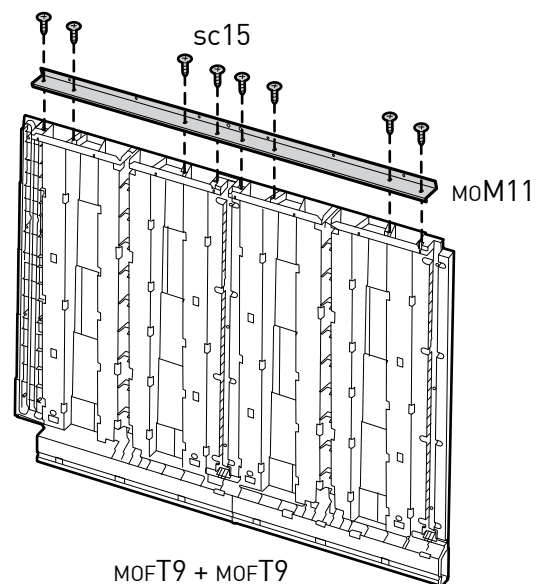
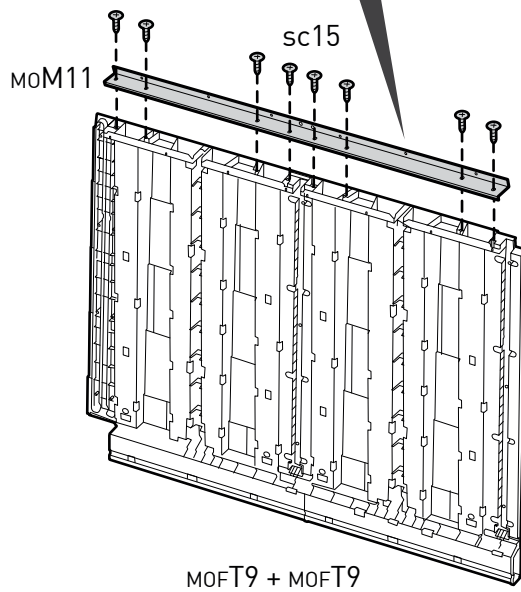
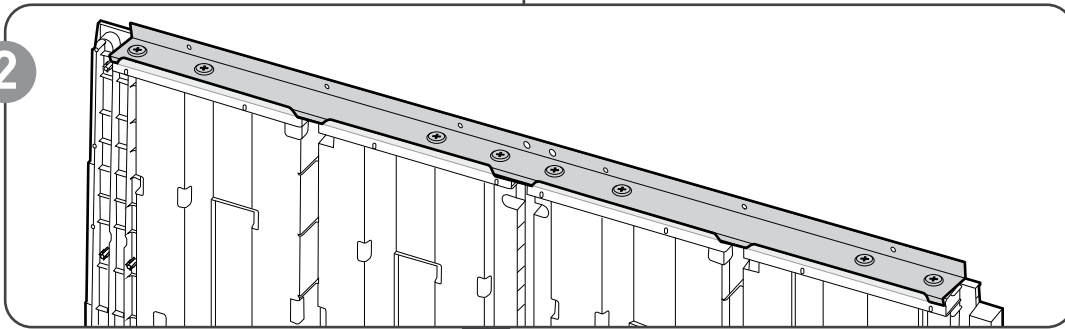

42



MOFTD (x1)

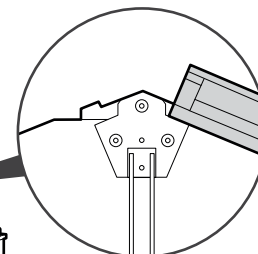
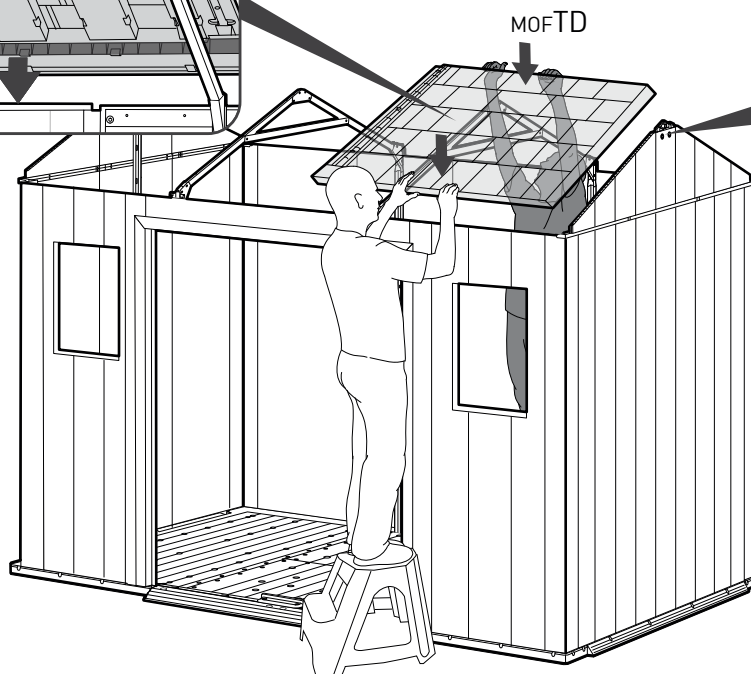
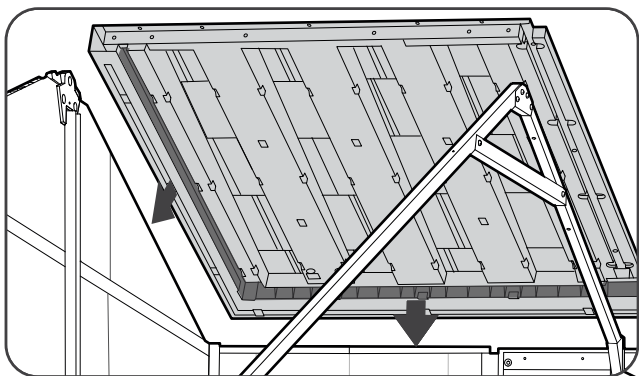
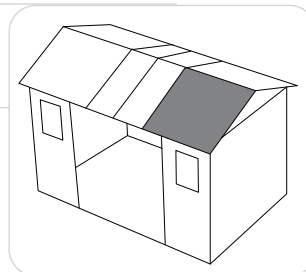

43



sc15 (x1)

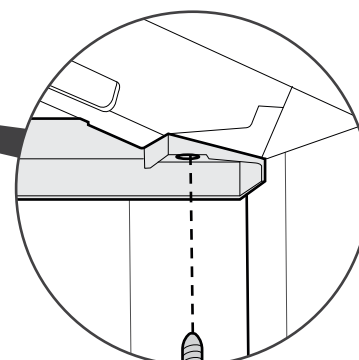
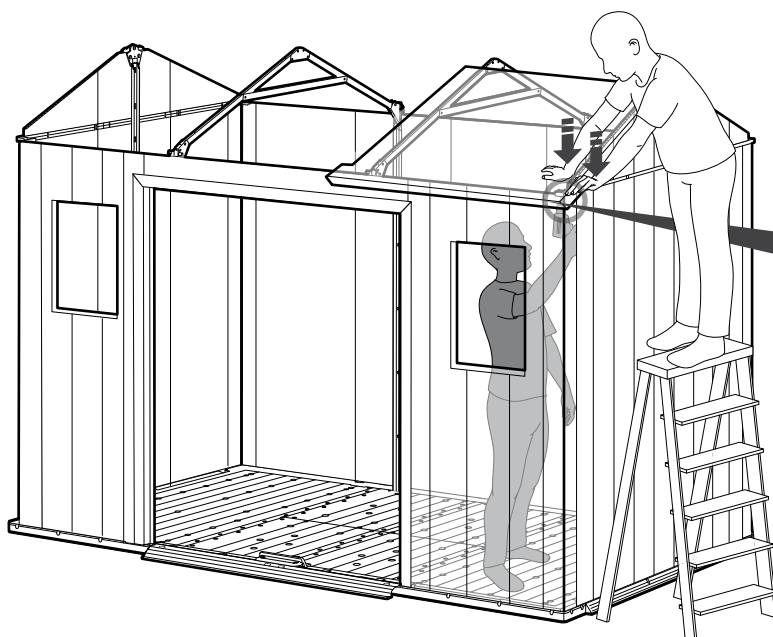
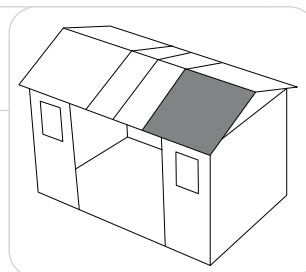

sc15 x 1

44

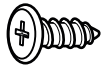

sc15 (x3)

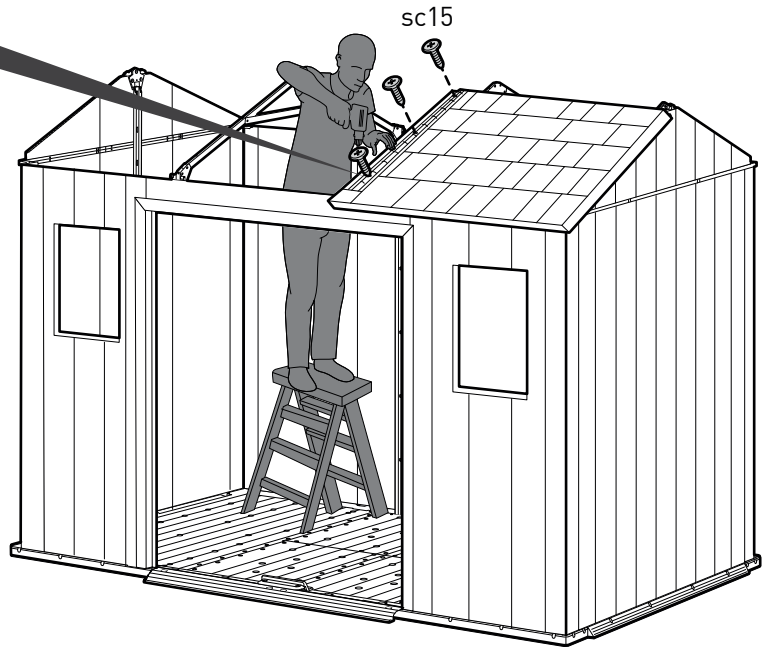
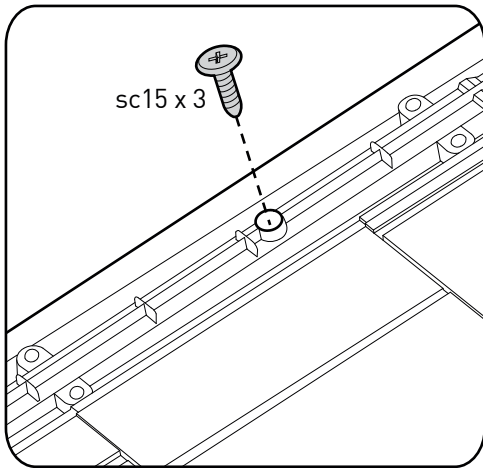
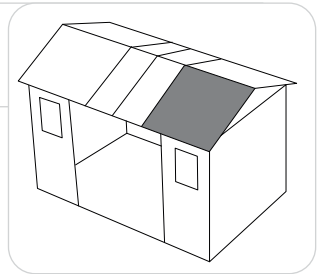

45



MOFT9+ MOFT9 (x1)

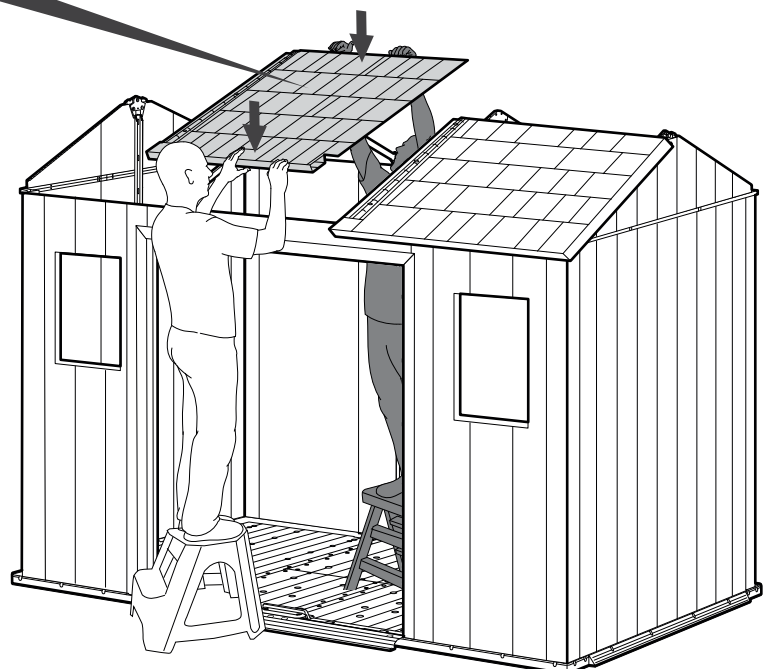
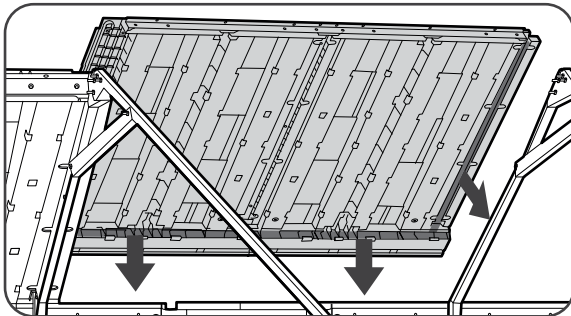
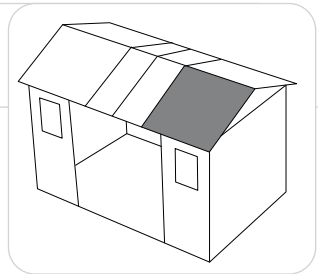

46



sc15 (x3)

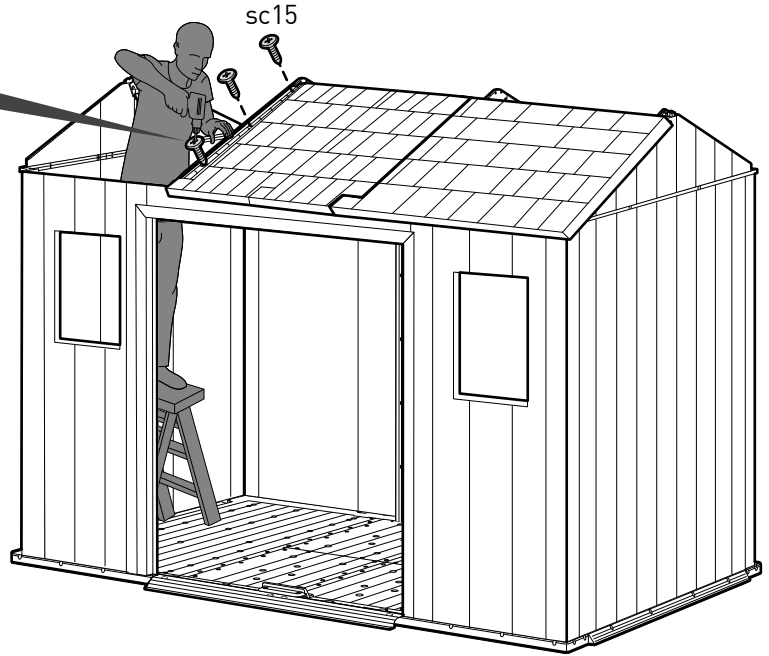
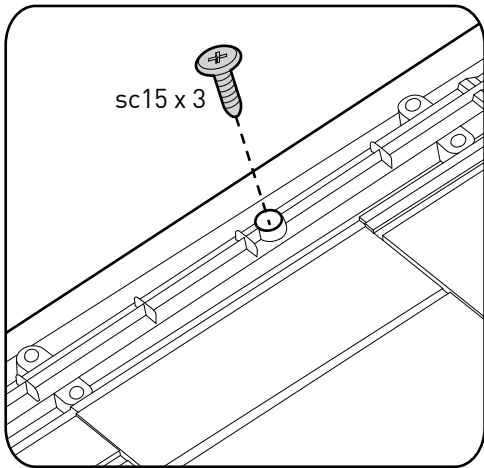
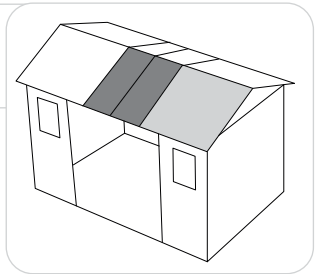

47

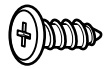

sc15 (x8)

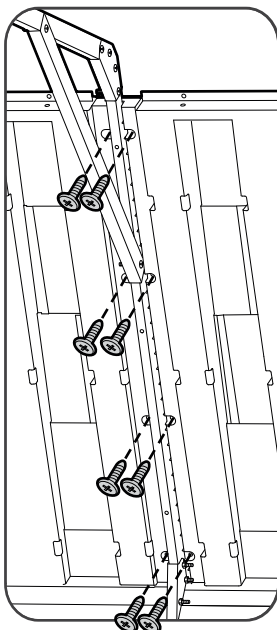
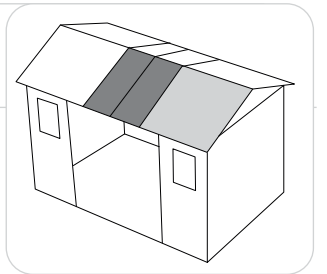



48

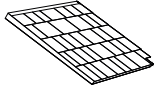

MOFTU (x1)

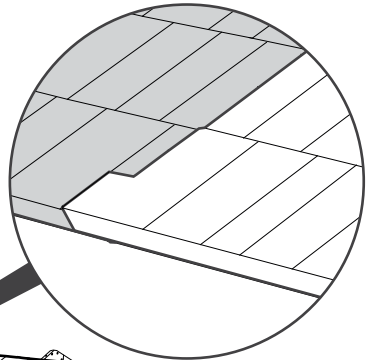
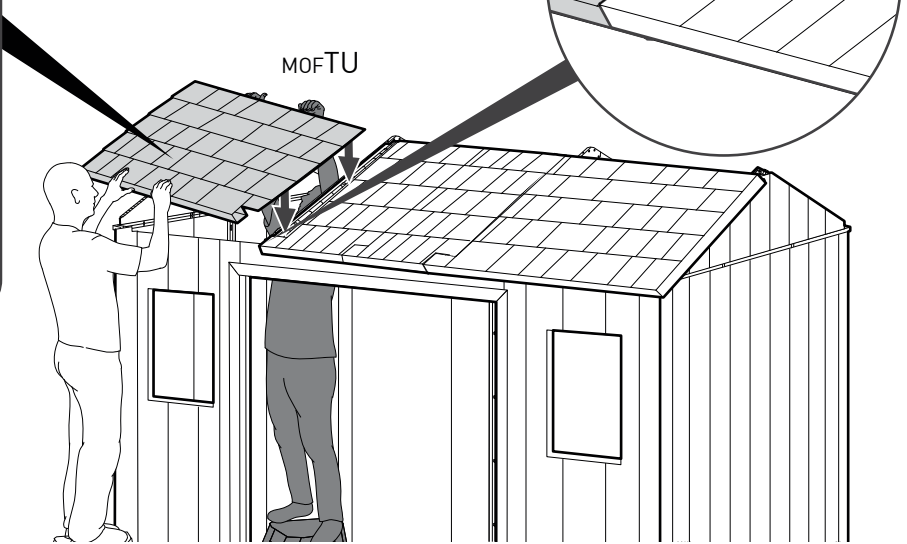
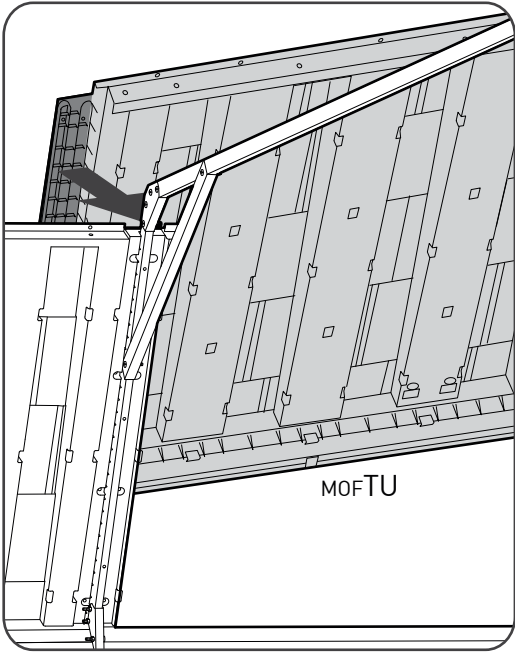
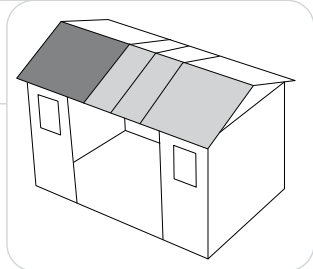

49

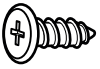

sc15 (x8)

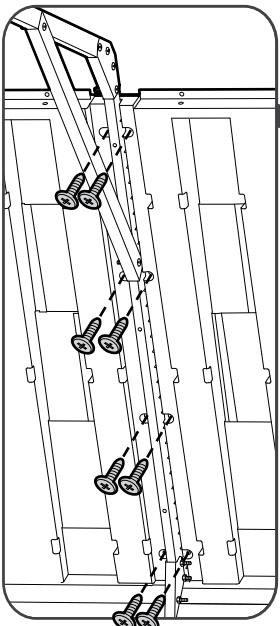
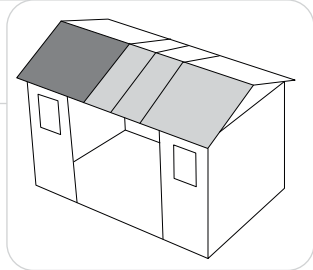

sc15 x 8

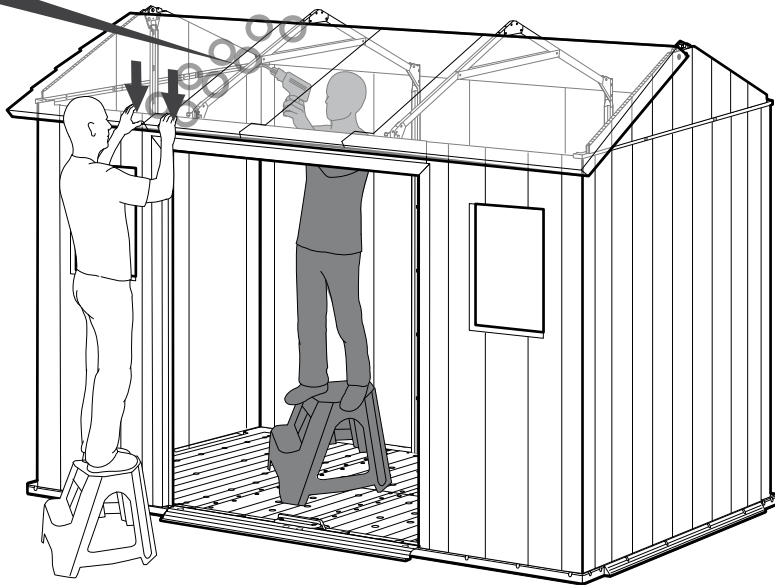

50

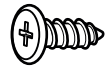

sc15 (x1)

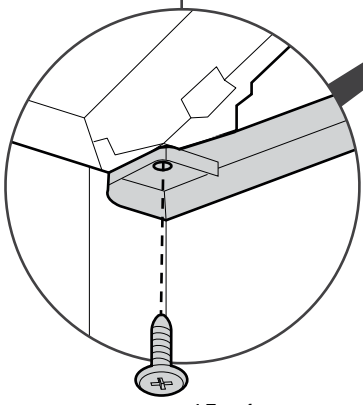
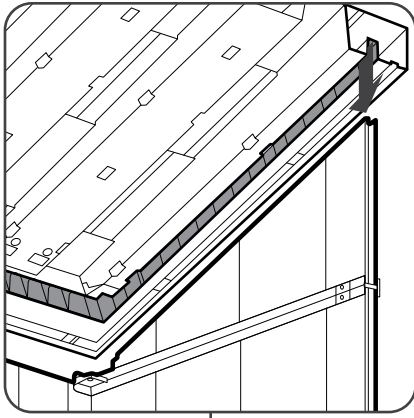
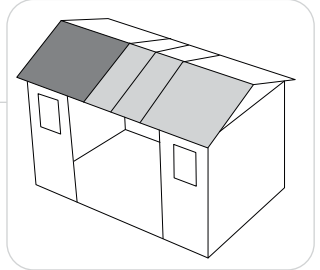

sc15 x 1

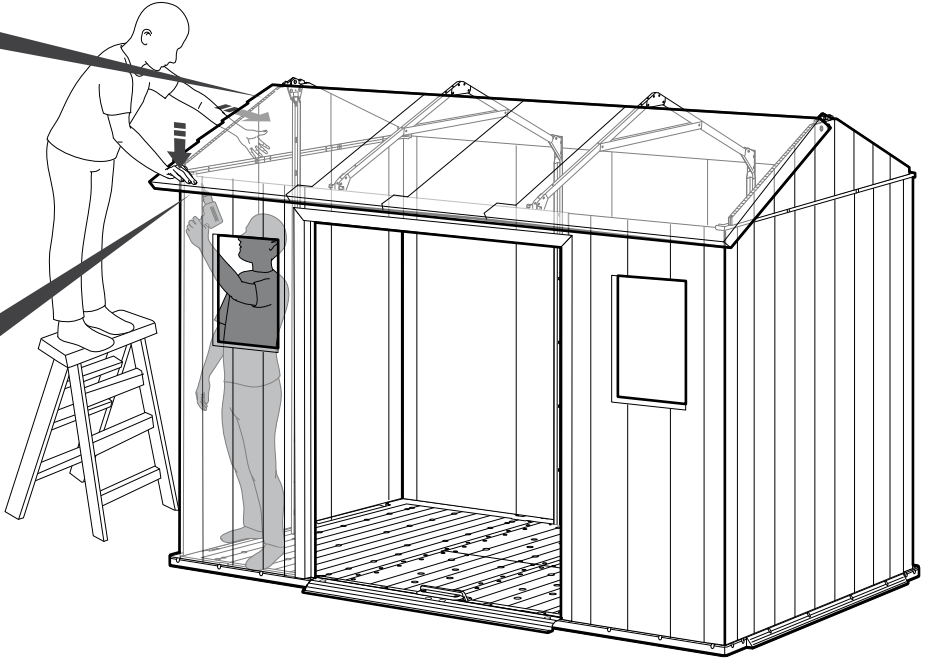

51



MoFTD (x1)

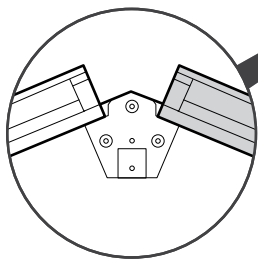
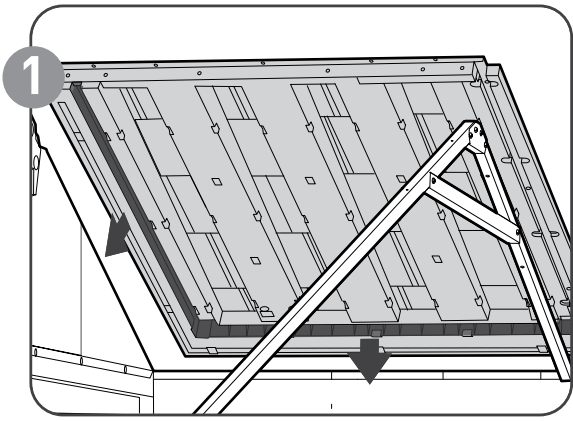
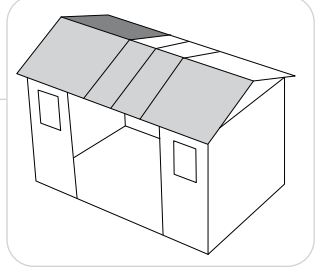

MoFTD

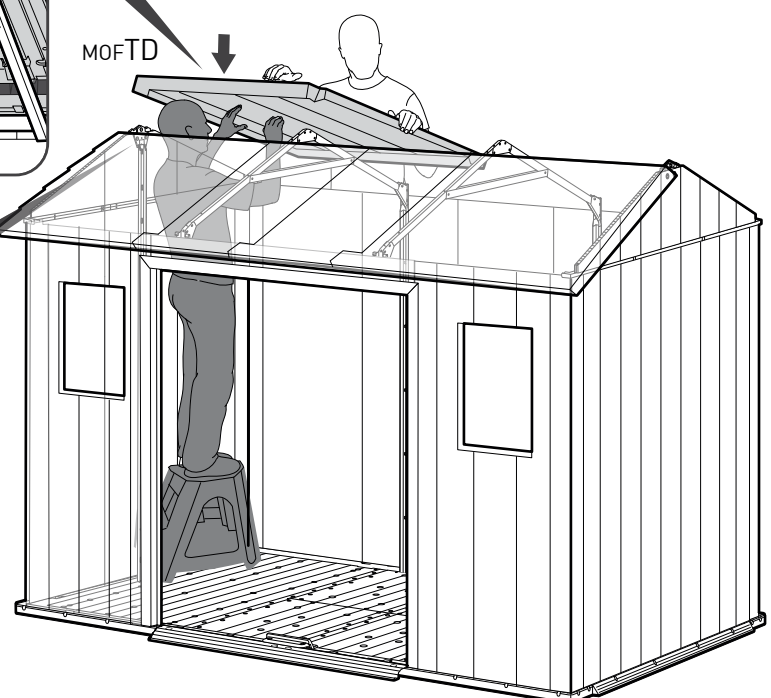

52

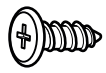

sc15 (x1)

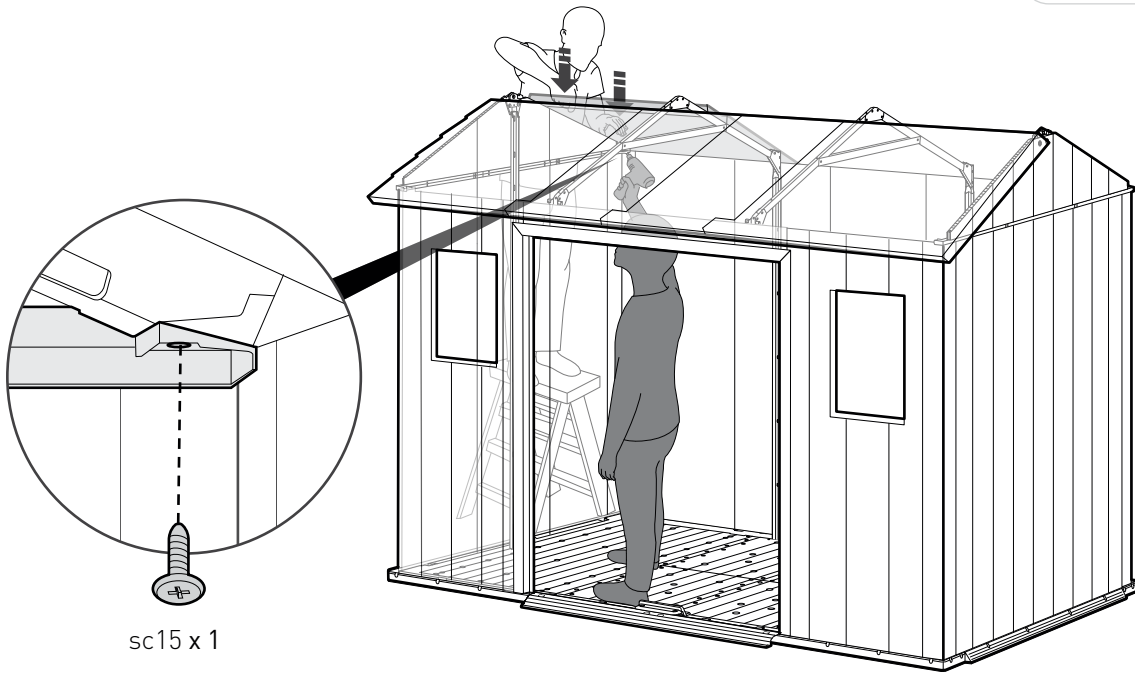
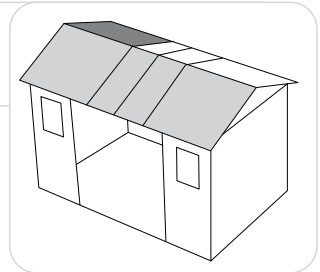

sc15 x 1

53

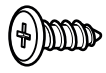

sc15 (x3)

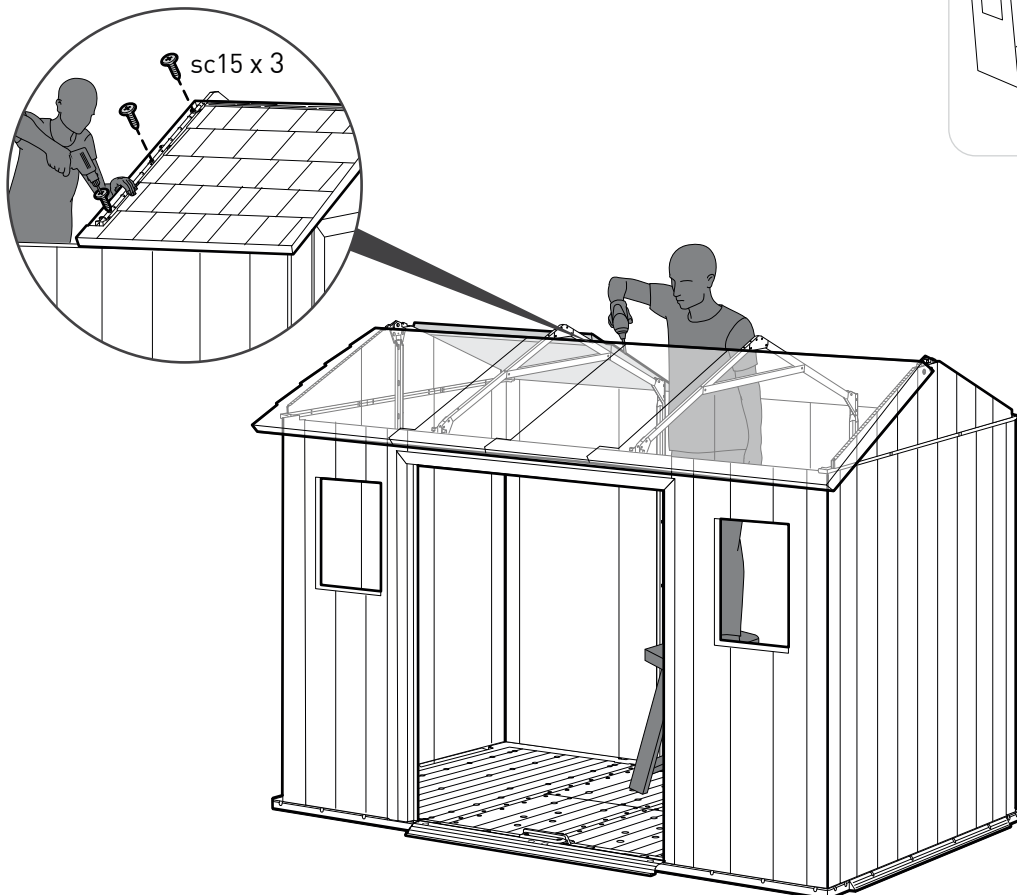
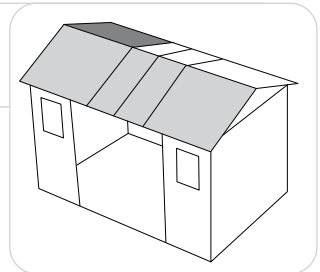

sc15 x 3

54



MOFT9 + MOFT9 (x1)



sc15 (x3)

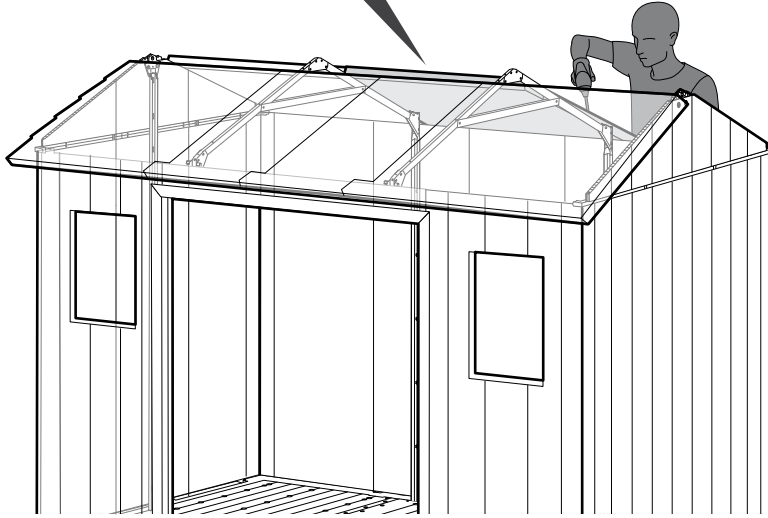
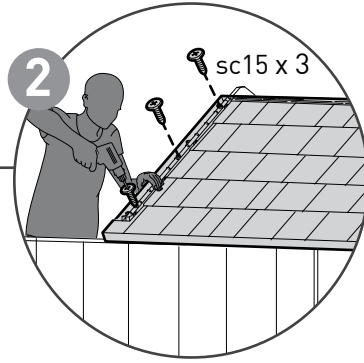
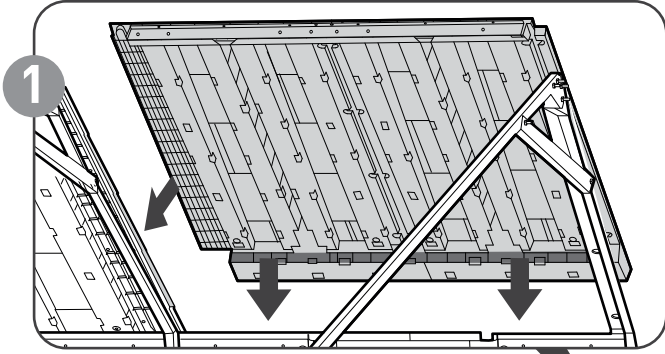
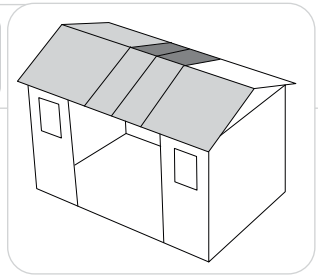

55

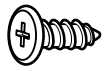

sc15 (x8)

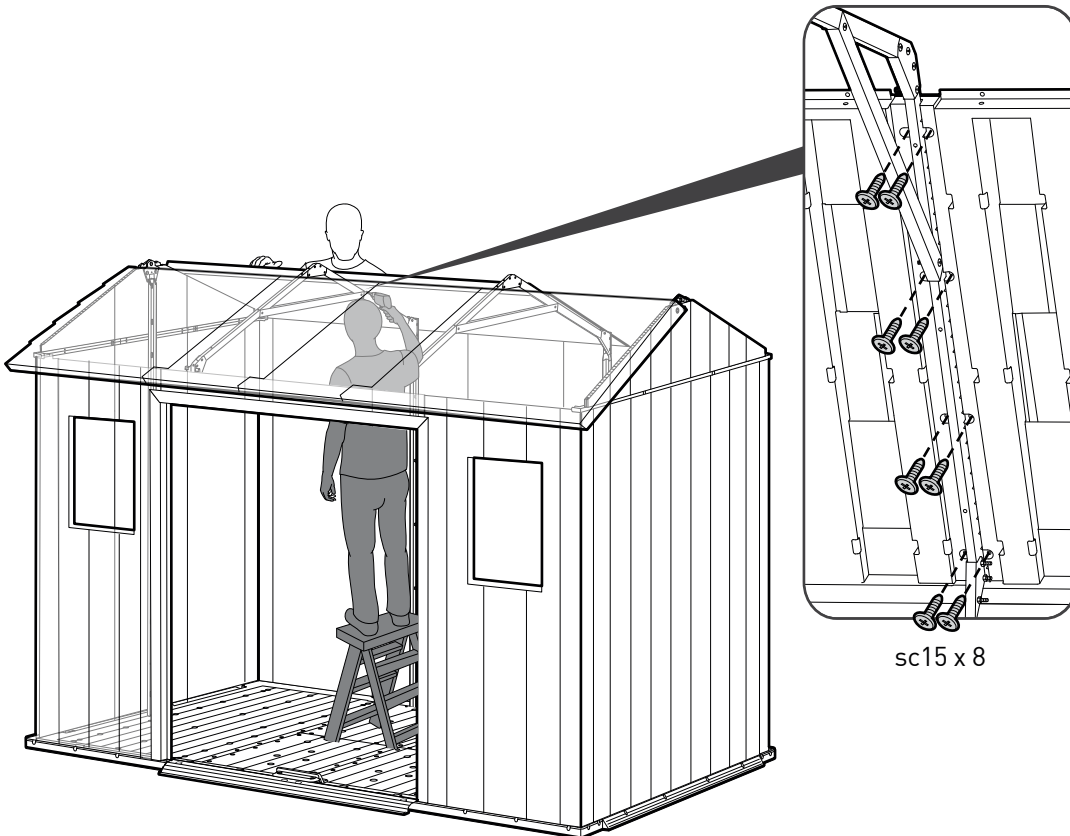
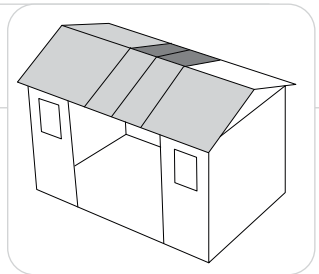

56

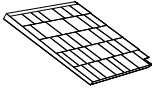

MOFTU (x1)

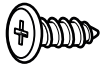

sc15 (x8)

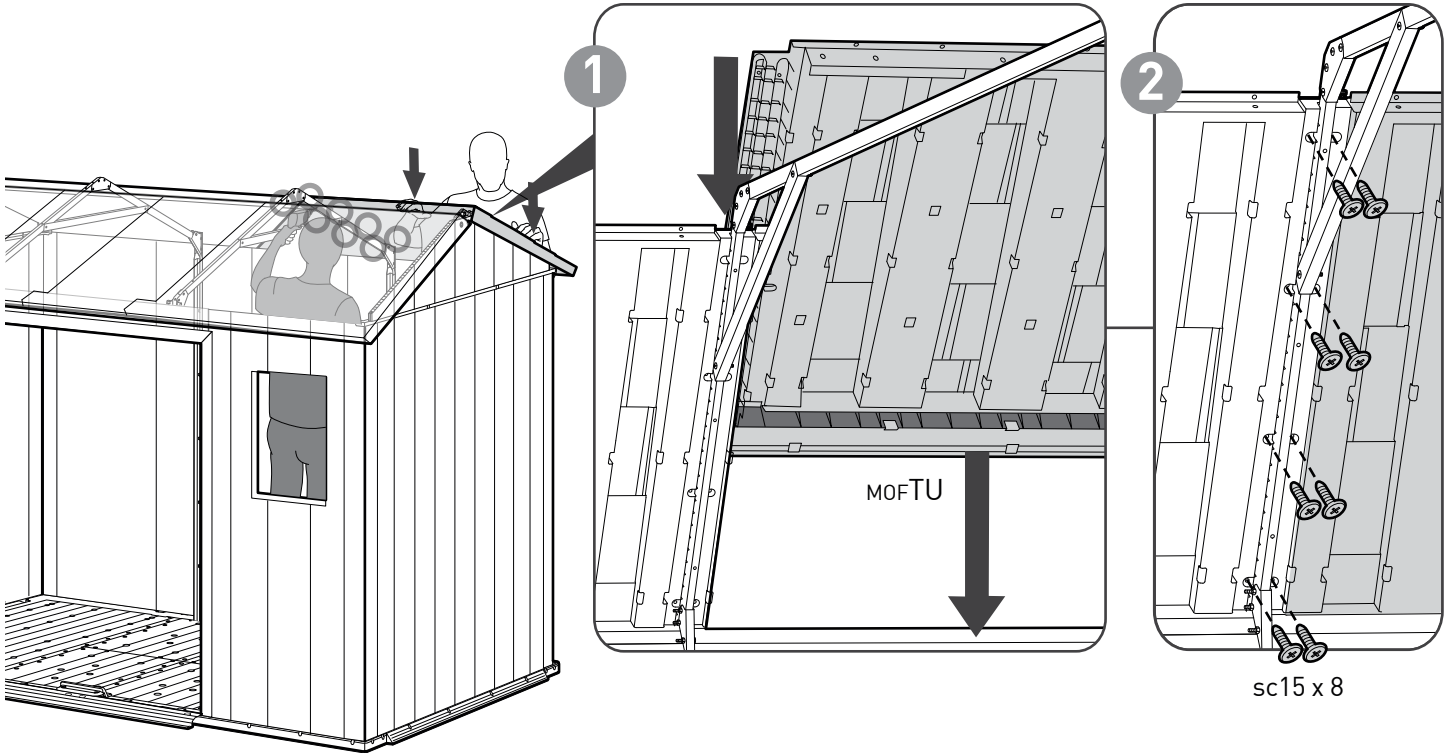
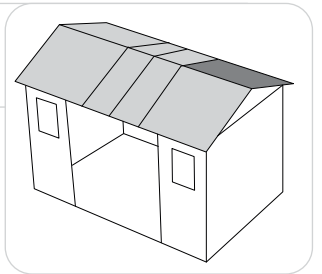

57

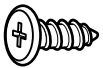

sc15 (x1)

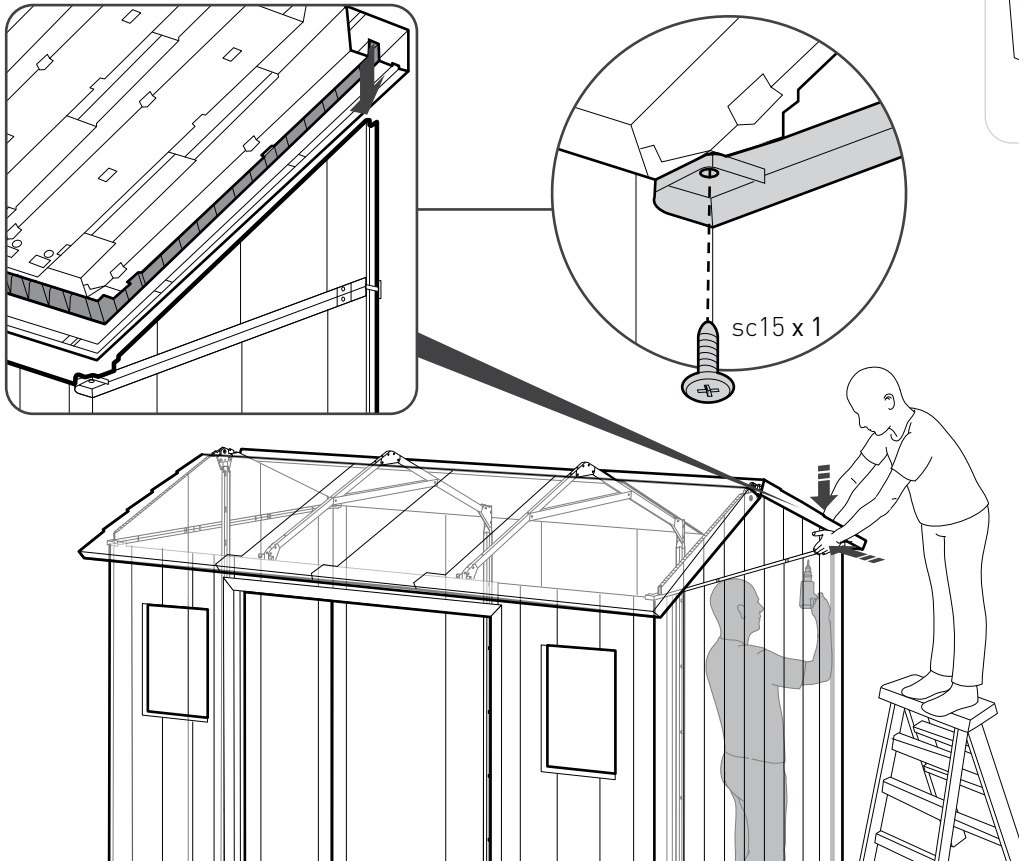
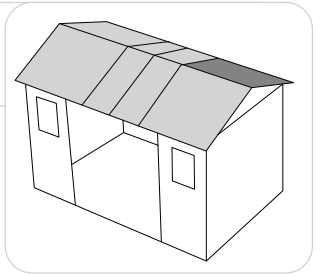

58

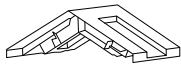

moBC9 (x1)



sc15 (x4)

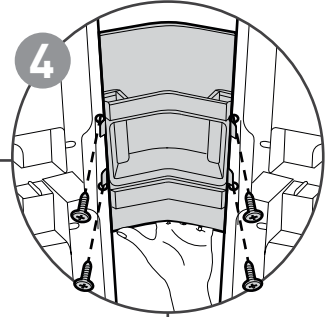
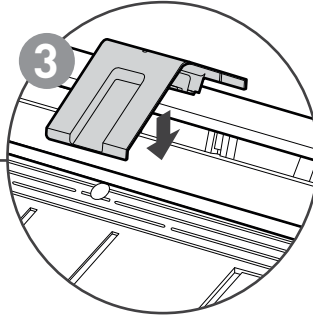
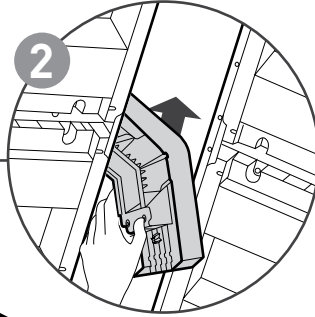
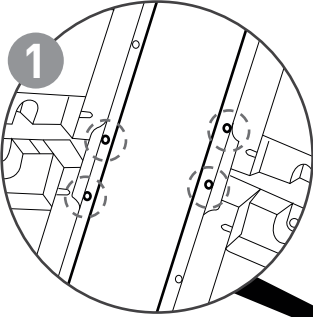
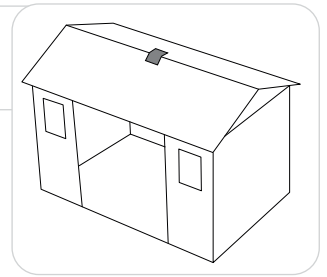

moBC9

sc15 x 4

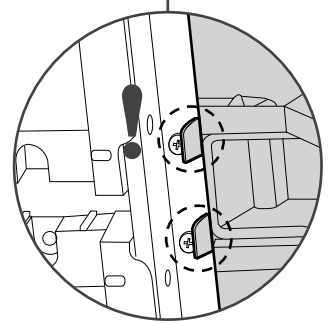
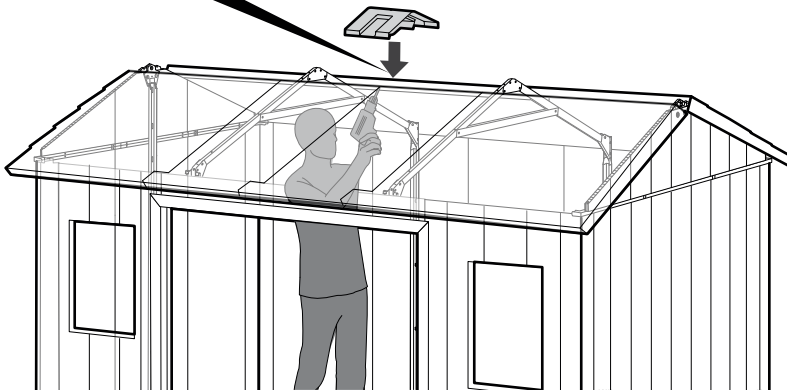

59

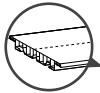

moB11(x2)



moPLS (x2)

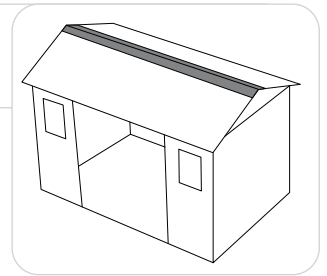

x2

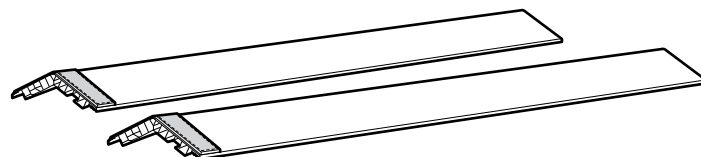
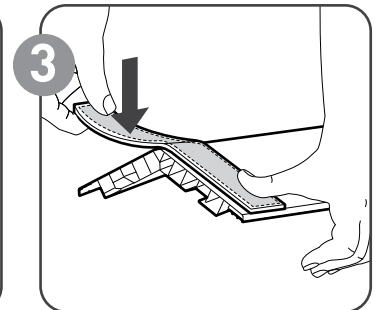
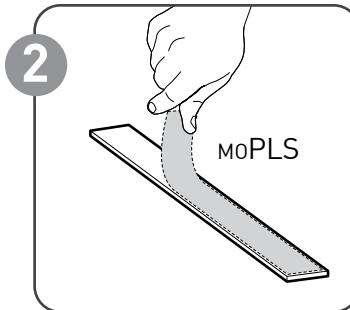
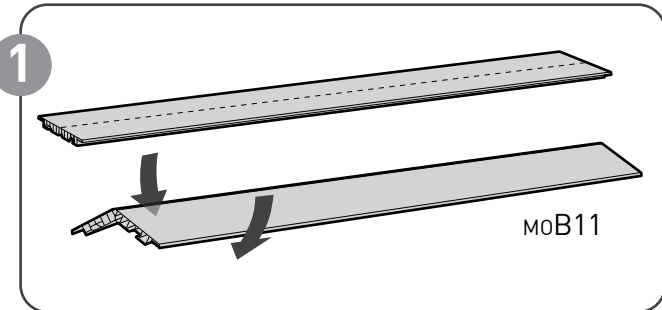

60

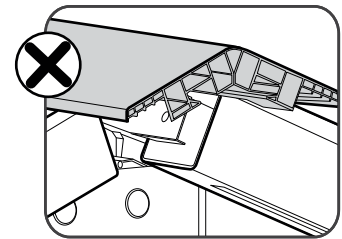
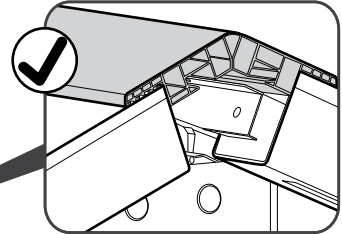
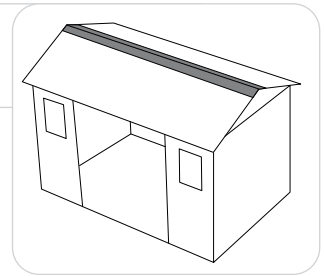
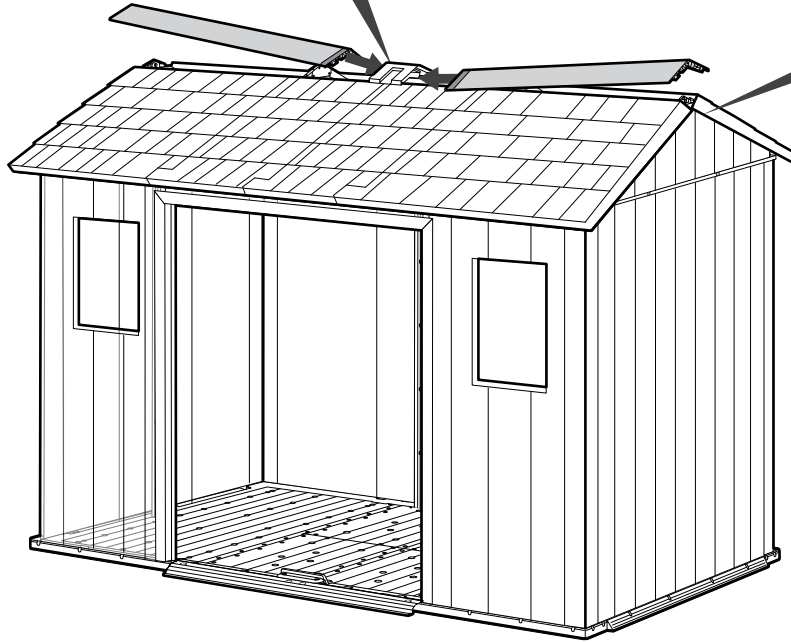
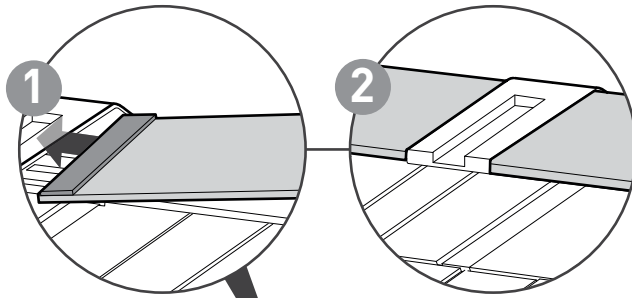

61

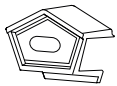

MoAC (x1)

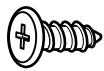

sc15 (x3)

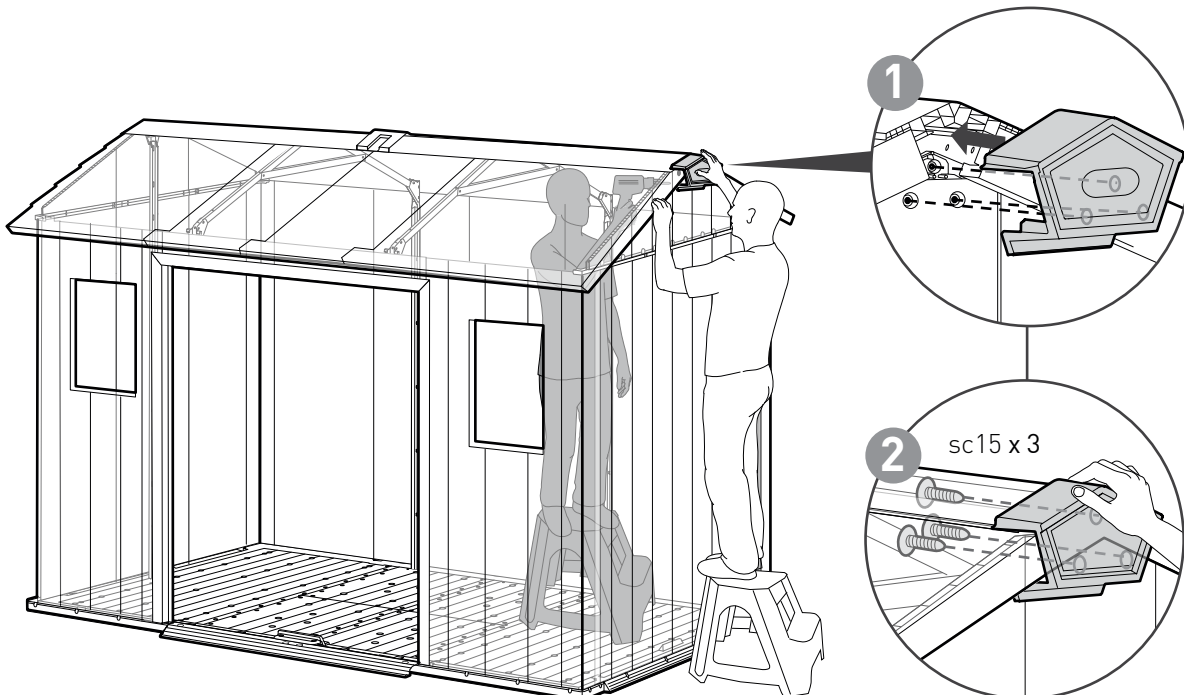
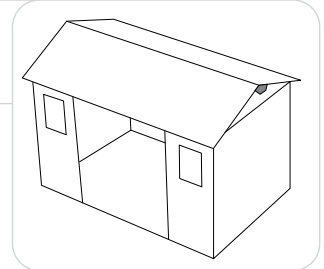

62

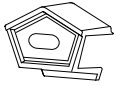

MOAC (x1)

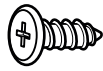

sc15 (x3)

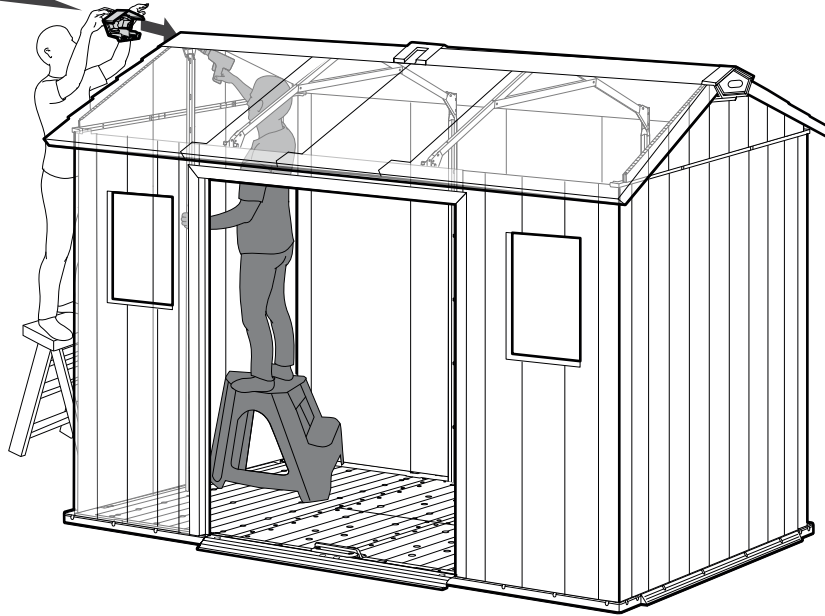
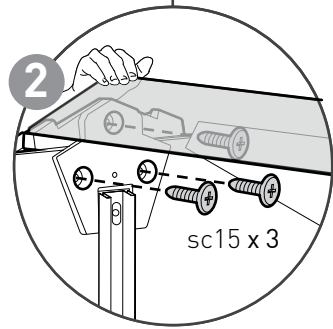
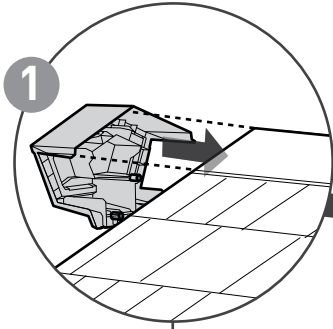
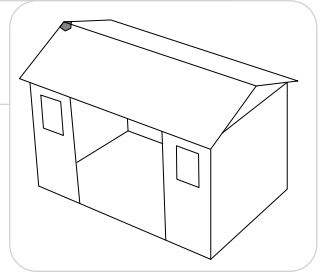

63

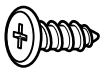

sc15 (x32)

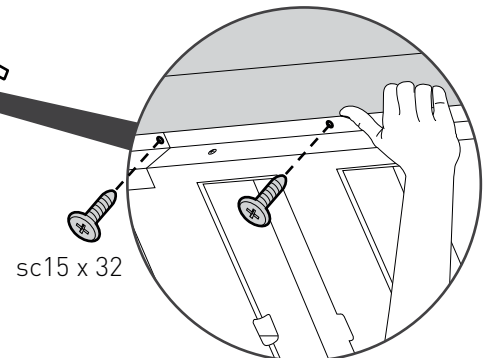
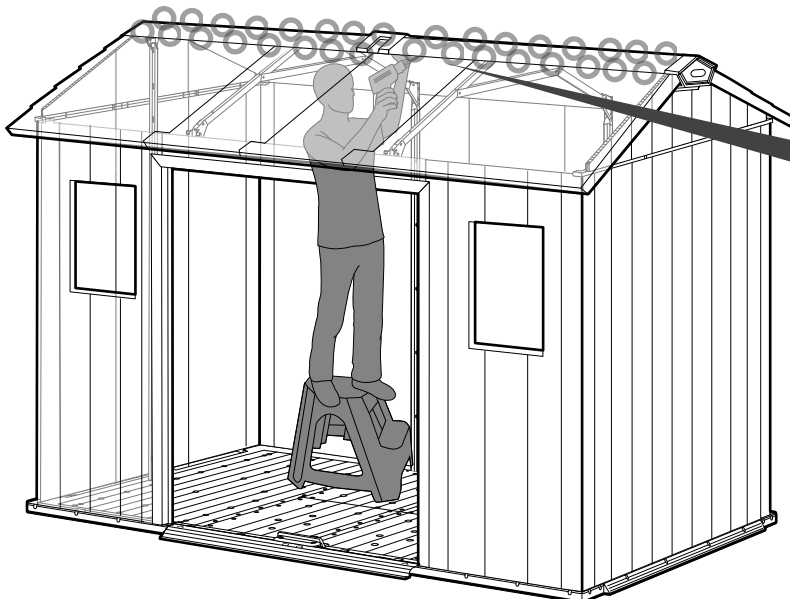
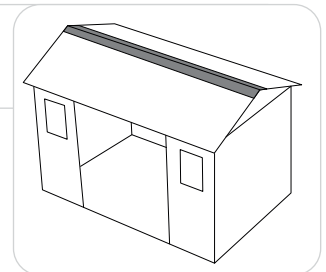



64

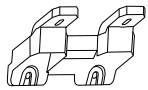

MoFTC (x4)

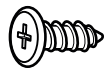

sc15 (x8)



s45b (x8)

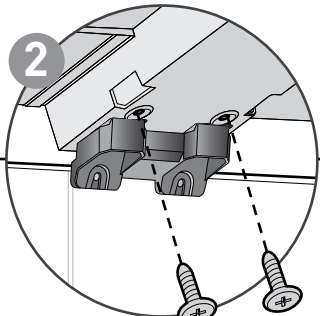
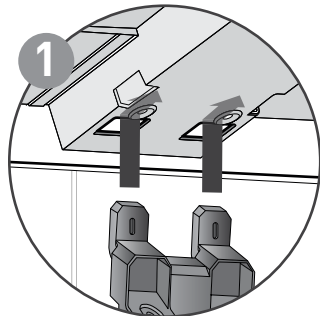
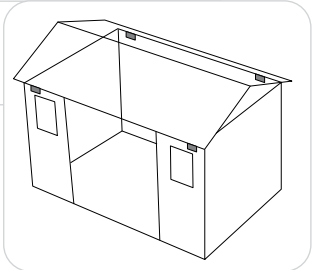

sc15 x 2

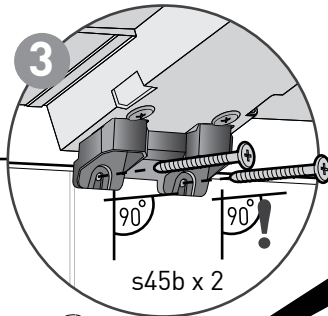

s45b x 2

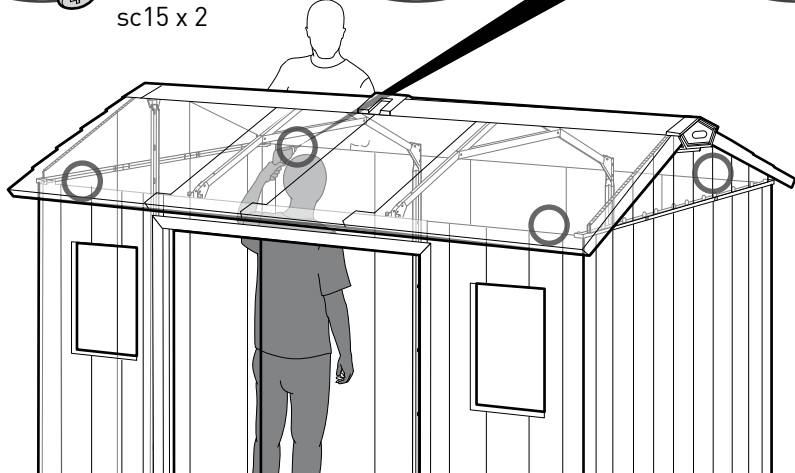
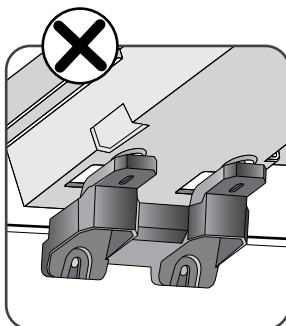
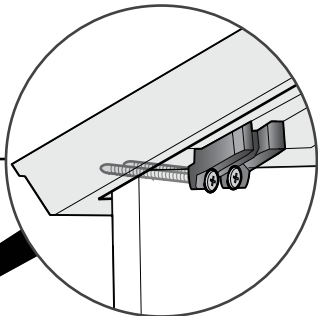

65



FNTM (x8)

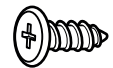

sc15 (x8)

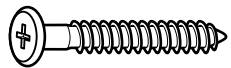

s45b (x8)

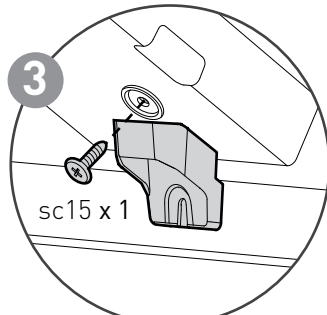
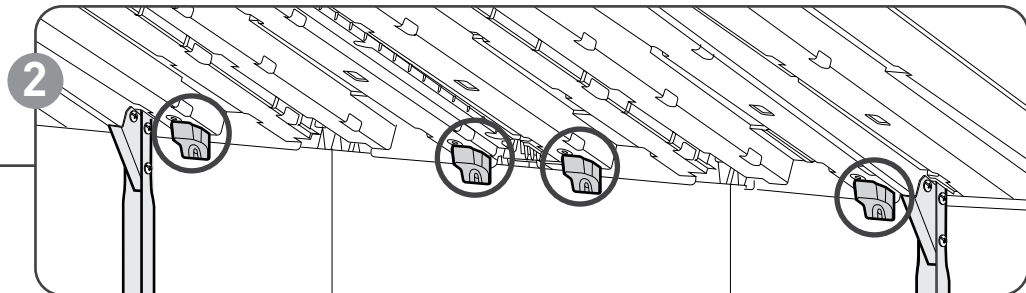
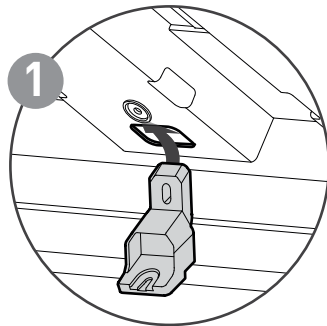
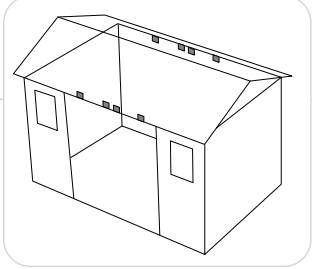

sc15 x 1

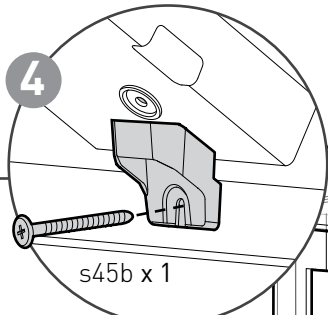

s45b x 1

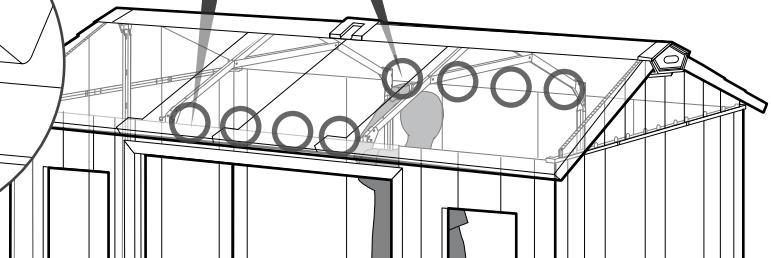

66



sc15 (x10)

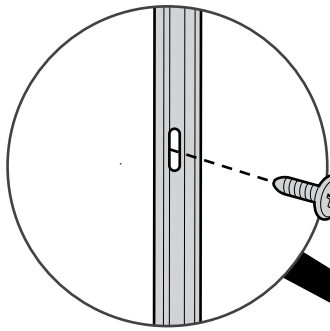
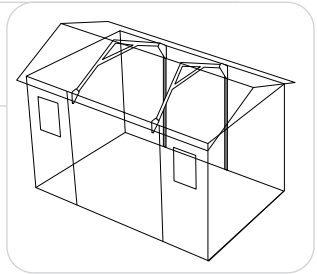

sc15

WSTĘPNIE NAWIERĆ OTWORY

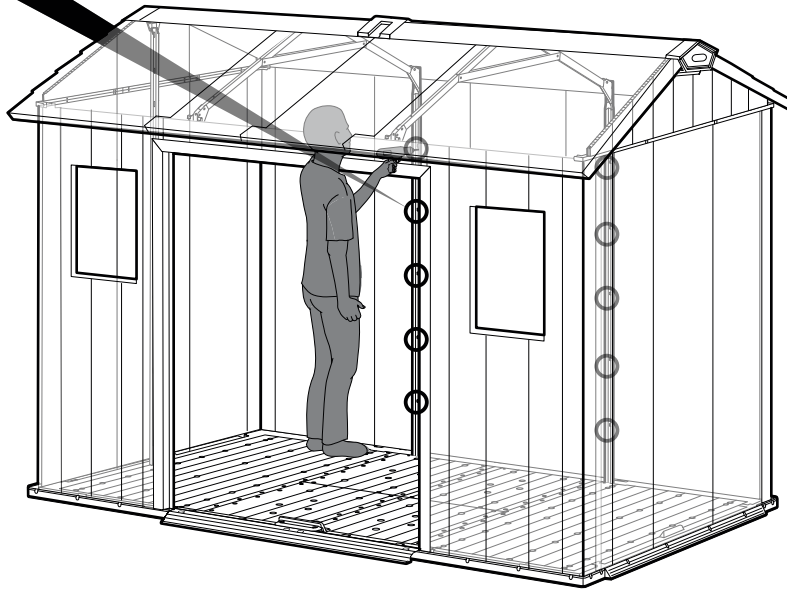

67

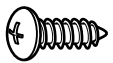

s13b (x36)

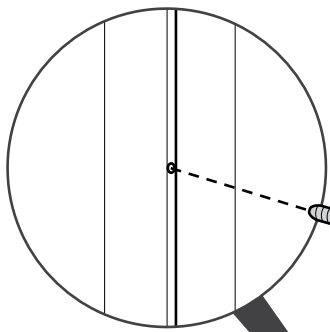
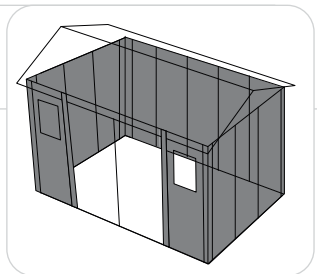

s13b

s13b x 2

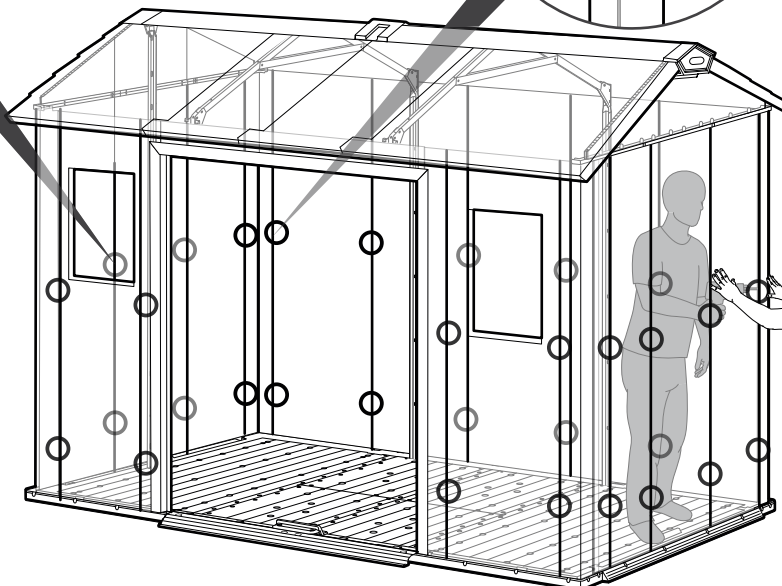
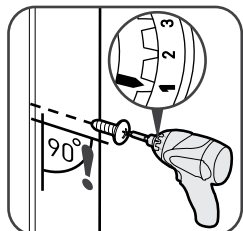
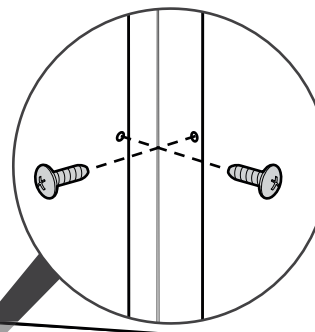

68



sc15 (x12)

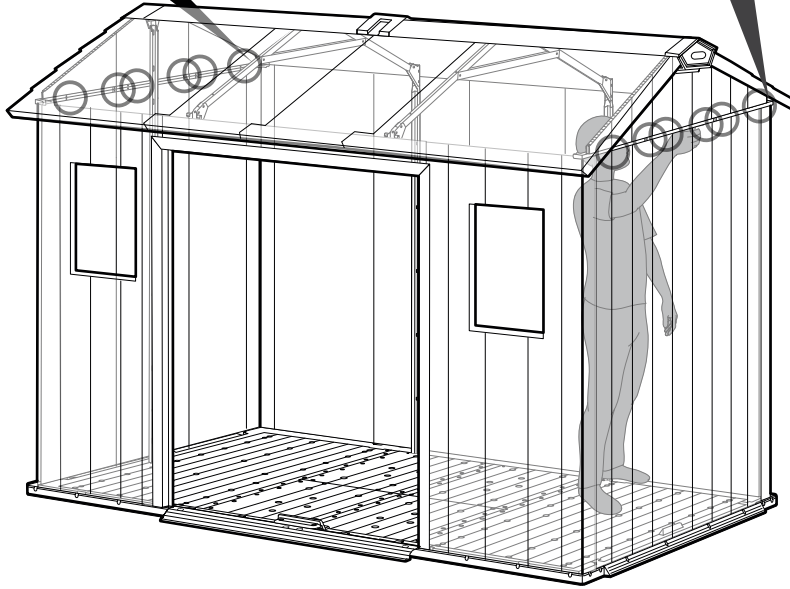
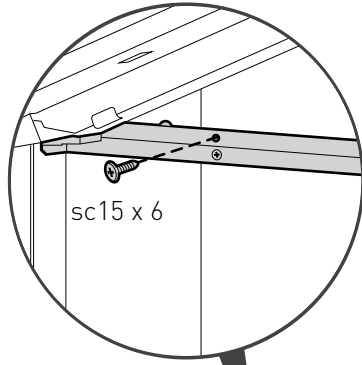
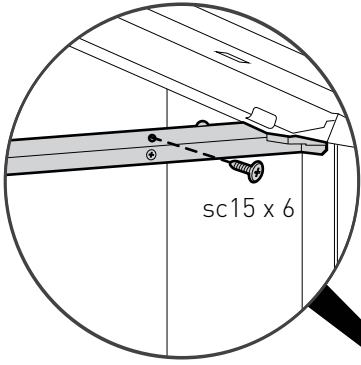
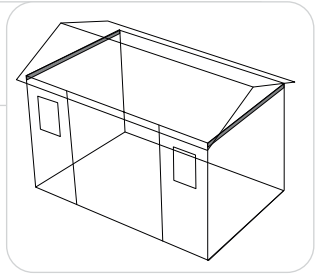

69



sc12 (x34)

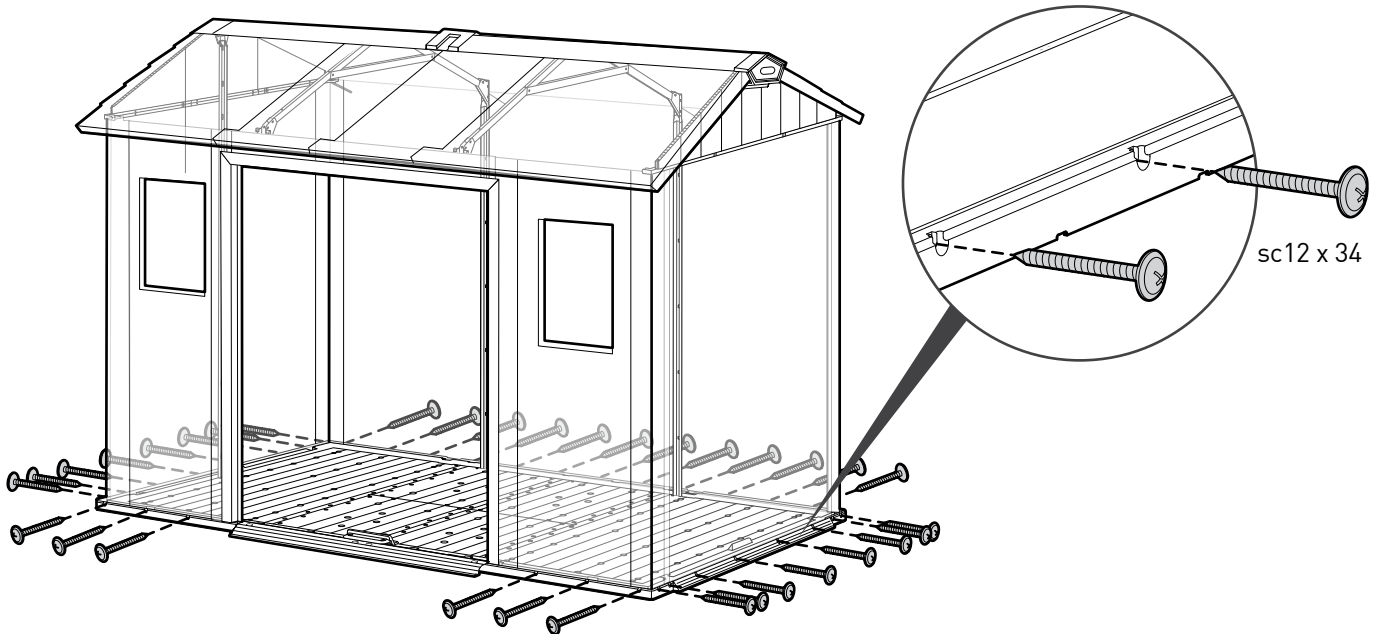
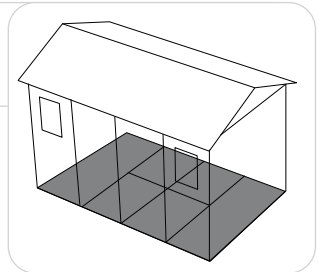

70

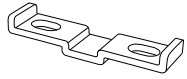

moRC (x6)



sc15 (x12)

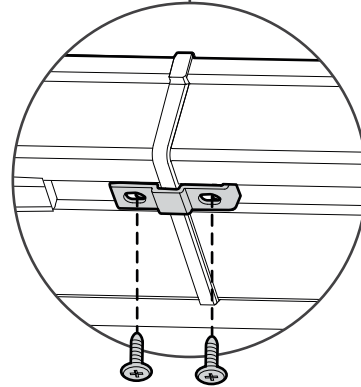
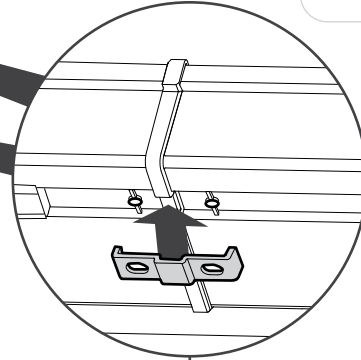
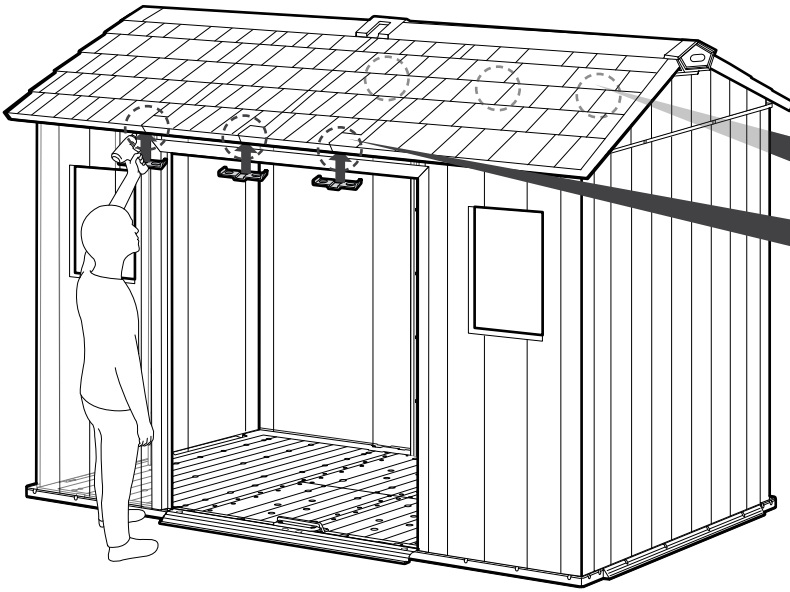
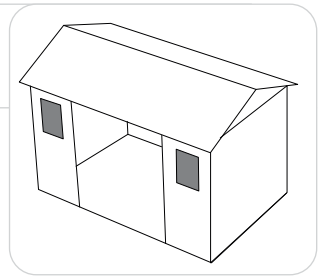

## MONTAŻ DRZWI

71

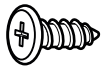

sc15 (x12)

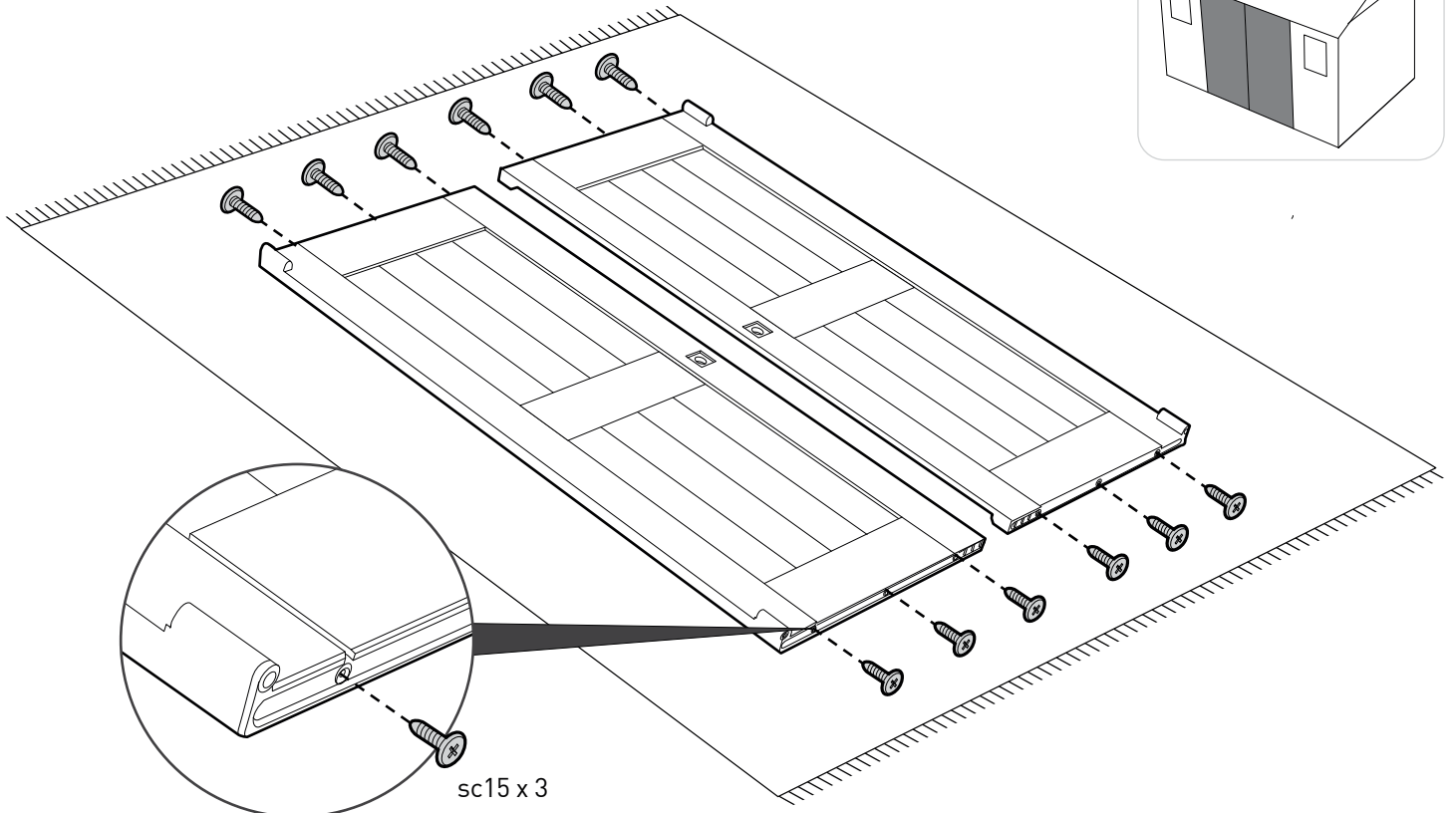
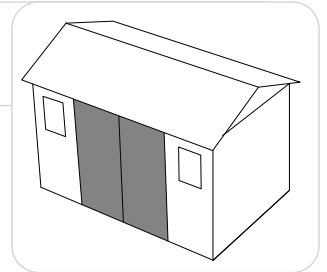

sc15 x 3

72

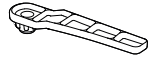

FNHL (x1)

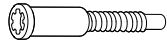

FNHD (x2)

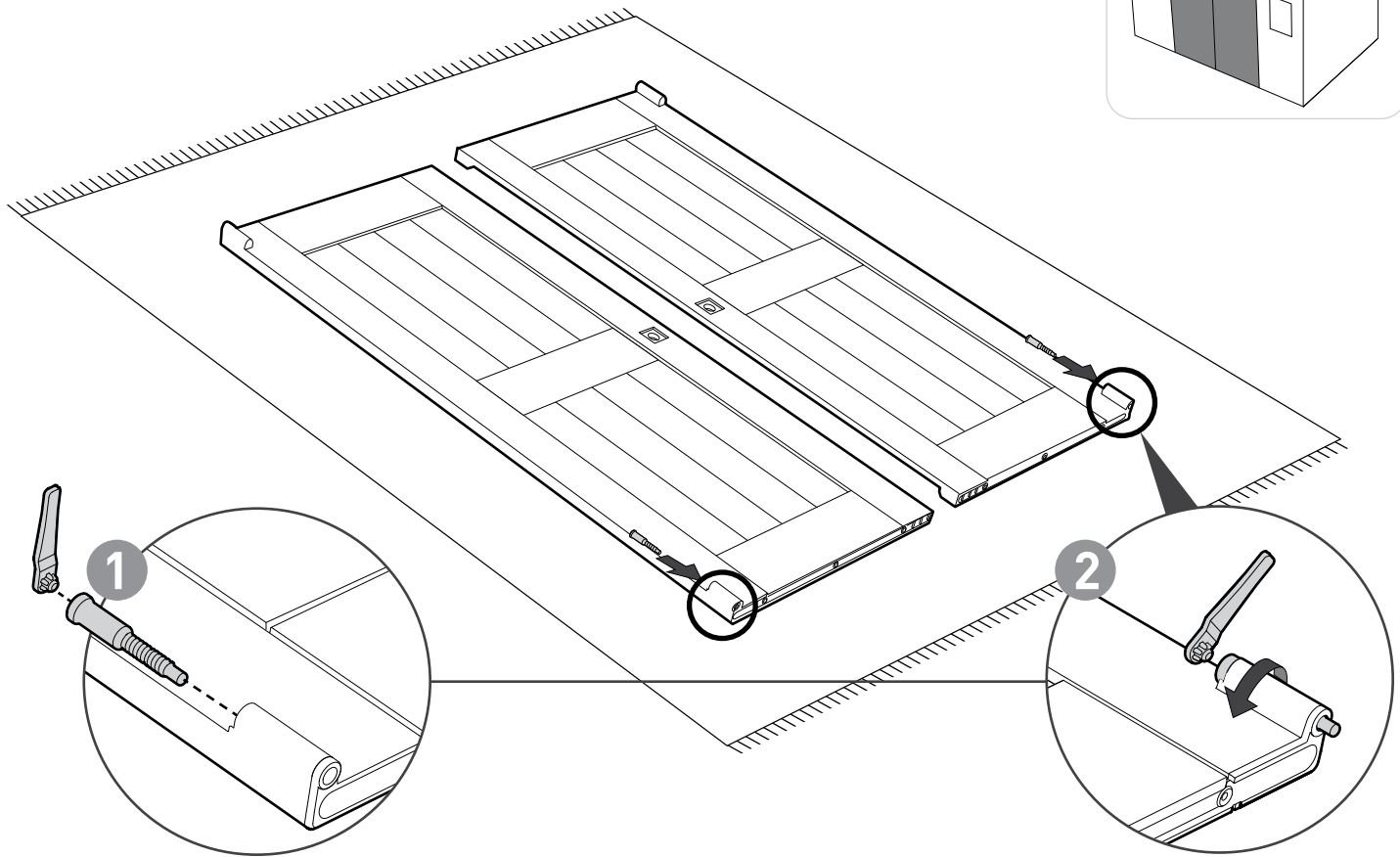
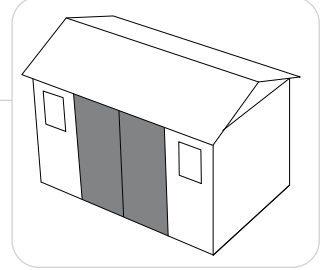

73



MoNW (x2)

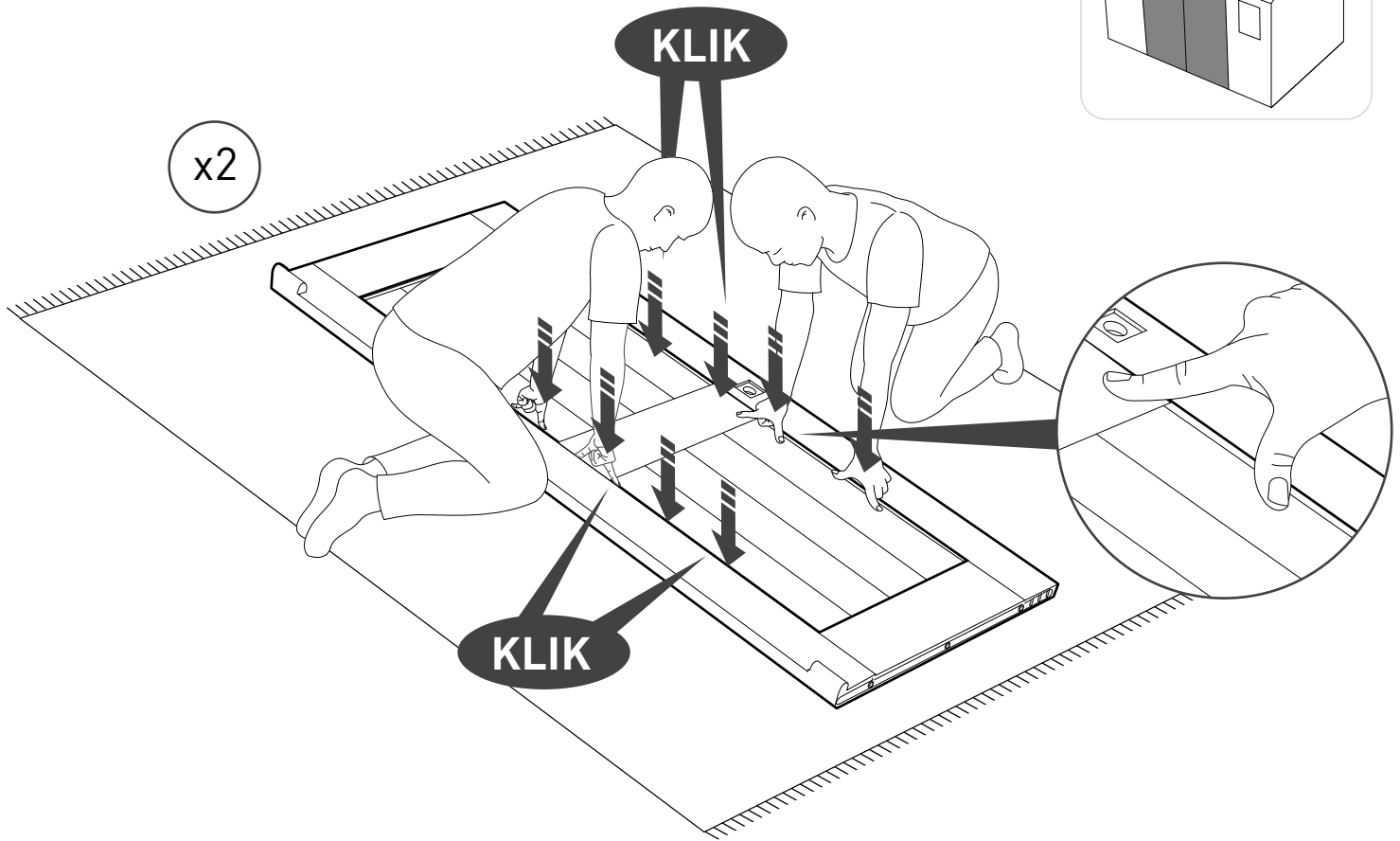
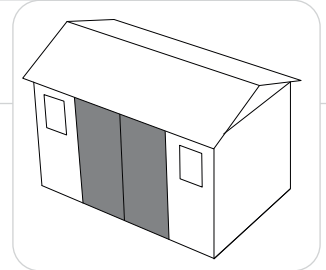



76

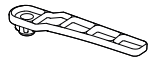

FNHL (x1)

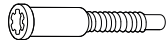

FNHD (x2)

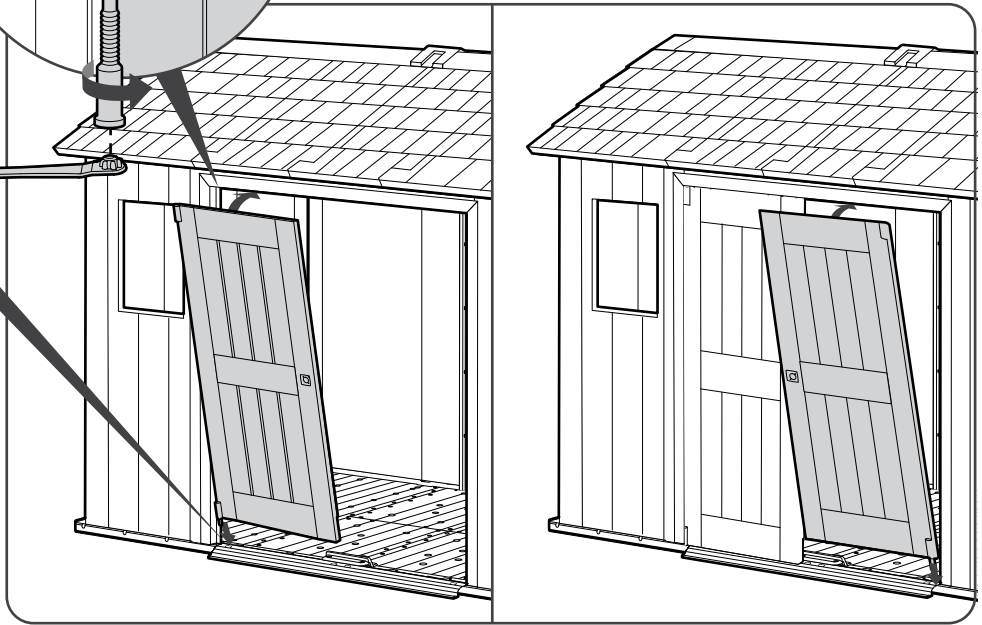
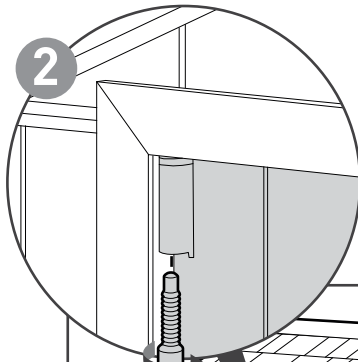
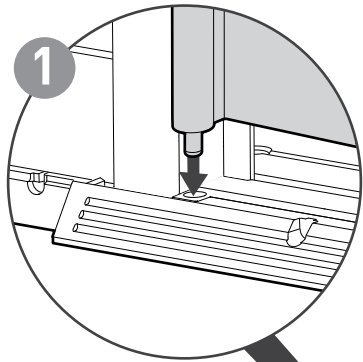
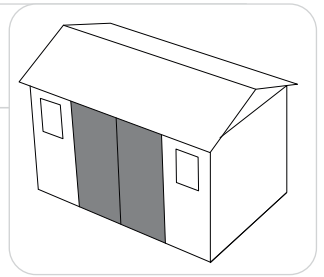

77

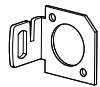

FNH6 (x1)

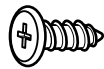

sc15 (x2)

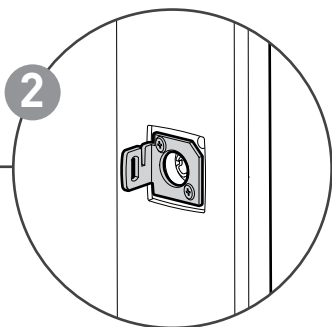
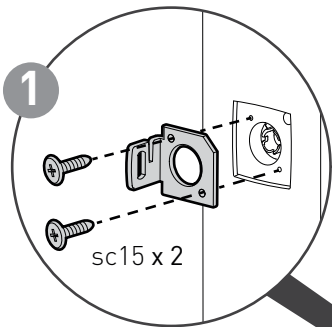
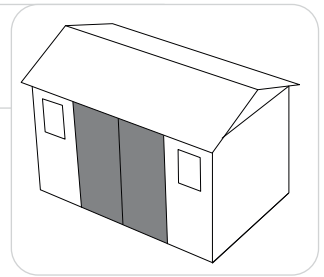

Lewe

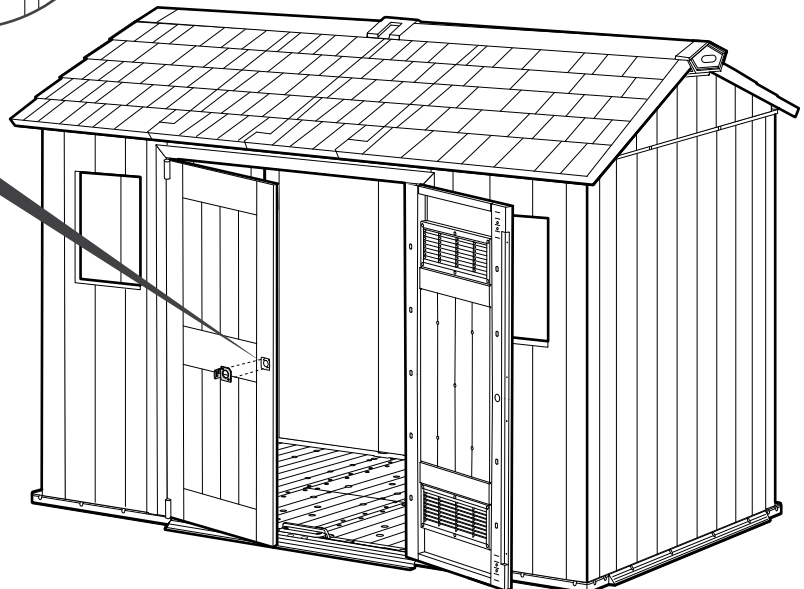

78



FNH5 (x1)



FNH4 (x1)



sc15 (x1)

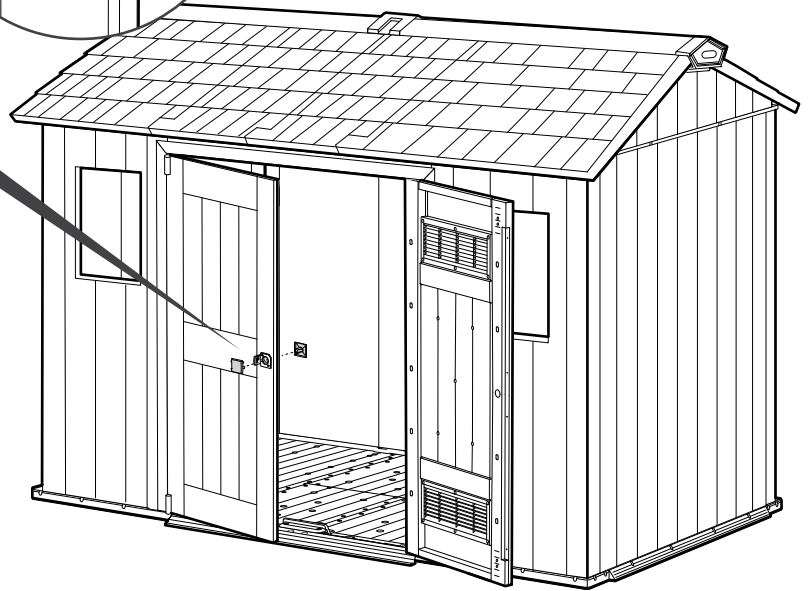
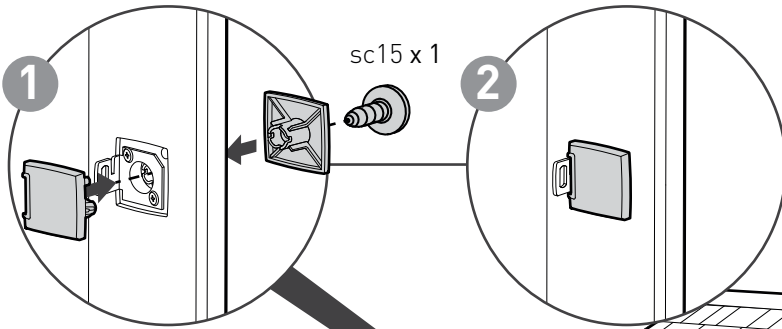
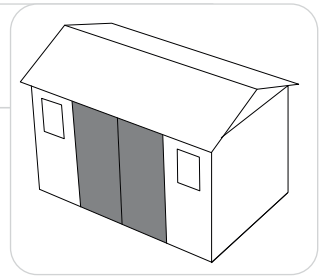

79

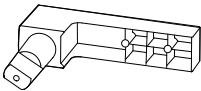

FNH1 (x1)

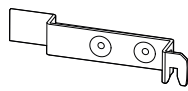

FNH7 (x1)



sc15 (x2)

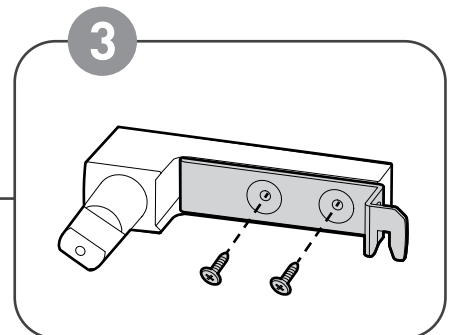
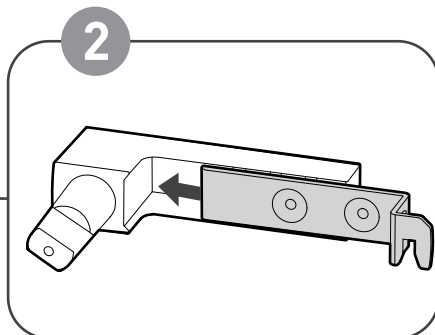
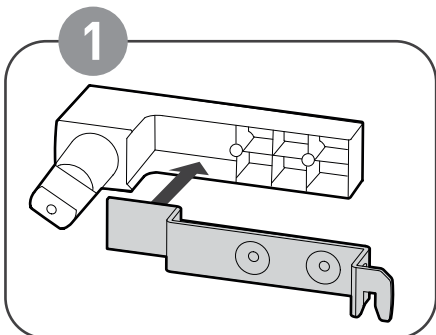
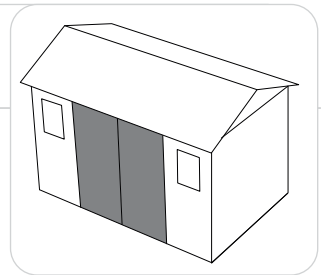

sc15 x 2



80

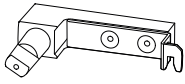

FNH2 (x1)



FNH3 (x1)



sc15 (x3)

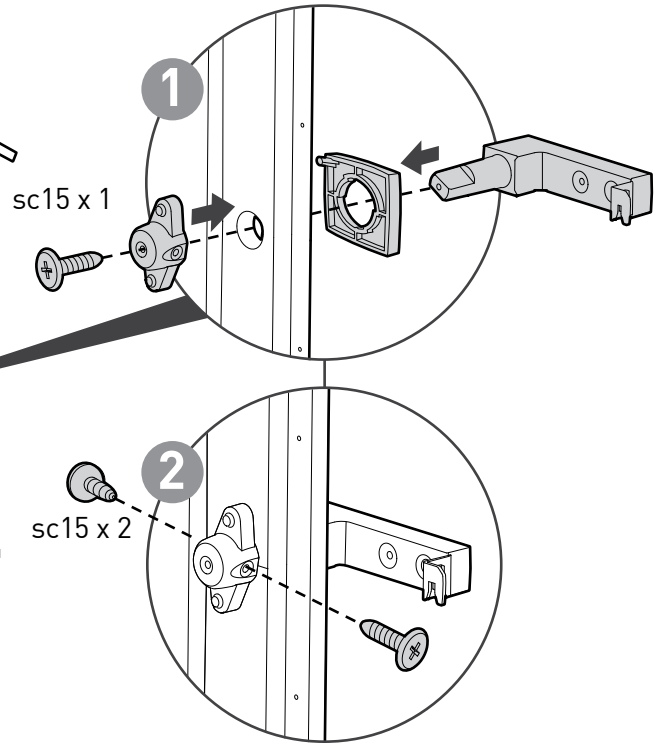
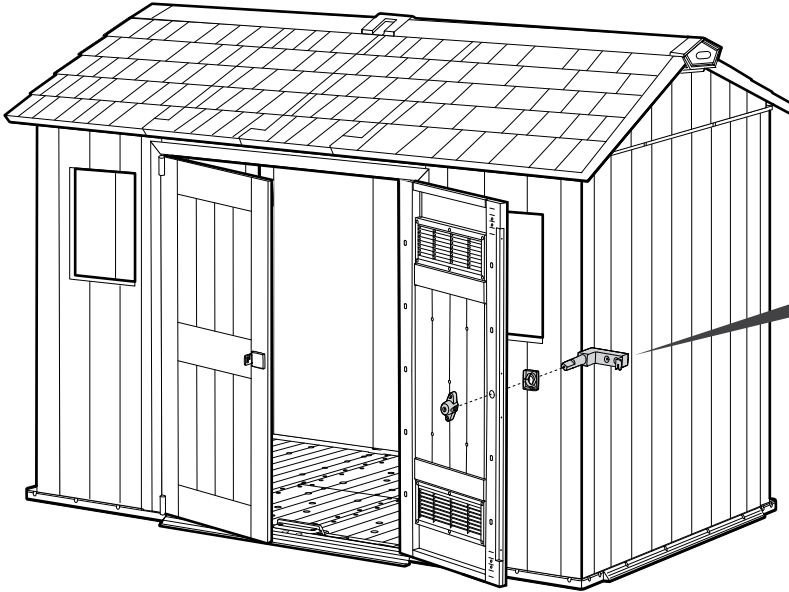
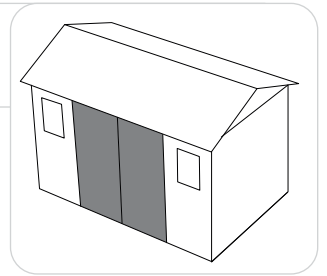

81



FNH8 (x2)



FNH9 (x2)



FNHA (x2)

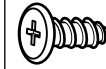

sc15 (x6)

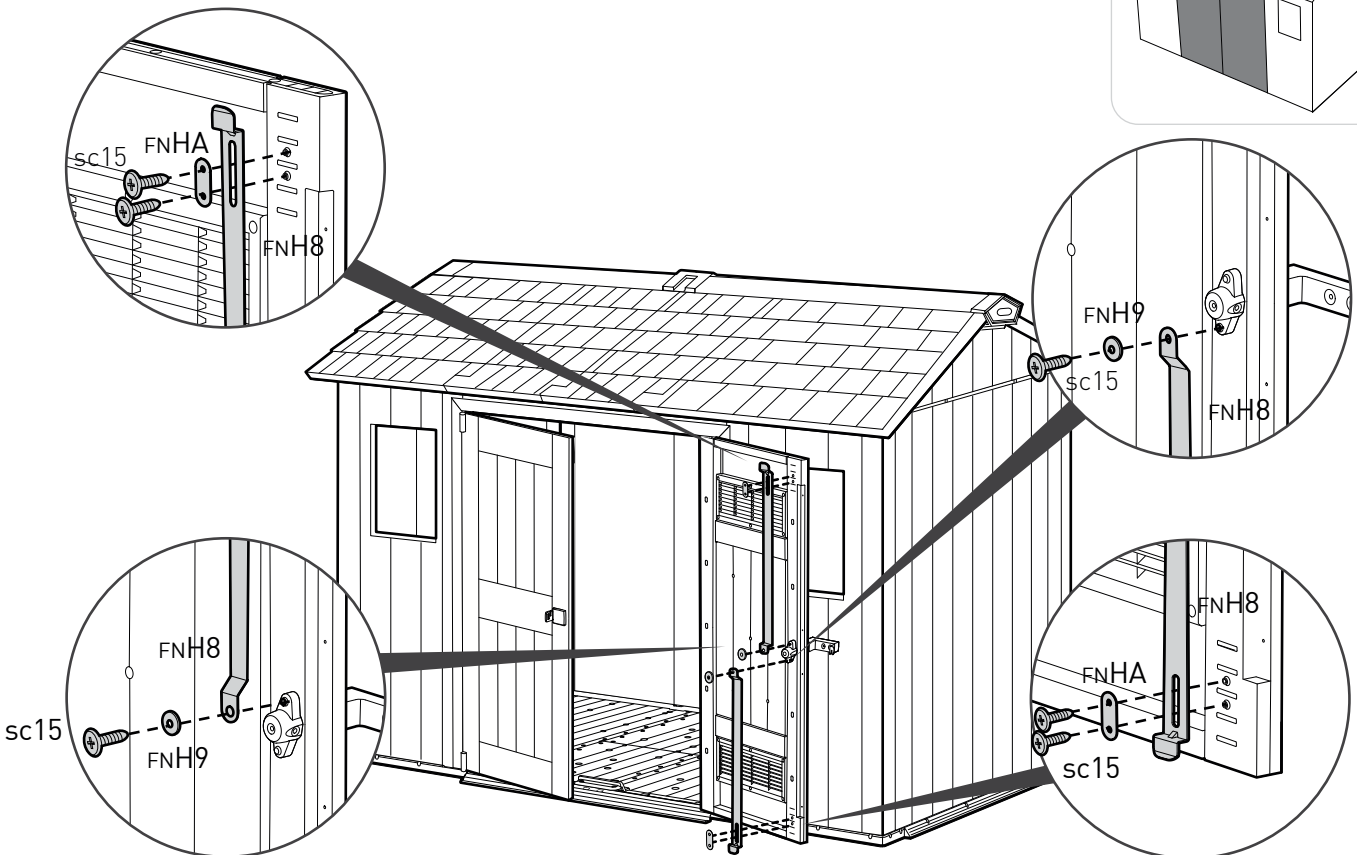
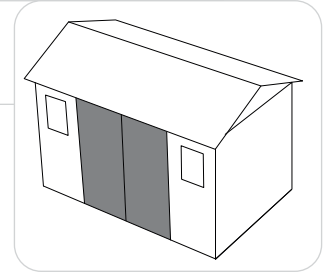

82

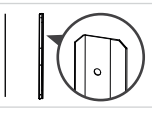

MOFMS (x1)

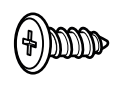

sc15 (x8)

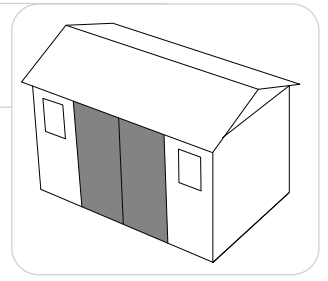

Lewe

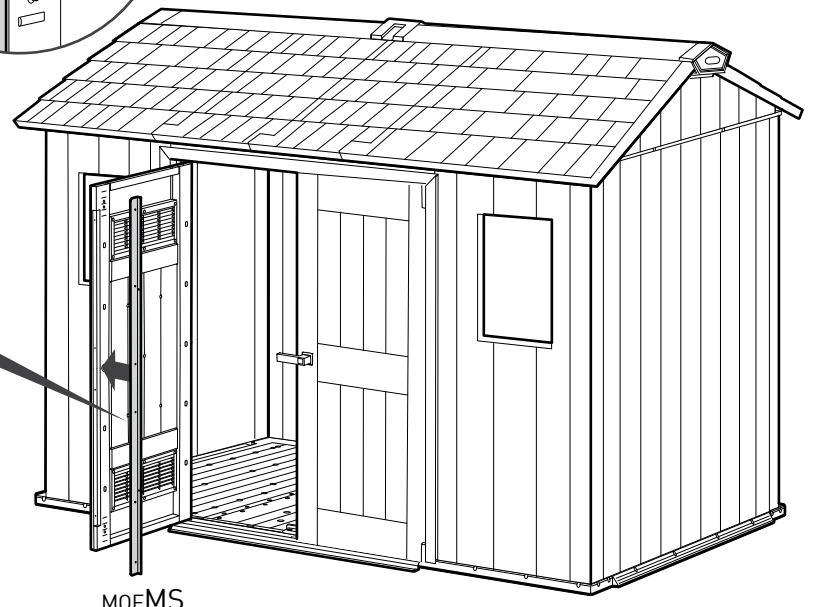
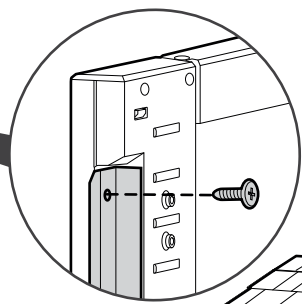
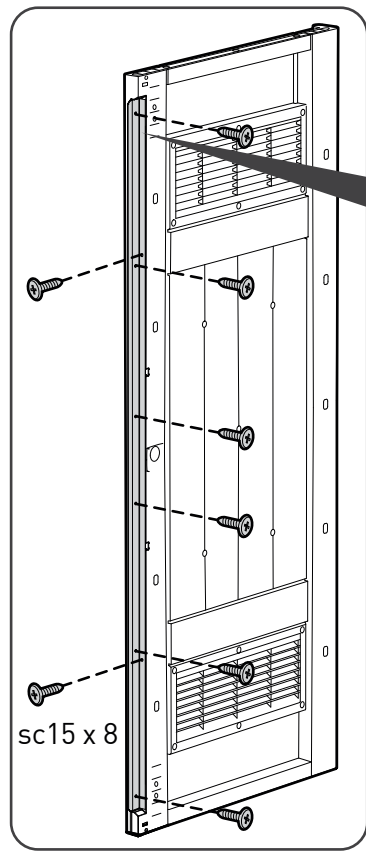

sc15 x 8

MOFMS

83

Wypoziomuj drzwi dopiero po umieszczeniu domku narzędziowego w jego ostatecznym położeniu

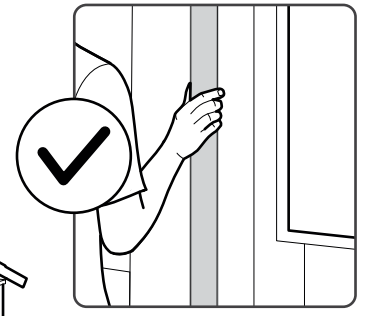
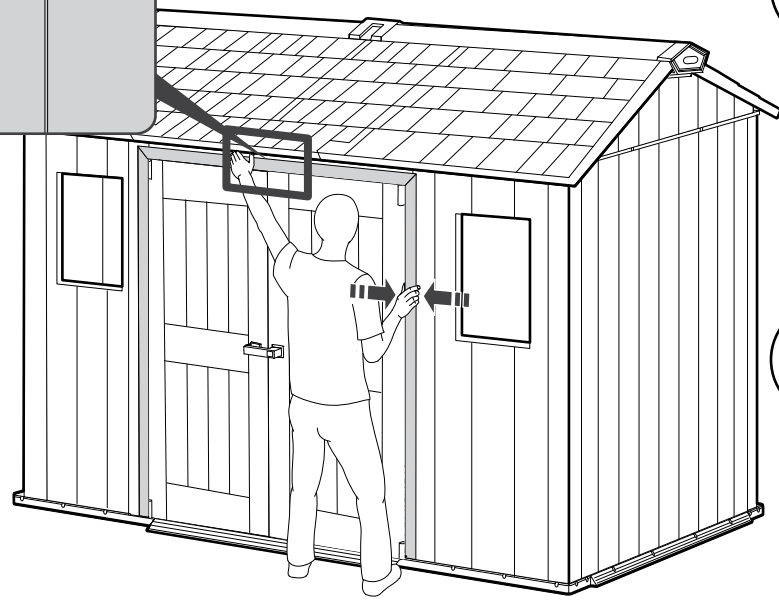
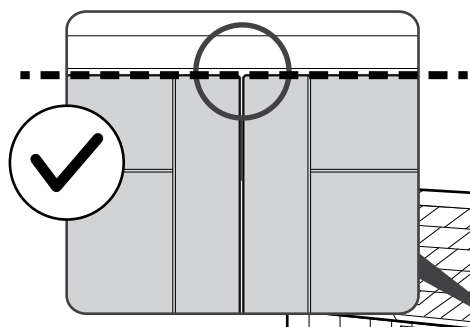

84



sc12 (x15)

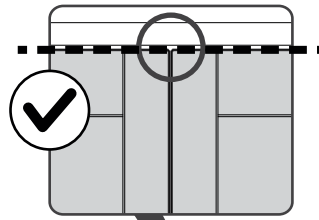
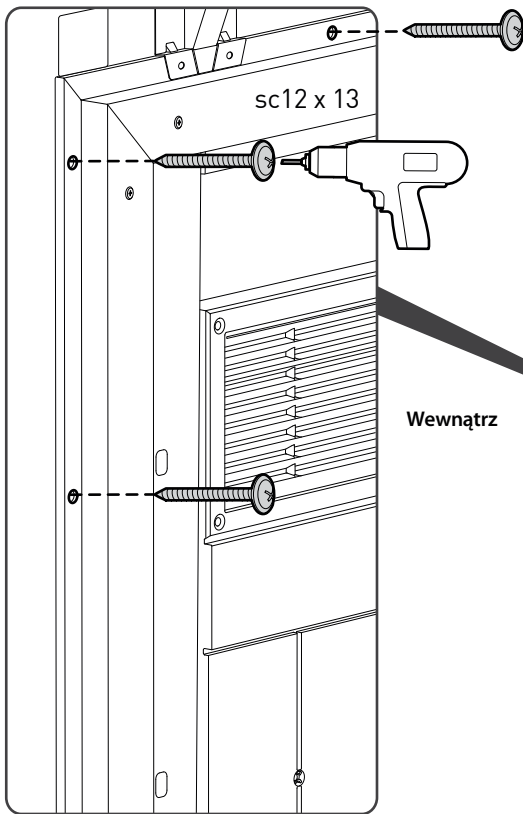
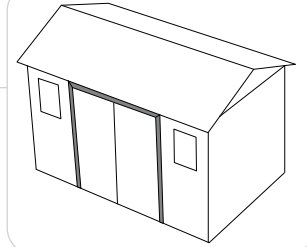

Wewnątrz

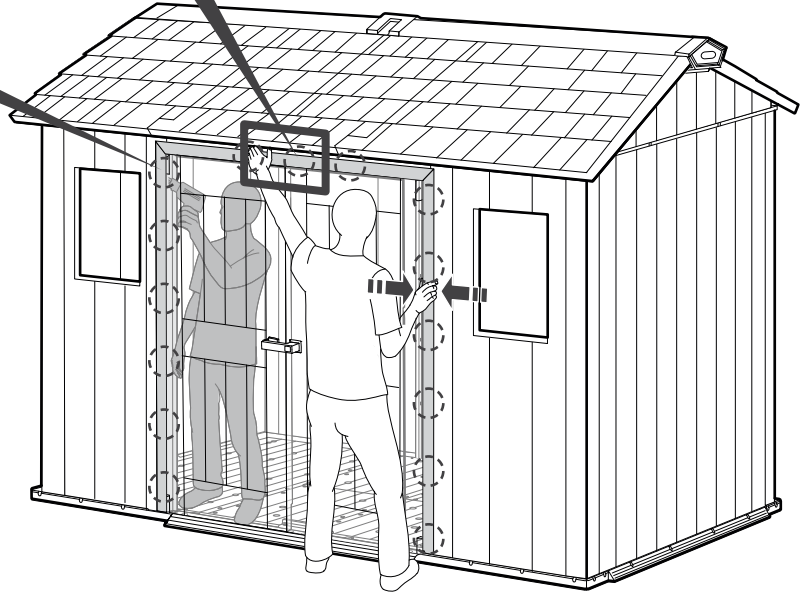

85

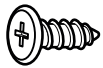

sc15 (x4)

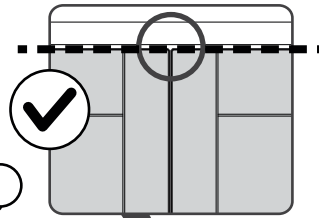
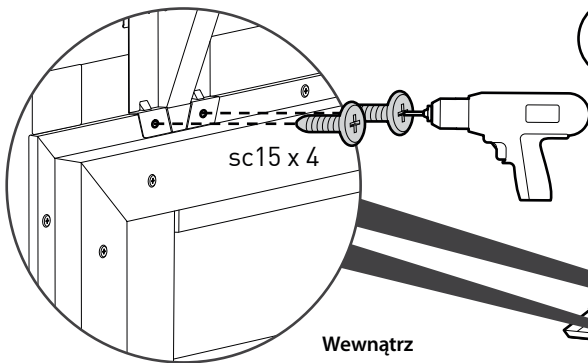
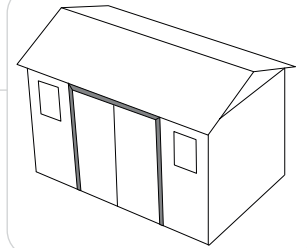

Wewnątrz

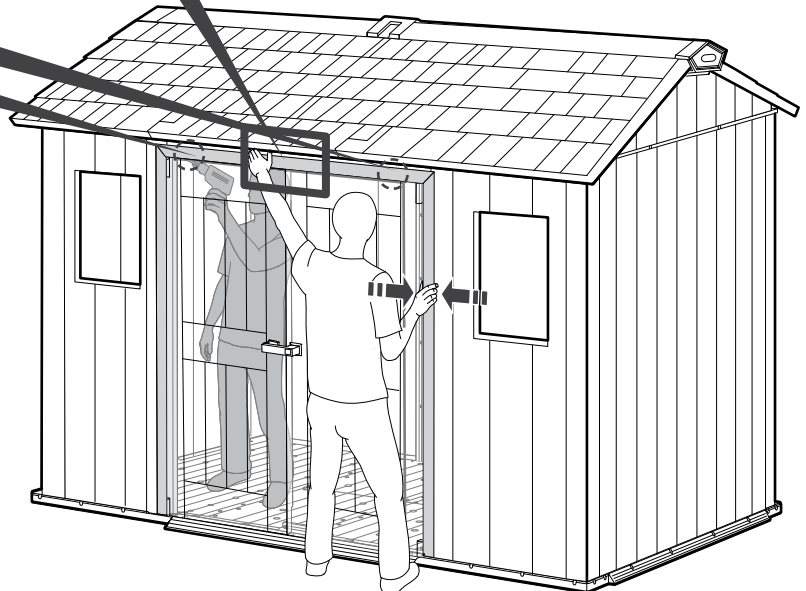

# MONTAŻ OKIEN

OPCJA

A

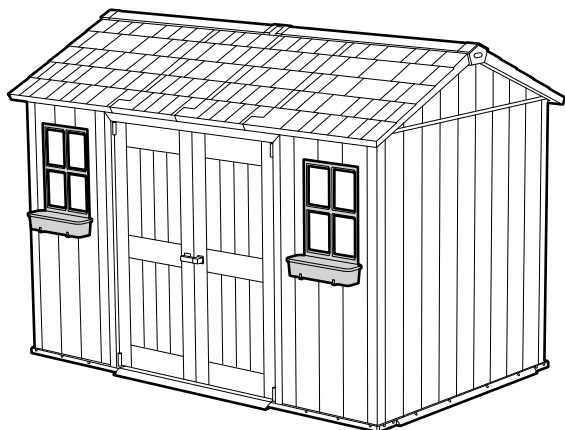

moP (x2)

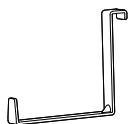

moMF (x4)

OPCJA

B

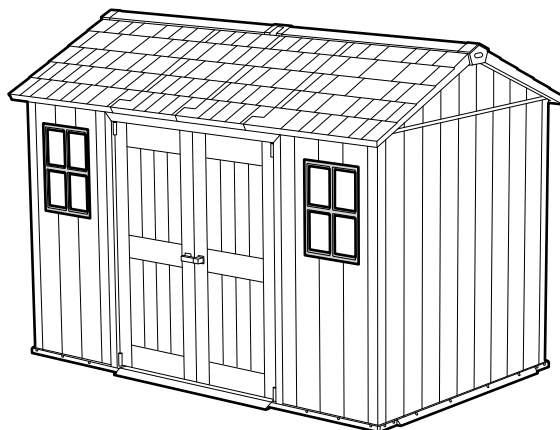

A



moMF (x4)

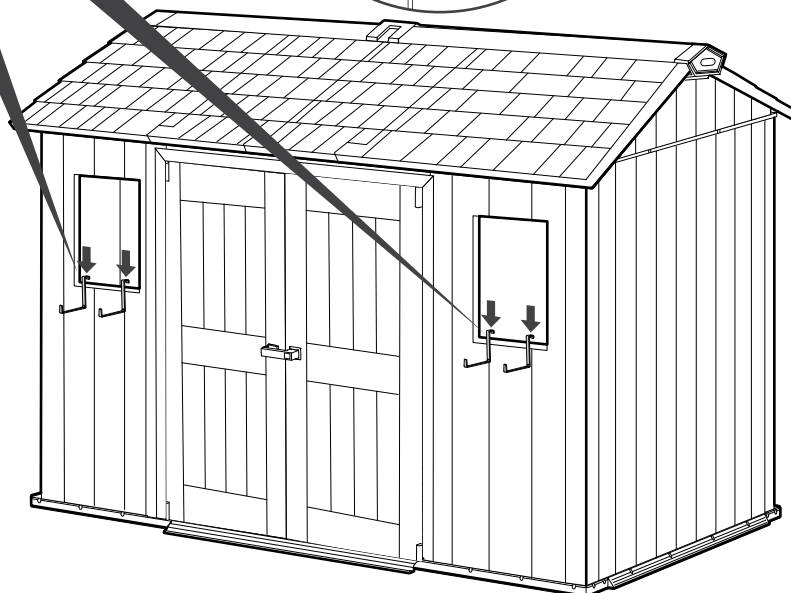
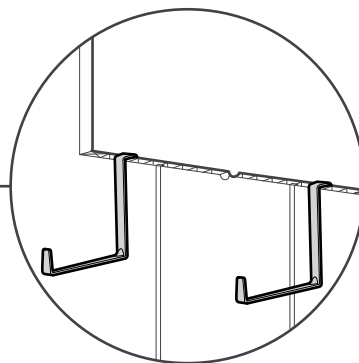
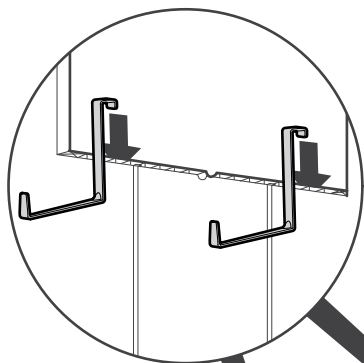
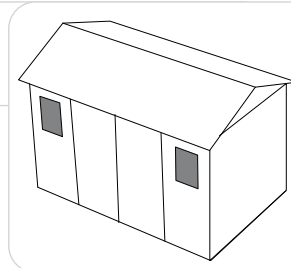

A + B



SMWF (x2)

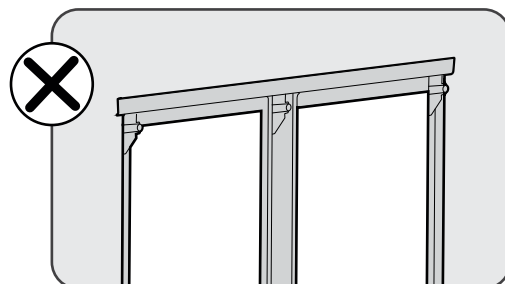
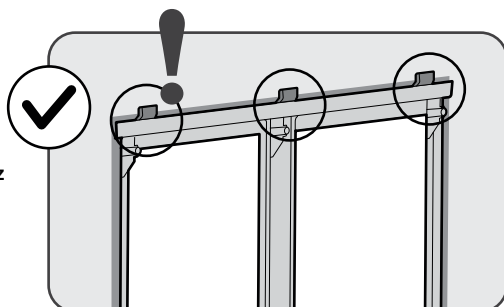
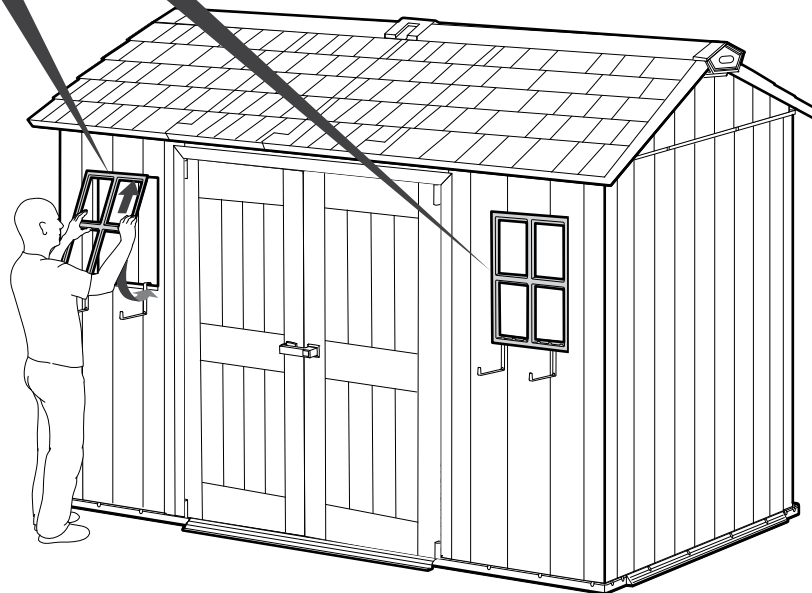
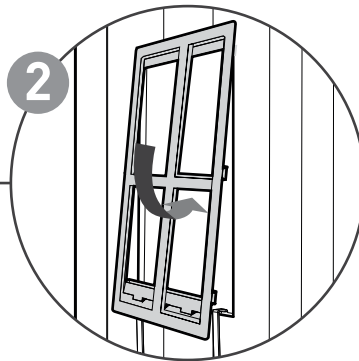
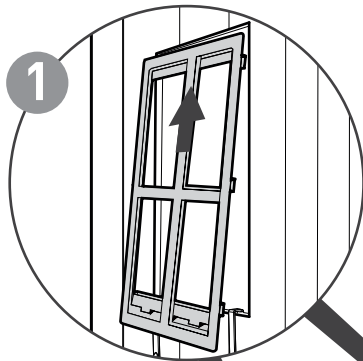
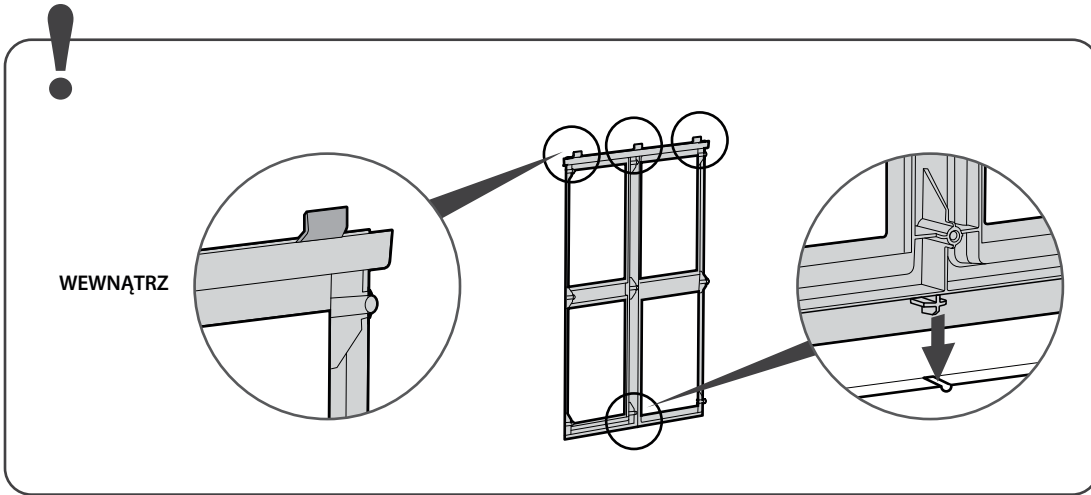
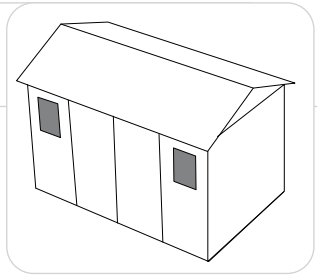

A + B



SMWG (x4)



MoWB (x2)



sc15 (x18)

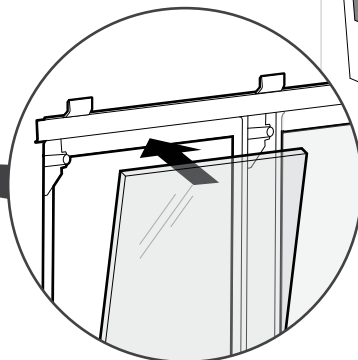
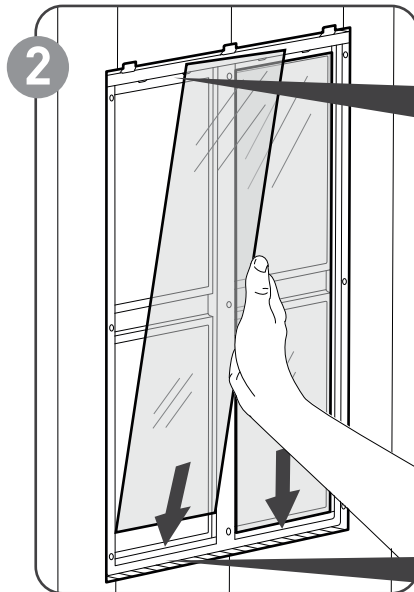
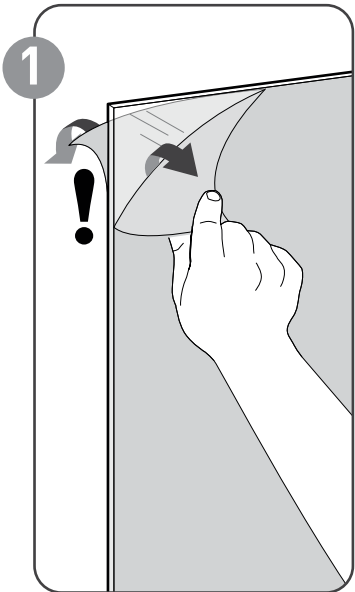
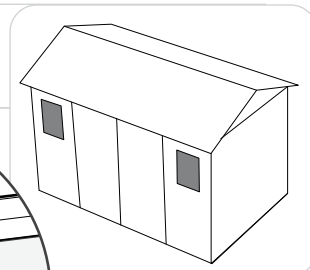

Wewnątrz

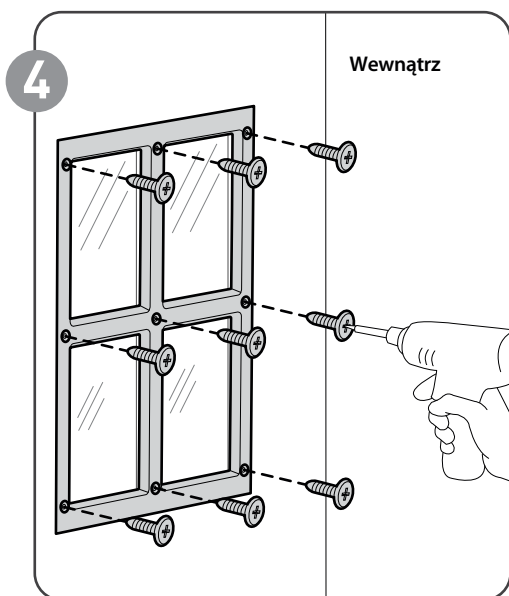
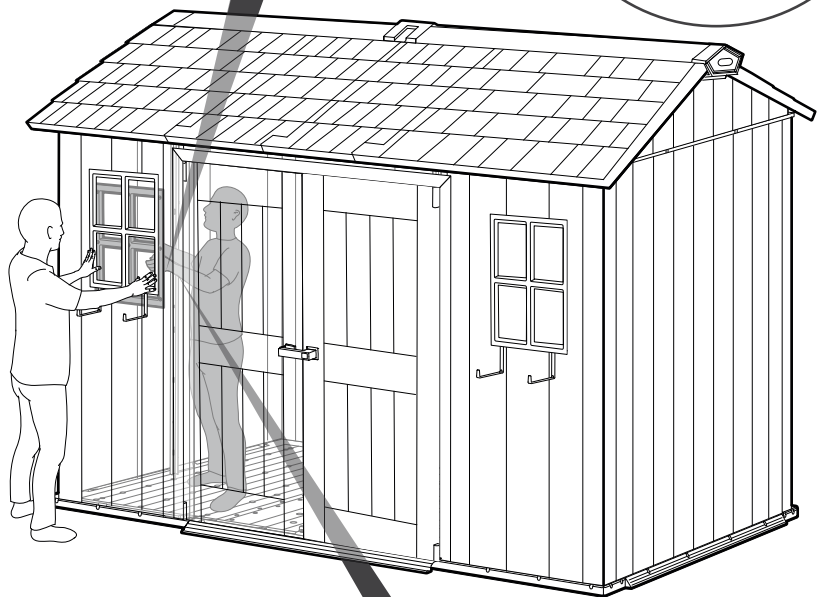
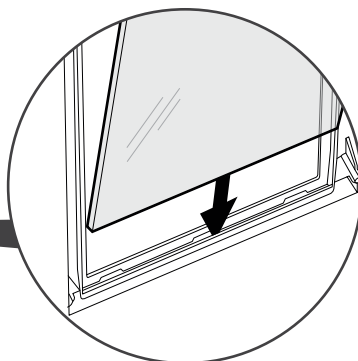

A



mOP (x2)

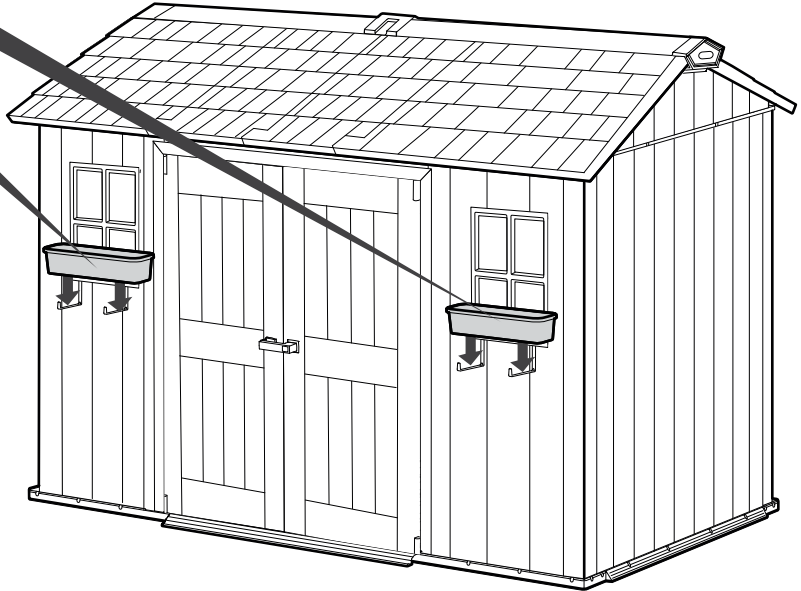
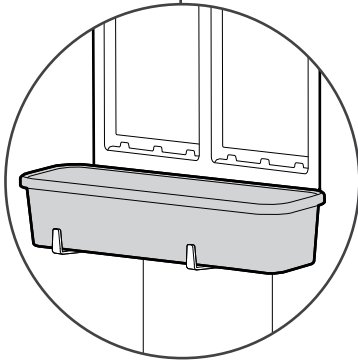
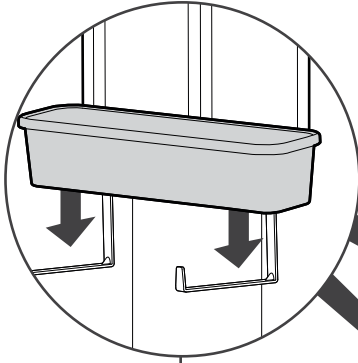
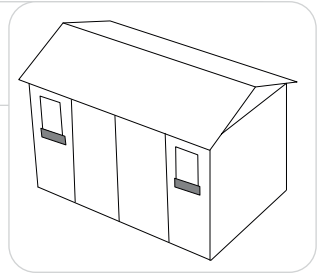

## KONSERWACJA



Ten domek nie wymaga konserwacji. Malowanie lub lakierowanie nie jest potrzebne.



Unikalna technologia, w której wykonany jest domek, pozwala na pomalowanie go na dowolny kolor. Schowka można używać w oryginalnym kolorze lub może on zostać pomalowany tak, aby dopasować się do otoczenia. Przed pomalowaniem prosimy o zapoznanie się ze szczegółową instrukcją pielęgnacji i konserwacji. Rodzaj farby: Ściany mogą zostać pomalowane wodną farbą akrylową do użytku zewnętrznego. Polecamy: czyste, jasne odcienie, wykończenie satynowe lub półpołysk. Podczas wyboru farby skonsultuj się ze swoim konsultantem ds. kolorów lub specjalistą od farb. Zastosowanie: Użyć wataki, aby nałożyć farbę na suchą powierzchnię ścian. Nie malować szczelin przypominających belki, znajdujących się w ścianach. Nie malować dachu, podłogi, łączeń ścian lub innych nieuszczelnionych części. Proszę pamiętać: malowanie wymaga konserwacji. Po pewnym czasie może być wymagane ponowne malowanie. W celu zachowania bezpieczeństwa – przed użyciem farby należy upewnić się, że postępujecie Państwo zgodnie ze wskazówkami dotyczącymi zachowania ostrożności i bezpieczeństwa.

## OPCJE

### MOCOWANIE DOMKU NARZĘDZIOWEGO DO PODŁOŻA

Przymocuj domek narzędziowy do fundamentu, w tym celu wywierć otwory w podłożu we wcześniej zaznaczonych miejscach i przykręcając ją do fundamentu za pomocą odpowiednich śrub (śruby nie wchodzi w skład zestawu).

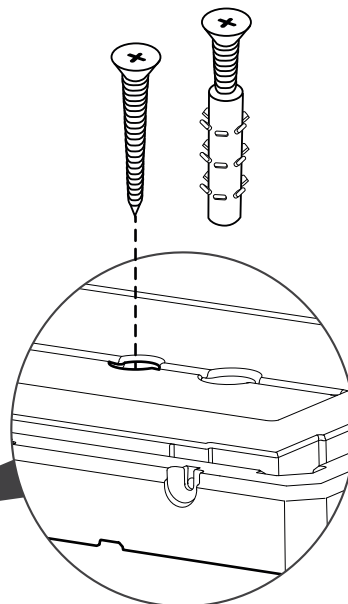
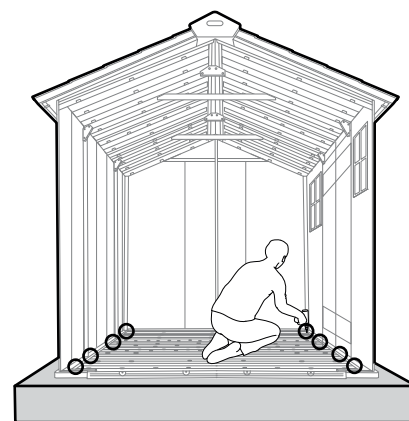
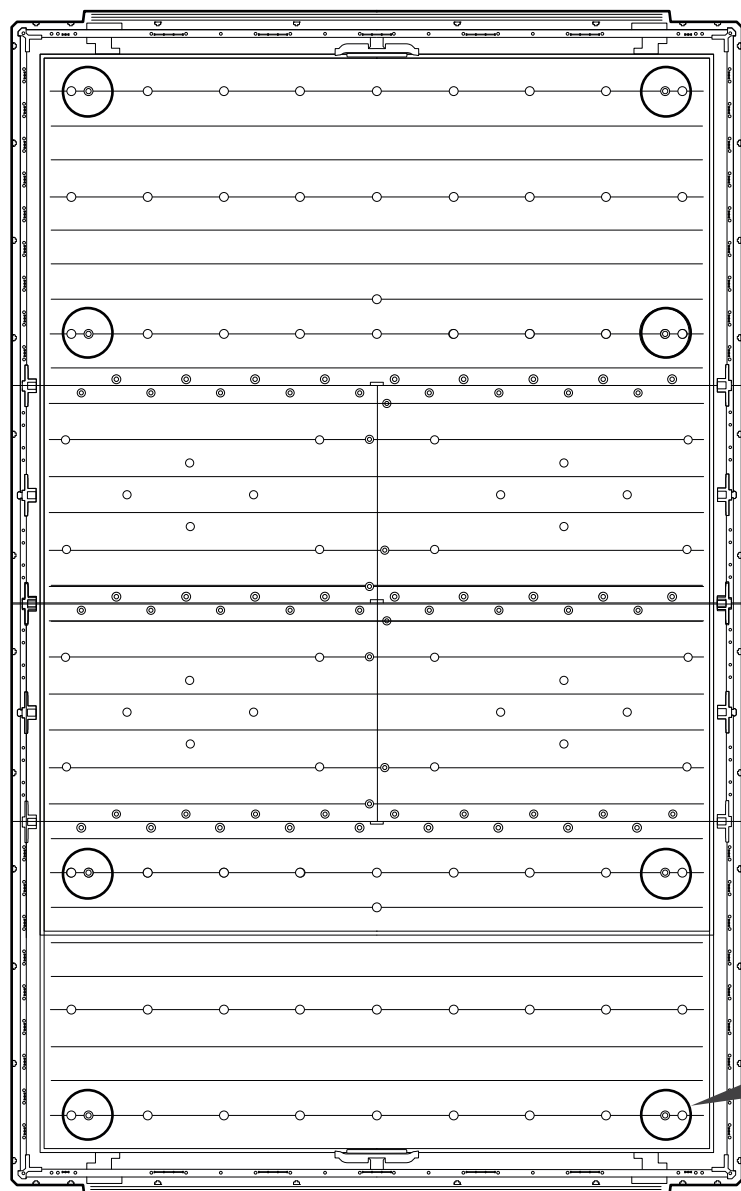



---

## ZASADY BEZPIECZNEGO UŻYTKOWANIA

---

- Domek narzędziowy przeznaczony jest wyłącznie do przechowywania rzeczy. Nie jest przeznaczony do zamieszkania.
- Zaleca się zabezpieczenie domku narzędziowego poprzez przymocowanie konstrukcji do obiektów stałych lub przykręcenie go do podłoża w wyznaczonych w podłodze punktach, za pomocą odpowiednich śrub (brak śrub w zestawie).
- Nie wykonywać montażu przy silnym wietrze oraz w niskich temperaturach.
- Należy systematycznie sprawdzać stabilność domku oraz poziom gruntu, na którym jest on ustawiony.
- Należy uważać na metalowe krawędzie elementów domku narzędziowego.
- Podczas montażu lub w trakcie użytkowania należy używać tylko narzędzi wyszczególnionych w instrukcji obsługi.
- Przy montażu i konserwacji domku narzędziowego zawsze należy nosić rękawice robocze, okulary ochronne i długie rękawy.
- Należy unikać używania kosiarek lub kos mechanicznych w pobliżu domku narzędziowego.
- W trakcie używania narzędzi elektrycznych zawsze należy nosić okulary ochronne i postępować zgodnie z instrukcjami producenta.
- Domek narzędziowy należy myć przy użyciu węża ogrodowego lub łagodnych detergentów. Nie należy używać twardych szczotek lub silnych środków czystości, w tym odtłuszczaczy lub produktów na bazie oleju lub acetonu. Produkty te mogą trwale uszkodzić powierzchnię domku narzędziowego.
- Nie należy przechowywać w domku narzędziowym gorących przedmiotów takich jak rozgrzane grille, lutownice oraz jakichkolwiek lotnych substancji chemicznych.
- Należy unikać opierania ciężkich przedmiotów o ściany domku, ponieważ może to spowodować odkształcenia.
- Dach domku narzędziowego powinien być regularnie oczyszczany z nagromadzonego śniegu bądź liści. Duże ilości śniegu na dachu mogą uszkodzić domek narzędziowy i być niebezpieczne dla użytkowników domku.
- Ważnym czynnikiem przy określaniu lokalizacji dla domku narzędziowego jest siła i kierunek wiatru. Należy starać się, aby oddziaływanie wiatru na domek narzędziowy było stosunkowo małe, szczególnie od strony drzwi. Aby zapobiec uszkodzeniom wynikającym z oddziaływania wiatru – drzwi domku powinny być zawsze zamknięte, kiedy nie jest on używany.
- Nie stawiać na dachu.
- Przed ustawieniem domku należy skonsultować się z lokalnymi urzędami, aby sprawdzić, czy nie są wymagane pozwolenia budowlane na postawienie domku narzędziowego.

---

## OGRANICZONA GWARANCJA DOŻYWOTNIA

---

Domek narzędziowy Keter ("Produkt") wykonano z wysokiej jakości surowców wtórnych pod ścisłą kontrolą i nadzorem. W przypadku problemów z Produktem, reklamacje proszę zgłaszać do działu obsługi klienta firmy Keter na naszej stronie internetowej ([www.keter.com](http://www.keter.com)) lub telefonicznie. Niniejsza gwarancja obejmuje wady wykonania lub wady materiałowe i obowiązuje na czas nieokreślony od dnia pierwotnego zakupu detalicznego. (Przez „wady” rozumie się niedoskonałości przeszkadzające w użytkowaniu Produktu). W takim przypadku, konsument zezwoli firmie Keter lub reprezentującej ją osobie sprawdzić i/lub przetestować rzekomo wadliwy produkt w laboratorium Keter lub w dowolnym innym miejscu wybranym według wyłącznego uznania firmy Keter. Niniejsza gwarancja nie obejmuje defektów powstałych w wyniku zwykłej eksploatacji, w tym między innymi rys, zadrapań lub pęknięć powstałych w trakcie użytkowania produktu, odbarwień lub wyblaknięcia kolorów, rdzewienia, skutków niewłaściwego użytkowania, nadużyć, zaniedbań, modyfikacji, malowania, przesuwania, transportu lub przemieszczania Produktu, działania „siły wyższej”, w tym między innymi opadów gradu, burzy, zalania i pożaru, a także szkód wynikowych lub następczych. Montaż i obchodzenie się z produktem w sposób niezgodny z zaleceniami, wytycznymi i ograniczeniami określonymi w instrukcji użytkowania Produktu, a także jego zastosowanie do celów komercyjnych lub publicznych, unieważniają niniejszą gwarancję. Firma Keter nie ponosi odpowiedzialności za żadne szkody poniesione przez konsumenta i/lub osoby trzecie lub za uszkodzenie bądź utratę przedmiotów znajdujących się wewnątrz lub w pobliżu domku ogrodowego. Po przedstawieniu dowodu zakupu i dowodów wadliwości reklamowanego produktu, z zastrzeżeniem terminowego zgłoszenia reklamacji, Keter, według własnego uznania, wymieni wadliwe części Produktu lub zwróci proporcjonalną część ceny zakupu obliczoną metodą amortyzacji liniowej, zakładając roczną amortyzację w wysokości 10% i zachowanie 10% przez cały okres gwarancji.

